

**This project is to be a staged building consent.**  
**Stage 1 - All below ground work, drainage, piling, retaining, footings and concrete slabs on ground.**  
**Stage 2 - Remainder of Project**

NOTE:  
 Refer Chester Consultants plans #12049  
 for all Fire Report Details

NOTE:  
 Refer KOA plans #116292 for all  
 structural engineering, concrete, beam  
 sizing, bracing, footing & piling sizes &  
 details.

**LEGAL DESCRIPTION**  
 81 SARSFIELD STREET, HERNE BAY  
 Lot 1 D.P. 375454  
 SITE AREA: 916m<sup>2</sup>  
 Zone - Mixed Housing Urban

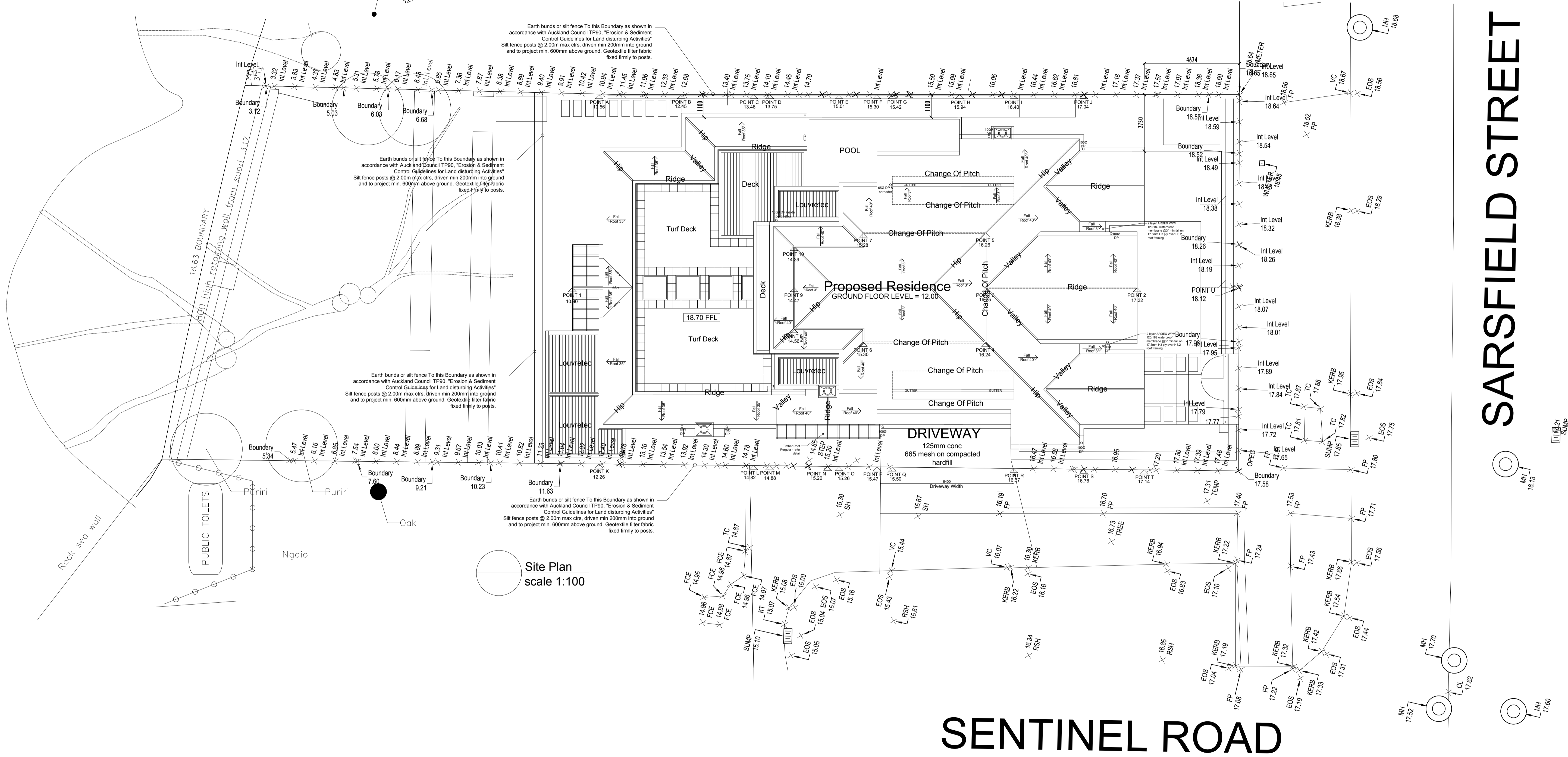

Site Plan  
 scale 1:100

**Building to be set-out and accurately positioned on site by a licenced cadastral surveyor prior to piling & slab placement & re-checked at roof framing stage**

**RESOURCE CONSENT - R/LUC/2017/1200**  
 Refer Resource Consent for 81 Sarsfield Street

**PLUMBING & DRAINAGE**  
 Refer Plumbing & Drainage plans

Revisions	General notes

NOTE:  
**AMENDMENT**  
**09/18**

59 ROSEBERRY AVE. BIRKENHEAD AUCKLAND TEL (09)418 2432 FAX (09)419 5142  
 APARTMENT DEVELOPMENT  
 81 SARSFIELD STREET, HERNE BAY

**DELAMARE ARCHITECTS**

Date: DEC'17  
 Scale: 1/100 @ A1  
 Drawing Reference: SAR 001  
 Clad ref: SAR  
 CADREF

USE FIGURED DIMENSIONS. DO NOT SCALE FROM DRAWING.  
 ALL LEVELS AND DIMENSIONS TO BE CHECKED ON SITE.  
 DRAWING TO BE READ IN CONJUNCTION WITH ALL RELEVANT DOCUMENTS.  
 © THE COPYRIGHT OF THIS DRAWING IS THE PROPERTY OF DAVID DELAMARE

**SARSFIELD STREET**

**SENTINEL ROAD**

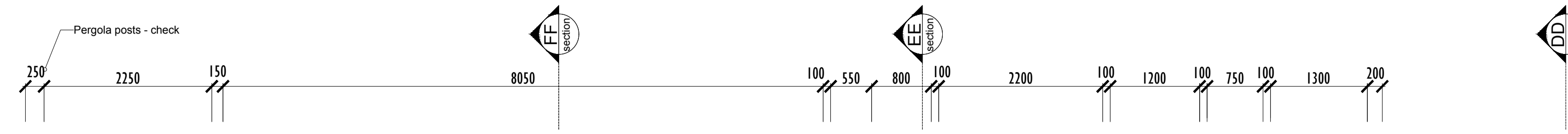

NOTE:  
Refer Chester Consultants plans #12049  
for all Fire Report Details

NOTE:  
Refer KOA plans #116292 for all  
structural engineering, concrete, beam  
sizing, bracing, footing & piling sizes &  
details.

**This project is to be a staged building consent.**  
**Stage 1 - All below ground work, drainage, piling,  
 retaining, footings and concrete slabs on  
 ground.**  
**Stage 2 - Remainder of Project**

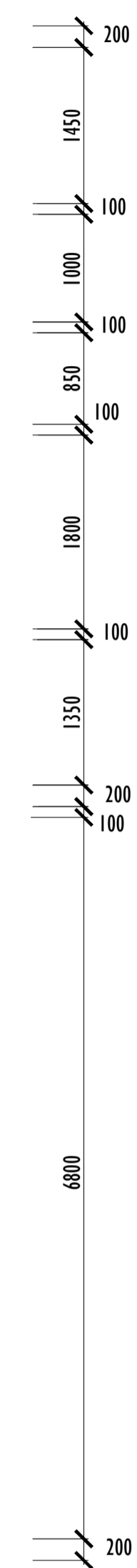
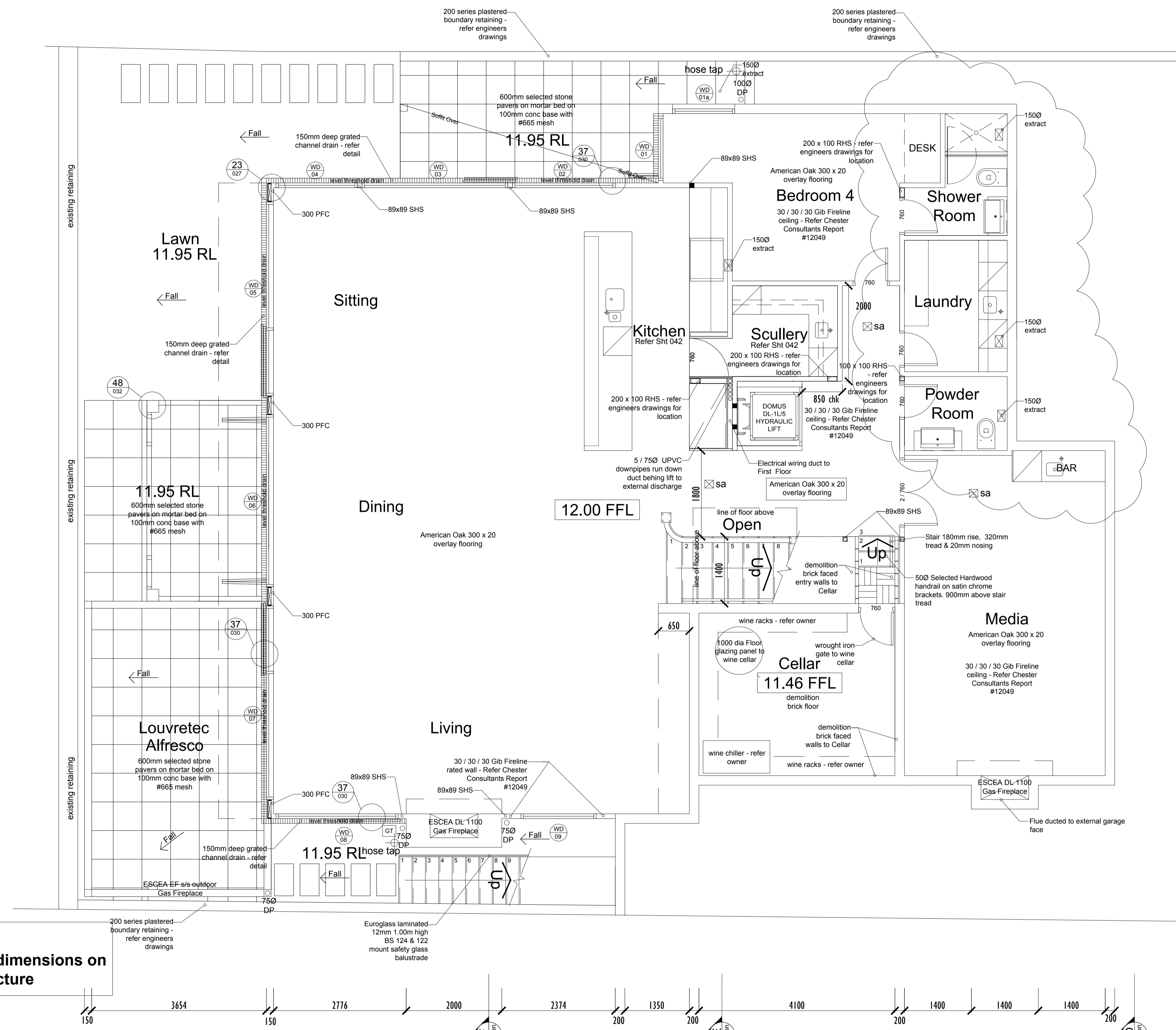

**IMPORTANT**  
 Confirm all Joinery dimensions on  
 site prior to manufacture

KEY  
 sa smoke alarm

Ground Floor Plan  
 scale 1:50

NOTE:  
 1. All floor, wall & roof framing shall be  
 H3.2 SG 8 dry framing timber

- NOTES
- All work to comply with NZBC 2004 and NZS 3604 2011
  - All external walls framed with ex 90 x 45 H3.2 @600 CTRS., all internal walls ex 90 x 45 H3.2 @600 CTRS.
  - All beams in joist line
  - All exposed joists treated H3.2
  - All internal rafters H3.2
  - All floor fixings as per table 7.5 NZS 3604 2011 - Bottom plate to slab - M12 @ 600ctrs.
  - All roof fixings as per table 10.14 NZS 3604 2011 - REFER FRAMING PLAN NOTES
  - All exterior structural steel HD galvanised. All exterior fixings stainless steel.
  - Install R2.6 Batts insulation to all exterior walls  
Install R3.6 Batts insulation to all areas of roof
  - Cavity Battens fixed structurally using 75x3.15mm JH nails @300ctrs staggered  
Weatherboards fixed using 75x3.25mm JH nails, single fixing 10mm above top of lower board.

Revisions	General notes

NOTE:  
**AMENDMENT**  
**09/18**

59 ROSEBERRY AVE, BIRKENHEAD, AUCKLAND. TEL (09)418 2432 FAX (09)419 5142  
 APARTMENT DEVELOPMENT  
 81 SANSFIELD STREET, HERNE BAY

**DELAMARE ARCHITECTS**

Drawing Reference: SAR 002  
 Date: DEC'17  
 Scale: 1/50 @ A1  
 Cid ref: SAR  
 CADREF

USE FIGURED DIMENSIONS. DO NOT SCALE FROM DRAWING. ALL LEVELS AND DIMENSIONS TO BE CHECKED ON SITE. DRAWING TO BE READ IN CONJUNCTION WITH ALL RELEVANT DOCUMENTS. © THE COPYRIGHT OF THIS DRAWING IS THE PROPERTY OF DAVID DELAMARE.

**IMPORTANT**  
Confirm all Joinery dimensions on site prior to manufacture

NOTE:  
Refer Chester Consultants plans #12049 for all Fire Report Details

NOTE:  
Refer KOA plans #116292 for all structural engineering, concrete, beam sizing, bracing, footing & piling sizes & details.

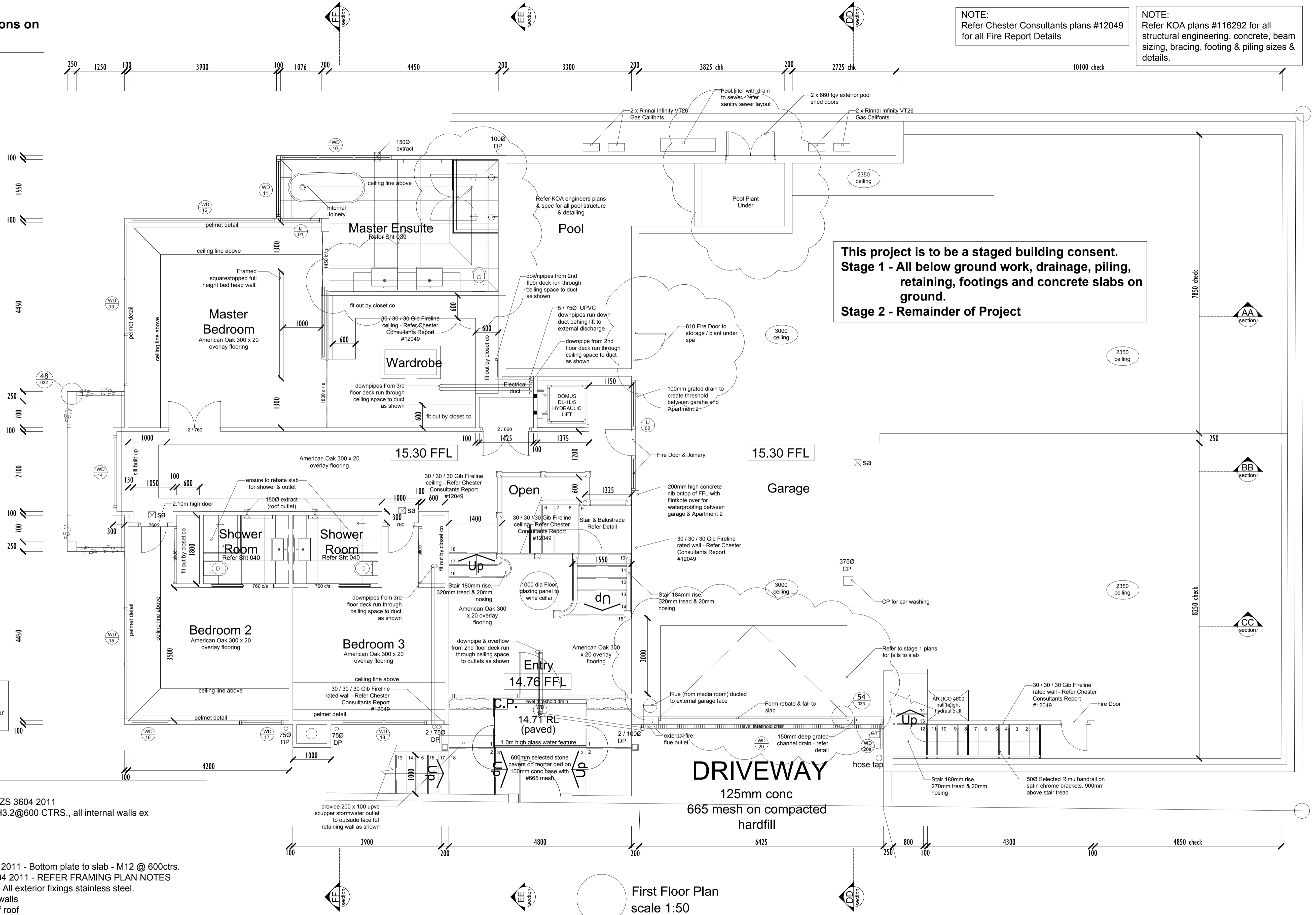

**Key - Smoke Alarm**  
sa smoke alarm  
smoke alarms to be hardwired with backup battery power and wireless communication between all units

NOTE:  
1. All floor, wall & roof framing shall be H3.2 SG 8 dry framing timber

- NOTES
1. All work to comply with NZBC 2004 and NZS 3604 2011
  2. All external walls framed with ex 90 x 45 H3.2@600 CTRS., all internal walls ex 90 x 45 H3.2. @600 CTRS.
  3. All beams in joist line
  4. All exposed joists treated H3.2
  5. All internal rafters H3.2
  6. All floor fixings as per table 7.5 NZS 3604 2011 - Bottom plate to slab - M12 @ 600ctrs.
  7. All roof fixings as per table 10.14 NZS 3604 2011 - REFER FRAMING PLAN NOTES
  8. All exterior structural steel HD galvanised. All exterior fixings stainless steel.
  9. Install R2.6 Batts insulation to all exterior walls  
Install R3.6 Batts insulation to all areas of roof
  10. Cavity Battens fixed structurally using 75x3.15mm JH nails @300ctrs staggered  
Weatherboards fixed using 75x3.25mm JH nails, single fixing 10mm above top of lower board.

Revisions	General notes

Revisions	General notes

NOTE:

**AMENDMENT**  
**09/18**

59 ROSEBERRY AVE BIRKENHEAD AUCKLAND TEL (09)418 2432 FAX (09)419 5142  
APARTMENT DEVELOPMENT  
81 SANSFIELD STREET, HERNE BAY

**DELAMARE**  
**ARCHITECTS**

First Floor Plan  
Drawing Reference SAR 003

Date DEC'17  
Scale 1/50 @ A1  
Cad ref SAR  
CADREF

USE FIGURED DIMENSIONS DO NOT SCALE FROM DRAWING.  
ALL LEVELS AND DIMENSIONS TO BE CHECKED ON SITE.  
DRAWING TO BE READ IN CONJUNCTION WITH ALL RELEVANT DOCUMENTS.  
© THE COPYRIGHT OF THIS DRAWING IS THE PROPERTY OF DAVID DELAMARE

- NOTES**
- All work to comply with NZBC 2004 and NZS 3604 2011
  - All external walls framed with ex 90 x 45 H3.2 @600 CTRS., all internal walls ex 90 x 45 H3.2 @600 CTRS.
  - All beams in joist line
  - All exposed joists treated H3.2
  - All internal rafters H3.2
  - All floor fixings as per table 7.5 NZS 3604 2011 - Bottom plate to slab - M12 @ 600ctrs.
  - All roof fixings as per table 10.14 NZS 3604 2011 - REFER FRAMING PLAN NOTES
  - All exterior structural steel HD galvanised. All exterior fixings stainless steel.
  - Install R3.6 Batts insulation to all exterior walls
  - Install R3.6 Batts insulation to all areas of roof
  - Cavity Battens fixed structurally using 75x3.15mm JH nails @300ctrs staggered
  - Weatherboards fixed using 75x3.25mm JH nails, single fixing 10mm above top of lower board.

**NOTE:**  
1. All floor, wall & roof framing shall be H3.2 SG 8 dry framing timber

**Key - Smoke Alarm**  
sa smoke alarm  
smoke alarms to be hardwired with backup battery power and wireless communication between all units

**NOTE:**  
Refer Chester Consultants plans #12049 for all Fire Report Details

**NOTE:**  
Refer KOA plans #116292 for all structural engineering, concrete, beam sizing, bracing, footing & piling sizes & details.

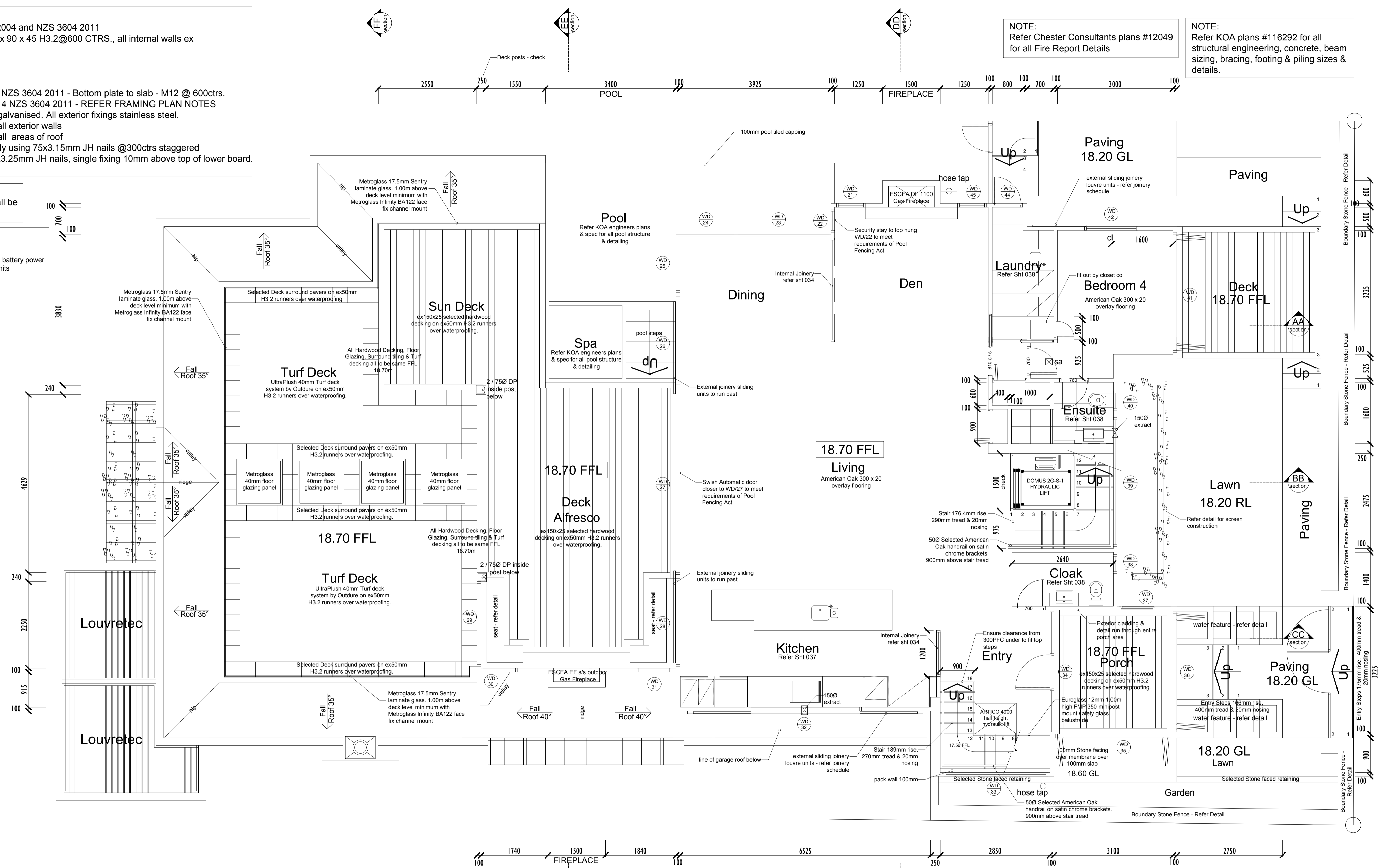

**IMPORTANT**  
Confirm all Joinery dimensions on site prior to manufacture

Second Floor Plan  
scale 1:50

Revisions	General notes

**AMENDMENT**  
09/18

59 ROSEBERRY AVE. BIRKENHEAD AUCKLAND TEL (09)418 2432 FAX (09)419 5142  
**APARTMENT DEVELOPMENT**  
 81 SANSFIELD STREET, HERNE BAY

**DELAMARE ARCHITECTS**

DATE: DEC'17  
 SCALE: 1/50 @ A1  
 DRAWING REFERENCE: SAR 004 B  
 CADD REF: SAR  
 CAD REF: SAR

USE FIGURED DIMENSIONS. DO NOT SCALE FROM DRAWING. ALL LEVELS AND DIMENSIONS TO BE CHECKED ON SITE. DRAWING TO BE READ IN CONJUNCTION WITH ALL RELEVANT DOCUMENTS. © THE COPYRIGHT OF THIS DRAWING IS THE PROPERTY OF DAVID DELAMARE

**NOTES**

- All work to comply with NZBC 2004 and NZS 3604 2011
- All external walls framed with ex 90 x 45 H3.2 @600 CTRS., all internal walls ex 90 x 45 H3.2 @600 CTRS.
- All beams in joist line
- All exposed joists treated H3.2
- All internal rafters H3.2
- All floor fixings as per table 7.5 NZS 3604 2011 - Bottom plate to slab - M12 @ 600ctrs.
- All roof fixings as per table 10.14 NZS 3604 2011 - REFER FRAMING PLAN NOTES
- All exterior structural steel HD galvanised. All exterior fixings stainless steel.
- Install R2.6 Batts insulation to all exterior walls  
Install R3.6 Batts insulation to all areas of roof
- Cavity Battens fixed structurally using 75x3.15mm JH nails @300ctrs staggered  
Weatherboards fixed using 75x3.25mm JH nails, single fixing 10mm above top of lower board.

**NOTE:**

- All floor, wall & roof framing shall be H3.2 SG 8 dry framing timber

**KEY**

sa smoke alarm

**NOTE:**

Refer Chester Consultants plans #12049 for all Fire Report Details

**NOTE:**

Refer KOA plans #116292 for all structural engineering, concrete, beam sizing, bracing, footing & piling sizes & details.

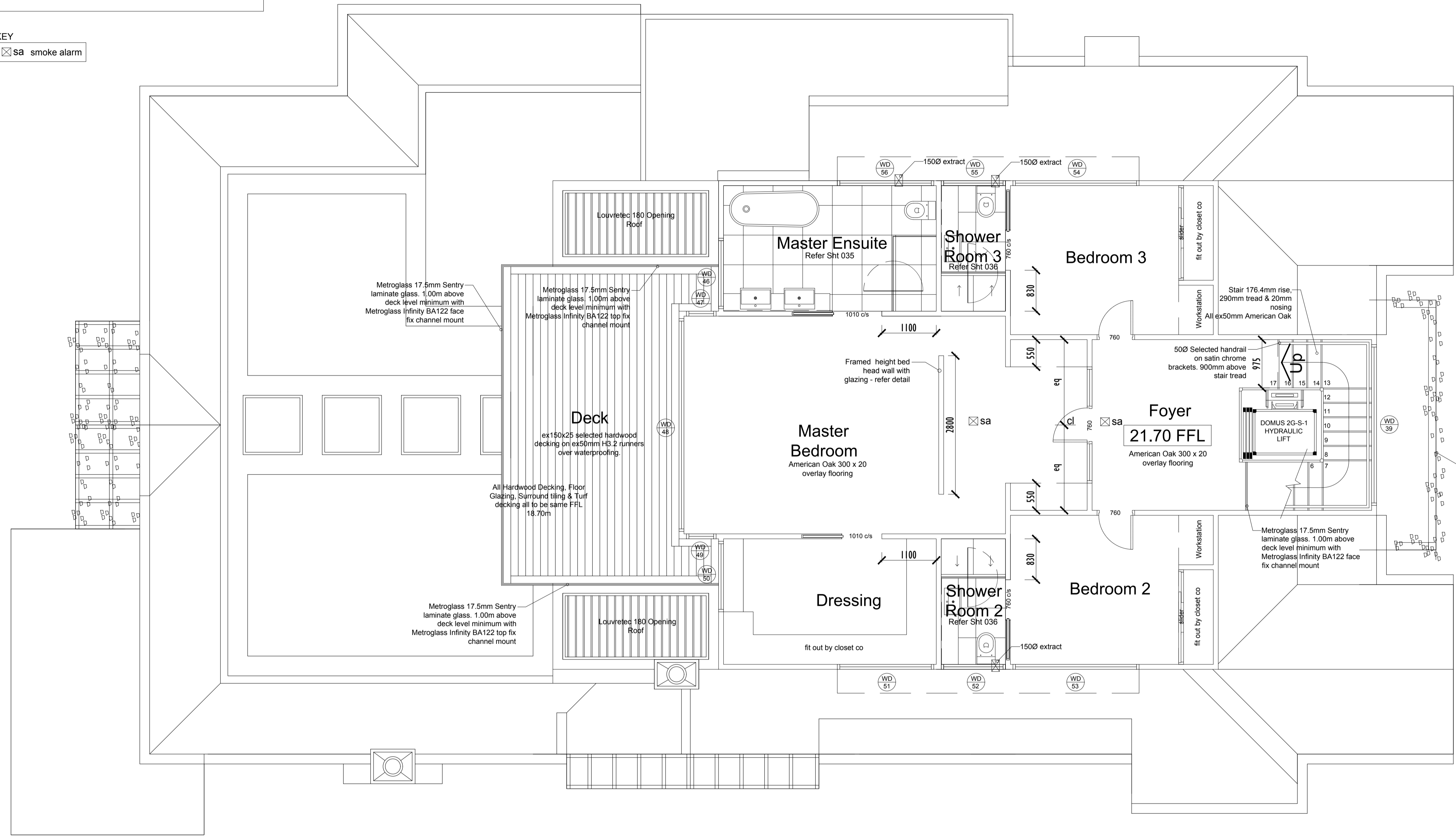
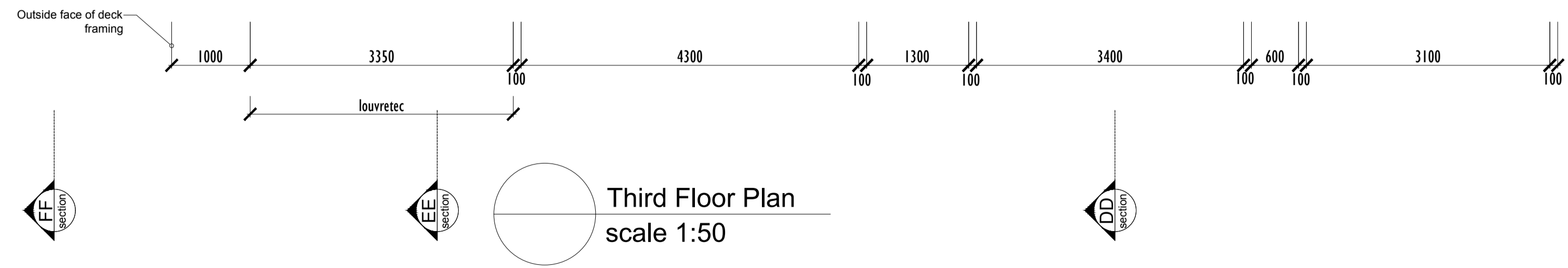
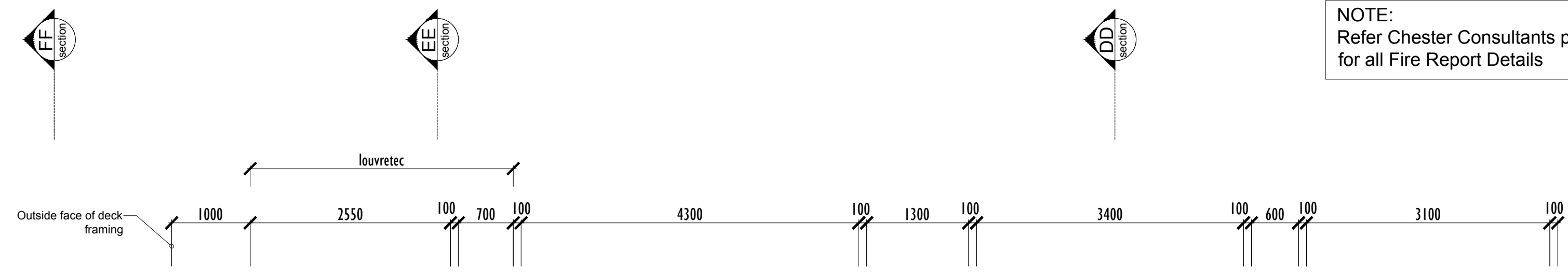
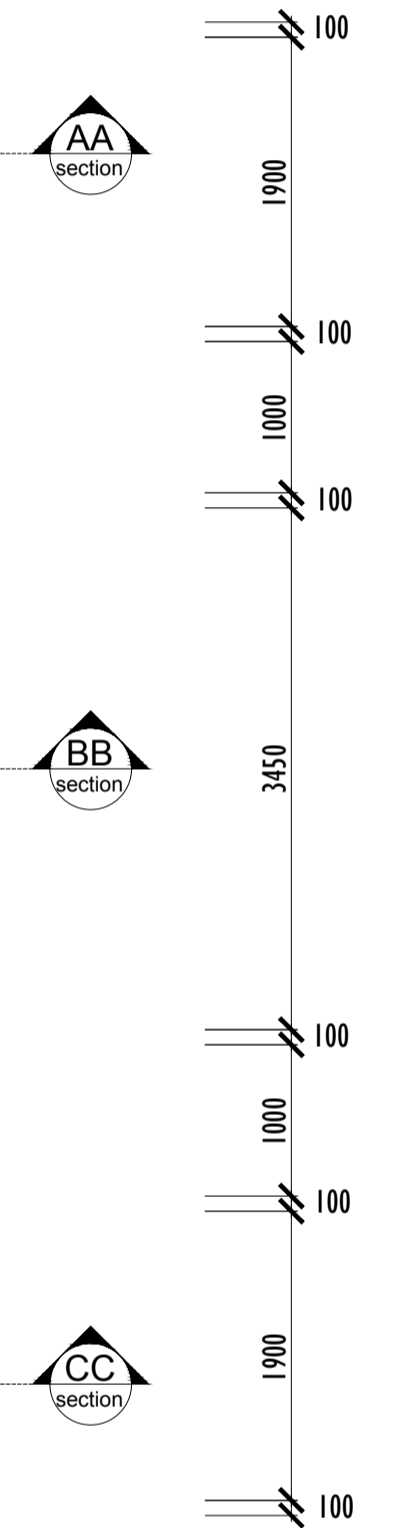
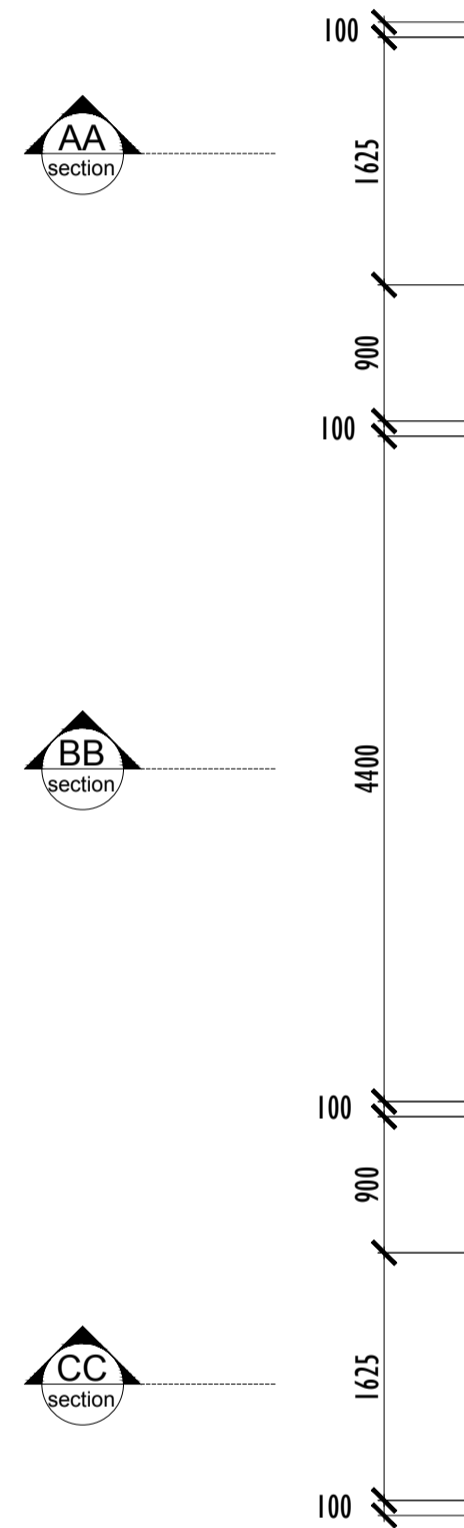

**IMPORTANT**  
Confirm all Joinery dimensions on site prior to manufacture

Third Floor Plan  
scale 1:50

Revisions	General notes

**AMENDMENT**  
**09/18**

59 ROSEBERRY AVE. BIRKENHEAD AUCKLAND TEL (09)418 2432 FAX (09)419 5142  
**APARTMENT DEVELOPMENT**  
 81 SARSFIELD STREET, HERNE BAY

**DELAMARE ARCHITECTS**

THIRD FLOOR PLAN  
 Drawing Reference: SAR 005  
 Date: DEC'17  
 Scale: 1/50 @ A1  
 Cad ref: SAR  
 CADREF

USE FIGURED DIMENSIONS. DO NOT SCALE FROM DRAWING. ALL LEVELS AND DIMENSIONS TO BE CHECKED ON SITE. DRAWING TO BE READ IN CONJUNCTION WITH ALL RELEVANT DOCUMENTS. ©THE COPYRIGHT OF THIS DRAWING IS THE PROPERTY OF DAVID DELAMARE

**NOTES : ROOFING**  
 Roof vents to Ardex 120 / 189 (2 layer) roofed areas.  
 2 x Vents to be placed per 20m2 of roofing area.  
 Roof Underlay: Thermakraft Covertek 405 self supporting roof underlay - does not require netting

**NOTES : Downpipes**  
 All upper roof downpipes to discharge into rainwater storage tanks under garage slab for potable water.  
 All Lower roof, roof garden & decks to connect directly into council approved stormwater discharge.

**NOTE:**  
 Refer Chester Consultants plans #12049 for all Fire Report Details

**NOTE:**  
 Refer KOA plans #116292 for all structural engineering, concrete, beam sizing, bracing, footing & piling sizes & details.

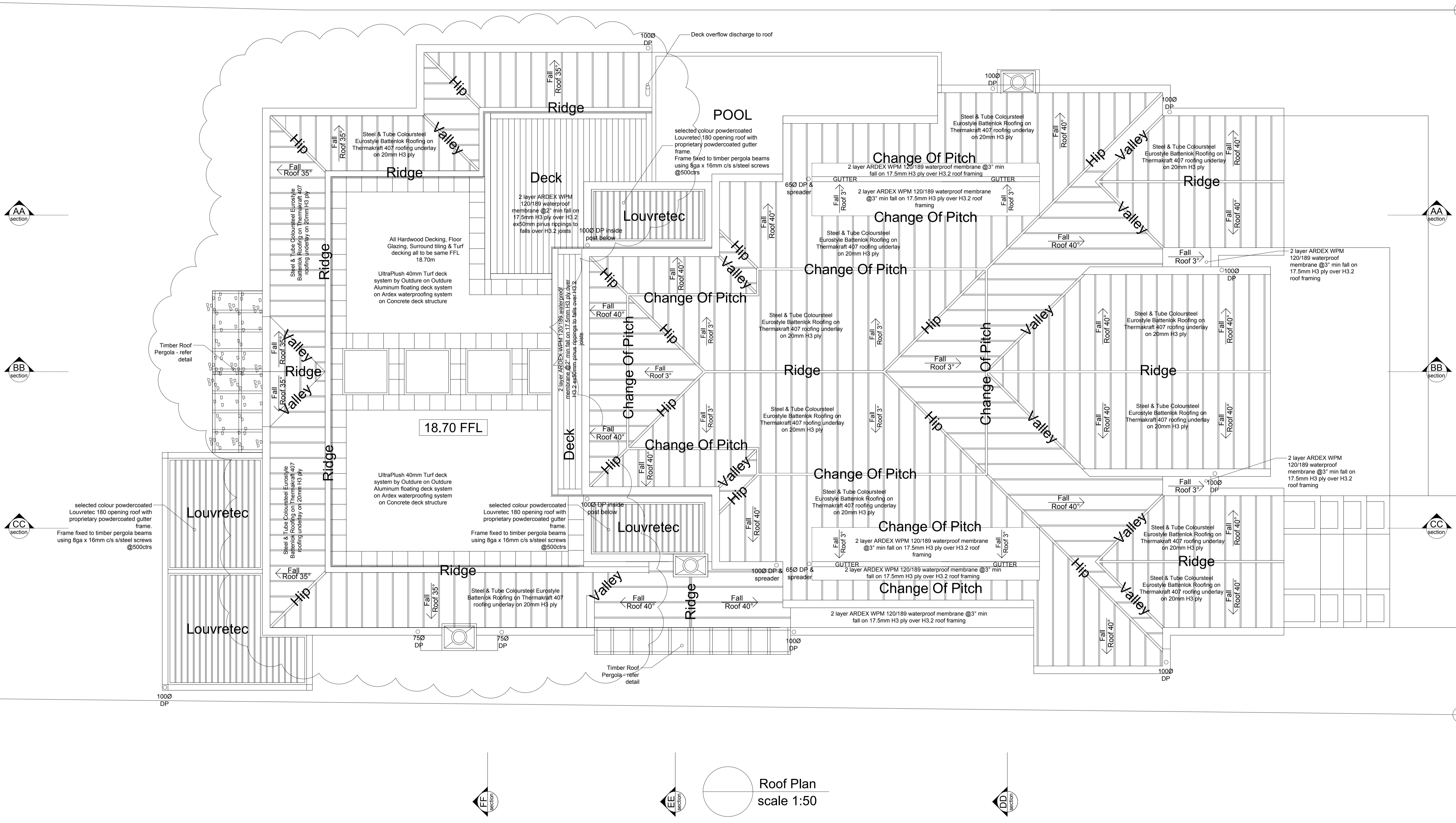

Roof Plan  
 scale 1:50

Revisions	General notes

**NOTE:**  
**AMENDMENT**  
**09/18**

59 ROSEBERRY AVE. BIRKENHEAD AUCKLAND TEL (09)418 2432 FAX (09)419 5142  
 APARTMENT DEVELOPMENT  
 81 SANSFIELD STREET, HERNE BAY

**DELAMARE ARCHITECTS**

Roof Plan  
 Drawing Reference: SAR 006  
 Date: DEC'17  
 Scale: 1/50 @ A1  
 Cad ref: SAR  
 CADREF

USE FIGURED DIMENSIONS. DO NOT SCALE FROM DRAWING. ALL LEVELS AND DIMENSIONS TO BE CHECKED ON SITE. DRAWING TO BE READ IN CONJUNCTION WITH ALL RELEVANT DOCUMENTS. © THE COPYRIGHT OF THIS DRAWING IS THE PROPERTY OF DAVID DELAMARE



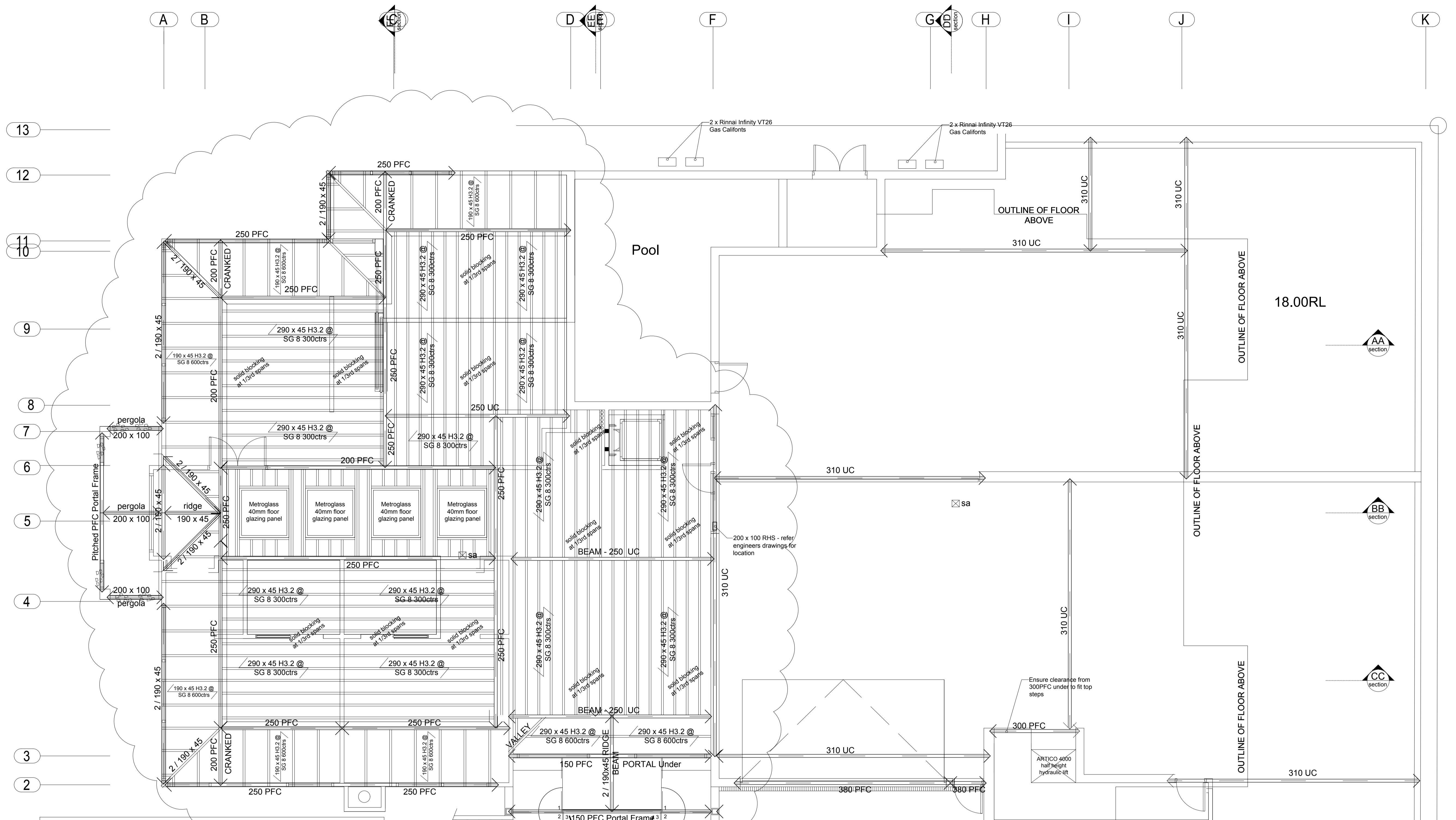

- NOTES : FRAMING**
1. Solid blocking to mid span of floor joists (same timber size as joists)
  2. Double joists under external load bearing walls (same timber size as joists)
  3. Holding down fixing sizes for Bottom plate internal walls - 4kN connection @900ctrs. external walls - 8kN connections @900ctrs.
  4. Top plate to stud fixing - 2/90 x 3.15 end nails & 2 wire dogs. Top Plate to rafter fixing 2/90 x 3.15 skew nails & strap fixing (4/30 x 3.15mm nails to both rafter & top plate). Purlin fixing 1/14g self-drilling type 17 screw, 100mm long
  5. Lintel Fixing - 25 x 1 strap with 6/30 x 25mm nails into both Lintel & stud. Lintels within 400mm of top plate 2 x 90 x 45 trimming studs. Lintels more than 400mm 3 x 90 x 45 trimming studs
  6. All Timber to be SG8 unless noted otherwise  
All Beam / Lintel Supports to be 2/90x45 Double Studs Posts U.N.O.

Revisions	General notes

NOTE:  
**AMENDMENT 09/18**

59 ROSEBERRY AVE. BIRKENHEAD AUCKLAND TEL (09)418 2432 FAX (09)419 5142  
**APARTMENT DEVELOPMENT**  
 81 SANSFIELD STREET, HERNE BAY

**DELAMARE ARCHITECTS**

SECOND FLOOR FRAMING Drawing Reference SAR 008 Date DEC'17 Scale 1/50 @ A1  
 Cid ref SAR  
 CADREF

USE FIGURED DIMENSIONS. DO NOT SCALE FROM DRAWING. ALL LEVELS AND DIMENSIONS TO BE CHECKED ON SITE. DRAWING TO BE READ IN CONJUNCTION WITH ALL RELEVANT DOCUMENTS. ©THE COPYRIGHT OF THIS DRAWING IS THE PROPERTY OF DAVID DELAMARE.



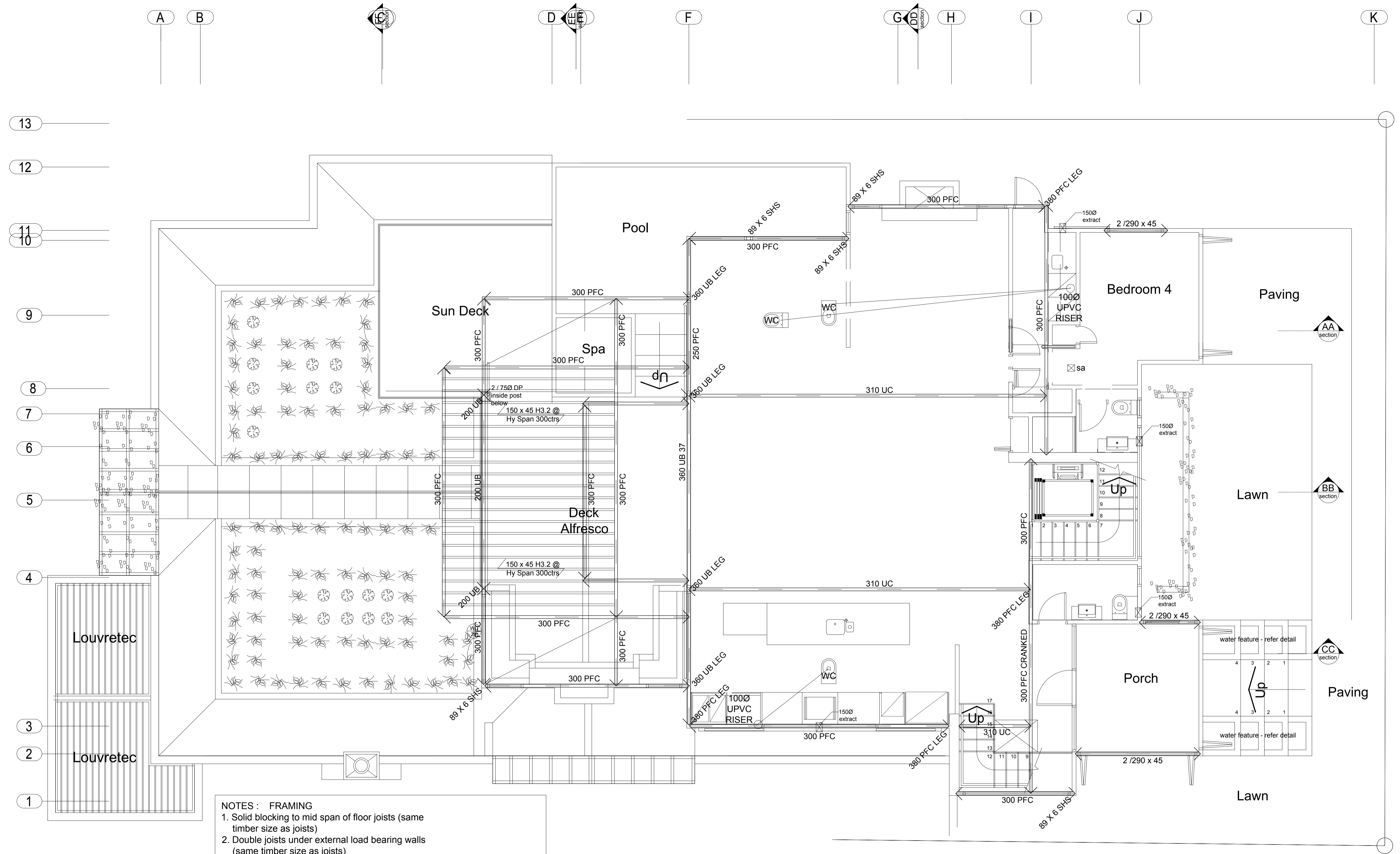

- NOTES : FRAMING**
1. Solid blocking to mid span of floor joists (same timber size as joists)
  2. Double joists under external load bearing walls (same timber size as joists)
  3. Holding down fixing sizes for Bottom plate  
internal walls - 4kN connection @900ctrs.  
external walls - 8kN connections @900ctrs.
  4. Top plate to stud fixing - 2/90 x 3.15 end nails & 2 wire dogs. Top Plate to rafter fixing 2/90 x 3.15 skew nails & strap fixing (4/30 x 3.15mm nails to both rafter & top plate). Purlin fixing 1/14g self-drilling type 17 screw, 100mm long
  5. Lintel Fixing - 25 x 1 strap with 6/30 x 25mm nails into both Lintel & stud. Lintels within 400mm of top plate 2 x 90 x 45 trimming studs. Lintels more than 400mm 3 x 90 x 45 trimming studs
  6. All Timber to be SG8 unless noted otherwise  
All Beam / Lintel Supports to be 2/90x45 Double Studs Posts U.N.O.

Third Floor Framing  
scale 1:50

Revisions	General notes

NOTE:  
**STAGE 2  
CONSENT**

59 ROSEBERRY AVE BIRKENHEAD AUCKLAND TEL (09)418 2432 FAX (09)419 5142  
 APARTMENT DEVELOPMENT  
 81 SARSFIELD STREET, HERNE BAY

**DELAMARE ARCHITECTS**

THIRD FLOOR FLOOR FRAMING  
 Drawing Reference: SAR 009  
 Date: DEC'17  
 Scale: 1/50 @ A1  
 Job no. revision  
 Cod ref SAR  
 CADREF

USE SQUARE DIMENSIONS. DO NOT SCALE FROM DRAWING. ALL LEVELS AND DIMENSIONS TO BE CHECKED ON SITE. DRAWING TO BE READ IN CONJUNCTION WITH ALL RELEVANT DOCUMENTS. ©THE COPYRIGHT OF THIS DRAWING IS THE PROPERTY OF DAVID DELAMARE.

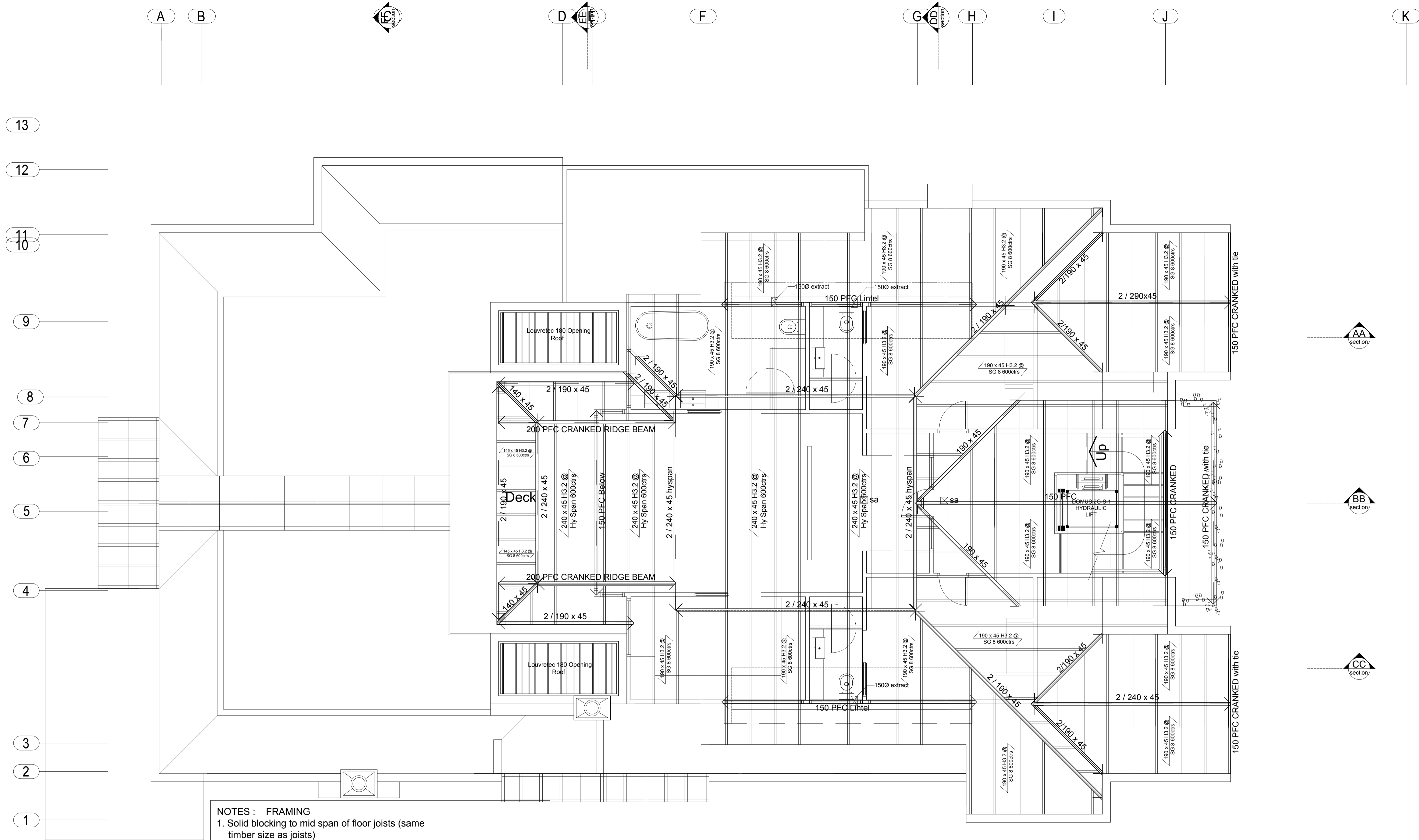

- NOTES : FRAMING**
1. Solid blocking to mid span of floor joists (same timber size as joists)
  2. Double joists under external load bearing walls (same timber size as joists)
  3. Holding down fixing sizes for Bottom plate  
internal walls - 4kN connection @900ctrs.  
external walls - 8kN connections @900ctrs.
  4. Top plate to stud fixing - 2/90 x 3.15 end nails & 2 wire dogs. Top Plate to rafter fixing 2/90 x 3.15 skew nails & strap fixing (4/30 x 3.15mm nails to both rafter & top plate). Purlin fixing 1/14g self-drilling type 17 screw, 100mm long
  5. Lintel Fixing - 25 x 1 strap with 6/30 x 25mm nails into both Lintel & stud. Lintels within 400mm of top plate 2 x 90 x 45 trimming studs. Lintels more than 400mm 3 x 90 x 45 trimming studs
  6. All Timber to be SG8 unless noted otherwise

Upper Roof Framing  
scale 1:50

Revisions	General notes

NOTE:  
**STAGE 2  
CONSENT**

59 ROSEBERRY AVE BIRKENHEAD AUCKLAND TEL (09)418 2432 FAX (09)419 5142  
 APARTMENT DEVELOPMENT  
 81 SARSFIELD STREET, HERNE BAY

**DELAMARE ARCHITECTS**

Date DEC'17  
 Scale 1/50 @ A1  
 Drawing Reference  
 Job no SAR 010  
 Revision  
 Cad ref SAR  
 CADREF

USE SQUARE DIMENSIONS. DO NOT SCALE FROM DRAWING.  
 ALL LEVELS AND DIMENSIONS TO BE CHECKED ON SITE.  
 DRAWING TO BE READ IN CONJUNCTION WITH ALL  
 RELEVANT DOCUMENTS.  
 ©THE COPYRIGHT OF THIS DRAWING IS THE PROPERTY  
 OF DAVID DELAMARE

This project is to be a staged building consent.  
**Stage 1 - All below ground work, drainage, piling, retaining, footings and concrete slabs on ground.**  
**Stage 2 - Remainder of Project**

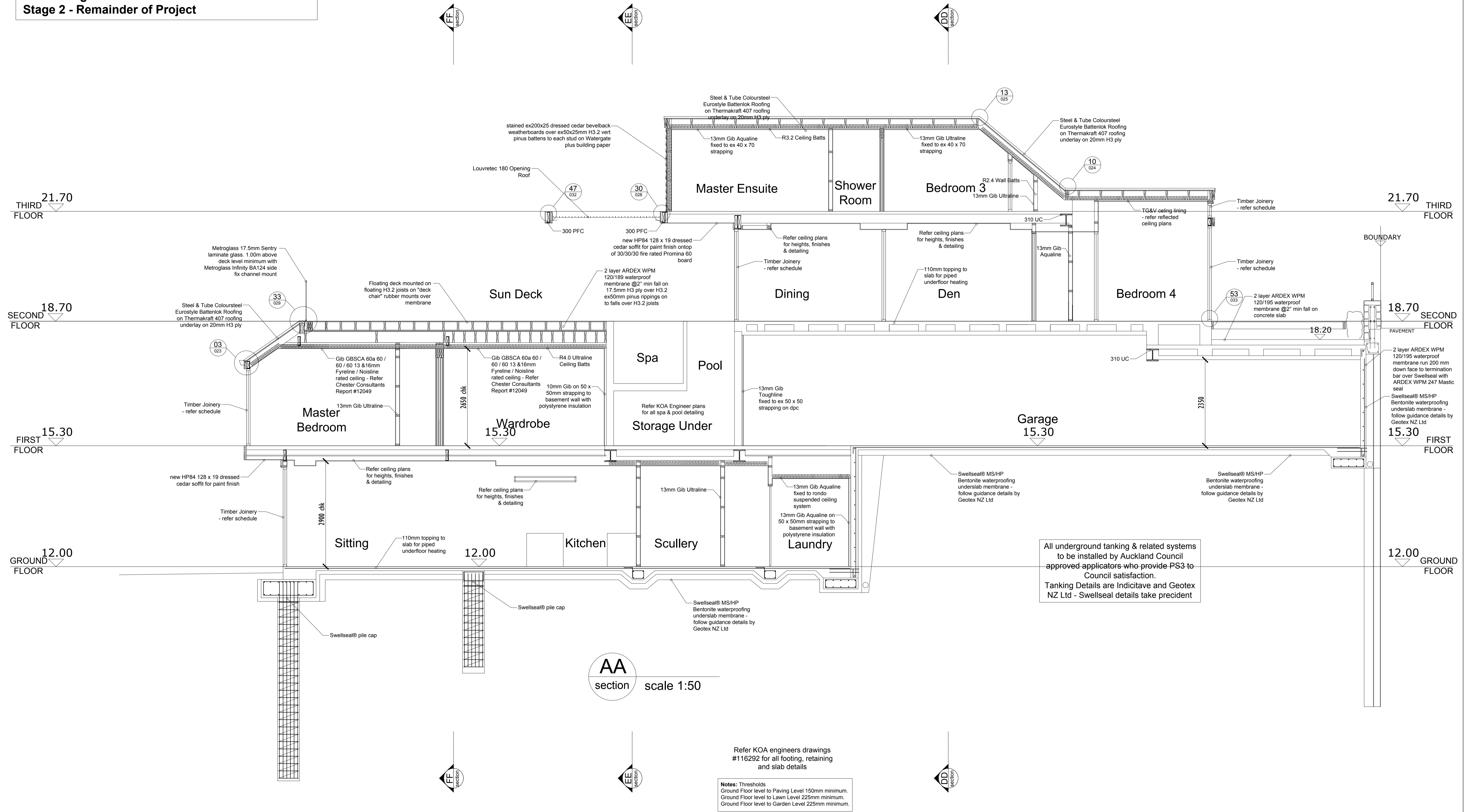

AA section scale 1:50

Refer KOA engineers drawings #116292 for all footing, retaining and slab details

Notes: Thresholds  
 Ground Floor level to Paving Level 150mm minimum.  
 Ground Floor level to Lawn Level 225mm minimum.  
 Ground Floor level to Garden Level 225mm minimum.

All underground tanking & related systems to be installed by Auckland Council approved applicators who provide PS3 to Council satisfaction. Tanking Details are Indicative and Geotex NZ Ltd - Swellseal details take precedent

Revisions	General notes

NOTE:  
**AMENDMENT 09/18**

59 ROSEBERRY AVE, BIRKENHEAD, AUCKLAND TEL (09)418 2432 FAX (09)419 5142  
 APARTMENT DEVELOPMENT  
 81 SANSFIELD STREET, HERNE BAY

**DELAMARE ARCHITECTS**

SECTION Drawing Reference Date: DEC'17  
 SAR 011 Scale: 1/50 @ A1  
 C Cad ref: SAR  
 CADREF

USE FIGURED DIMENSIONS. DO NOT SCALE FROM DRAWING. ALL LEVELS AND DIMENSIONS TO BE CHECKED ON SITE. DRAWING TO BE READ IN CONJUNCTION WITH ALL RELEVANT DOCUMENTS. ©THE COPYRIGHT OF THIS DRAWING IS THE PROPERTY OF DAVID DELAMARE

**This project is to be a staged building consent.**  
**Stage 1 - All below ground work, drainage, piling, retaining, footings and concrete slabs on ground.**  
**Stage 2 - Remainder of Project**

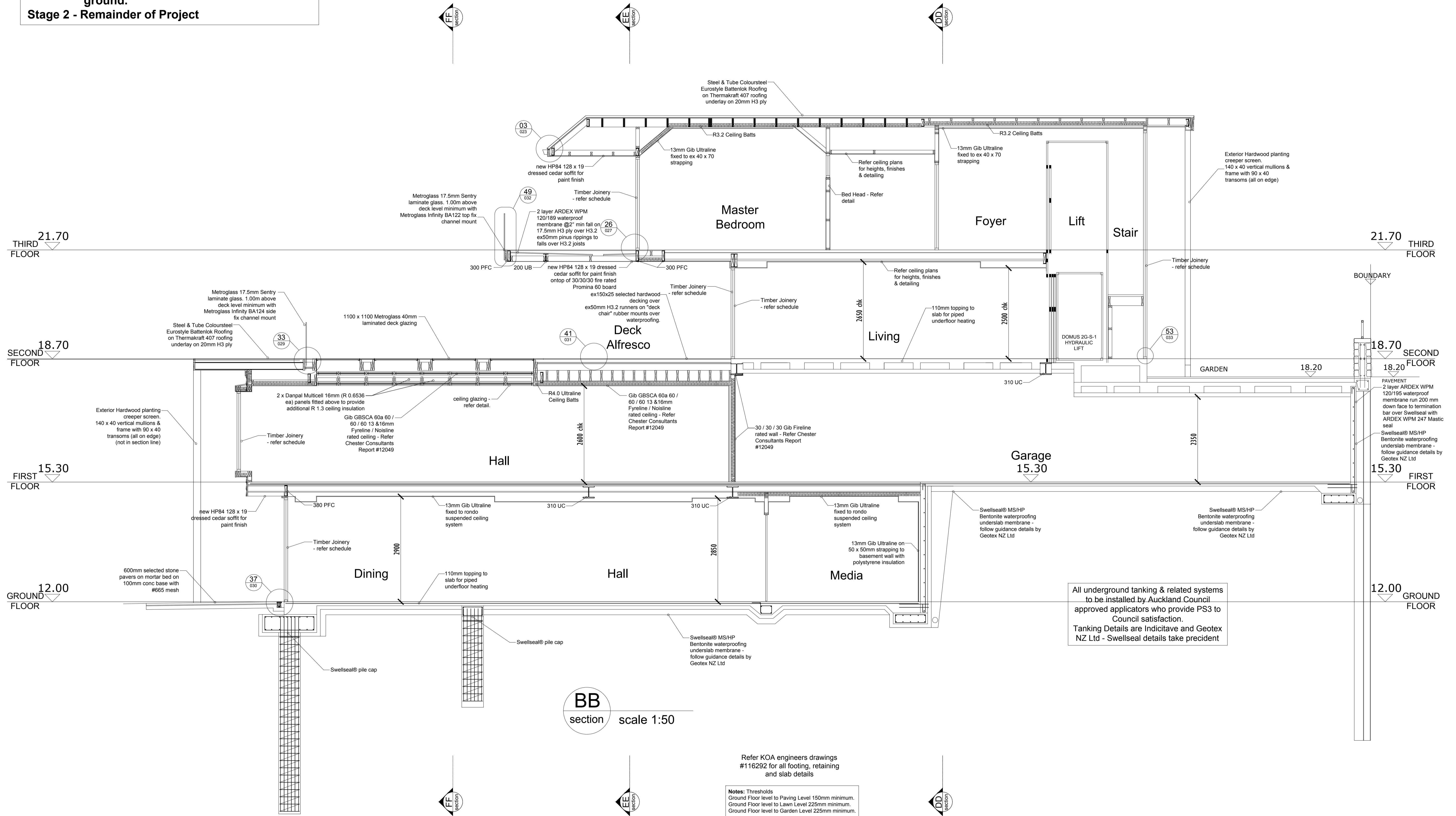

**BB**  
 section scale 1:50

Refer KOA engineers drawings #116292 for all footing, retaining and slab details

Notes: Thresholds  
 Ground Floor level to Paving Level 150mm minimum.  
 Ground Floor level to Lawn Level 225mm minimum.  
 Ground Floor level to Garden Level 225mm minimum.

Revisions	General notes

NOTE:  
**AMENDMENT**  
**09/18**

59 ROSEBERRY AVE, BIRKENHEAD, AUCKLAND. TEL (09)418 2432 FAX (09)419 5142  
**APARTMENT DEVELOPMENT**  
 81 SANSFIELD STREET, HERNE BAY

**DELAMARE ARCHITECTS**

Date: DEC'17  
 Scale: 1/50 @ A1  
 Drawing Reference: SAR 012 C  
 Drawing Reference: SAR 012 C  
 Drawing Reference: SAR 012 C

USE FIGURED DIMENSIONS. DO NOT SCALE FROM DRAWING. ALL LEVELS AND DIMENSIONS TO BE CHECKED ON SITE. DRAWING TO BE READ IN CONJUNCTION WITH ALL RELEVANT DOCUMENTS. © THE COPYRIGHT OF THIS DRAWING IS THE PROPERTY OF DAVID DELAMARE

This project is to be a staged building consent.  
**Stage 1 - All below ground work, drainage, piling, retaining, footings and concrete slabs on ground.**  
**Stage 2 - Remainder of Project**

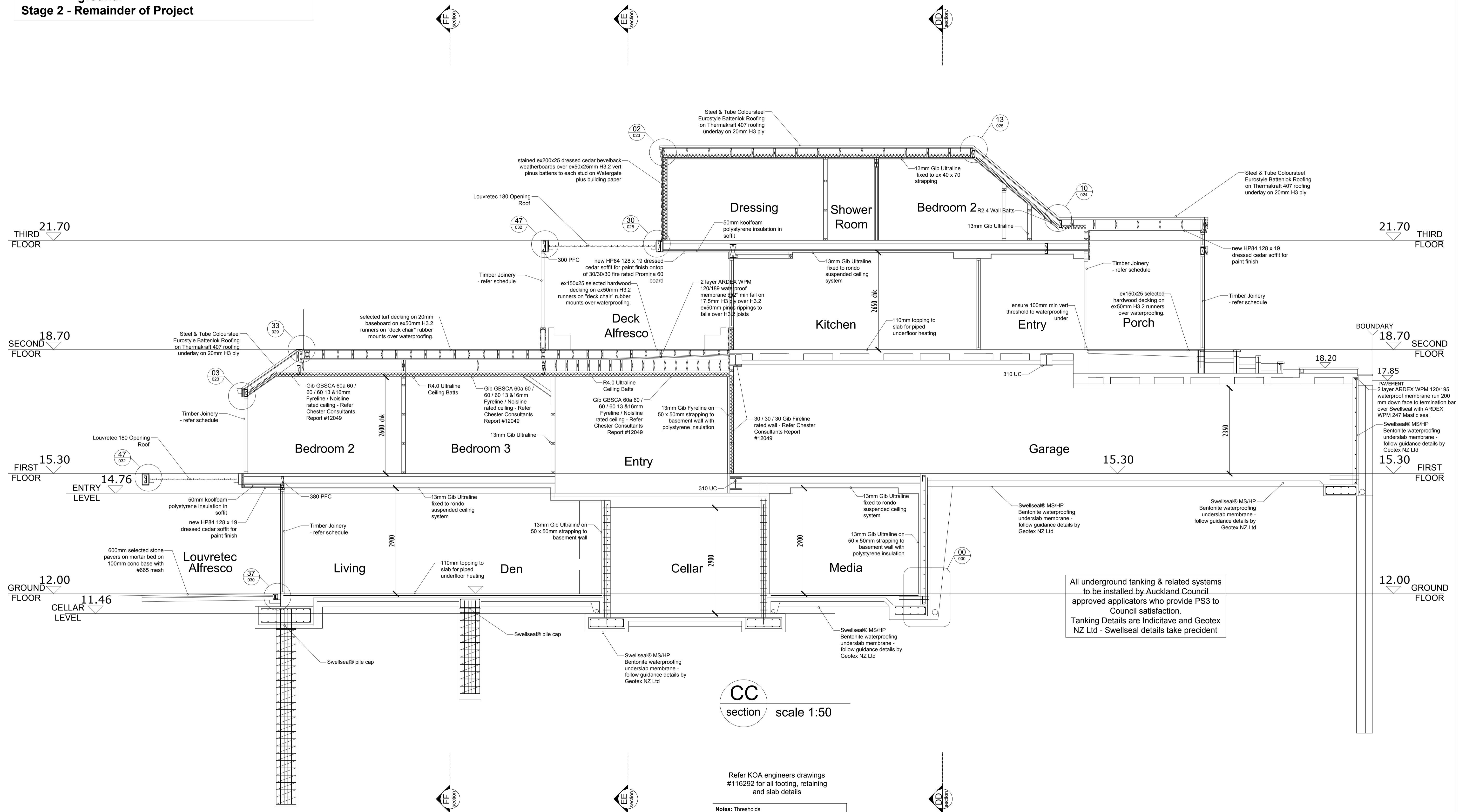

All underground tanking & related systems to be installed by Auckland Council approved applicators who provide PS3 to Council satisfaction. Tanking Details are Indicative and Geotex NZ Ltd - Swellseal details take precedent

CC section scale 1:50

Refer KOA engineers drawings #116292 for all footing, retaining and slab details

Notes: Thresholds  
 Ground Floor level to Paving Level 150mm minimum.  
 Ground Floor level to Lawn Level 225mm minimum.  
 Ground Floor level to Garden Level 225mm minimum.

Revisions	General notes

NOTE:  
**AMENDMENT 09/18**

59 ROSEBERRY AVE, BIRKENHEAD, AUCKLAND. TEL (09)418 2432. FAX (09)419 5142  
**APARTMENT DEVELOPMENT**  
 81 SANSFIELD STREET, HERNE BAY

**DELAMARE ARCHITECTS**

Drawing Reference: SAR 013 C  
 Date: DEC'17  
 Scale: 1/50 @ A1  
 Cad ref: SAR  
 CADREF

USE FIGURED DIMENSIONS. DO NOT SCALE FROM DRAWING. ALL LEVELS AND DIMENSIONS TO BE CHECKED ON SITE. DRAWING TO BE READ IN CONJUNCTION WITH ALL RELEVANT DOCUMENTS. © THE COPYRIGHT OF THIS DRAWING IS THE PROPERTY OF DAVID DELAMARE

This project is to be a staged building consent.  
**Stage 1 - All below ground work, drainage, piling, retaining, footings and concrete slabs on ground.**  
**Stage 2 - Remainder of Project**

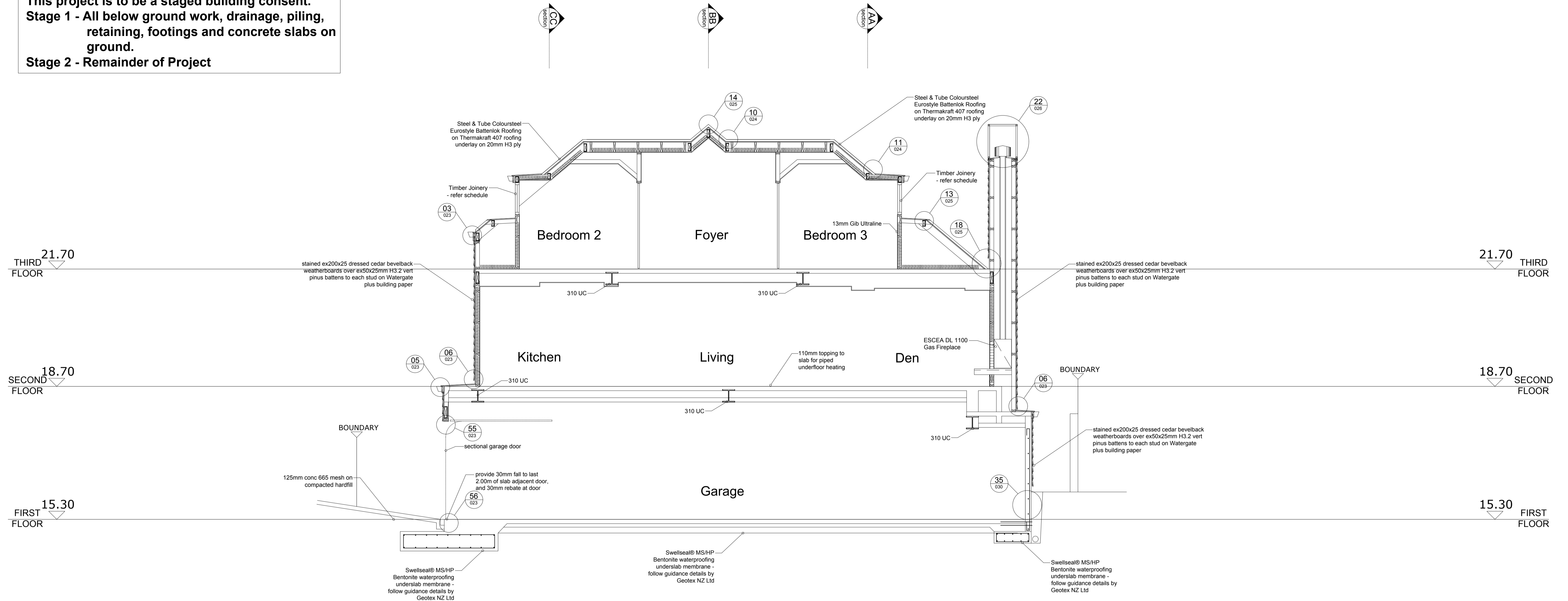

**DD**  
 section scale 1:50

All underground tanking & related systems to be installed by Auckland Council approved applicators who provide PS3 to Council satisfaction. Tanking Details are Indicative and Geotex NZ Ltd - Swellseal details take precedent

Refer KOA engineers drawings #116292 for all footing, retaining and slab details

**Notes:** Thresholds  
 Ground Floor level to Paving Level 150mm minimum.  
 Ground Floor level to Lawn Level 225mm minimum.  
 Ground Floor level to Garden Level 225mm minimum.

Revisions	General notes

NOTE:  
**AMENDMENT 09/18**

59 ROSEBERRY AVE, BIRKENHEAD, AUCKLAND. TEL (09)418 2432 FAX (09)419 5142  
**APARTMENT DEVELOPMENT**  
 81 SANSFIELD STREET, HERNE BAY

**DELAMARE ARCHITECTS**

Date: DEC'17  
 Scale: 1/50 @ A1  
 Drawing Reference: SAR 014  
 Cad ref: SAR  
 CADREF

USE FIGURED DIMENSIONS. DO NOT SCALE FROM DRAWING. ALL LEVELS AND DIMENSIONS TO BE CHECKED ON SITE. DRAWING TO BE READ IN CONJUNCTION WITH ALL RELEVANT DOCUMENTS. ©THE COPYRIGHT OF THIS DRAWING IS THE PROPERTY OF DAVID DELAMARE

This project is to be a staged building consent.  
**Stage 1 - All below ground work, drainage, piling, retaining, footings and concrete slabs on ground.**  
**Stage 2 - Remainder of Project**

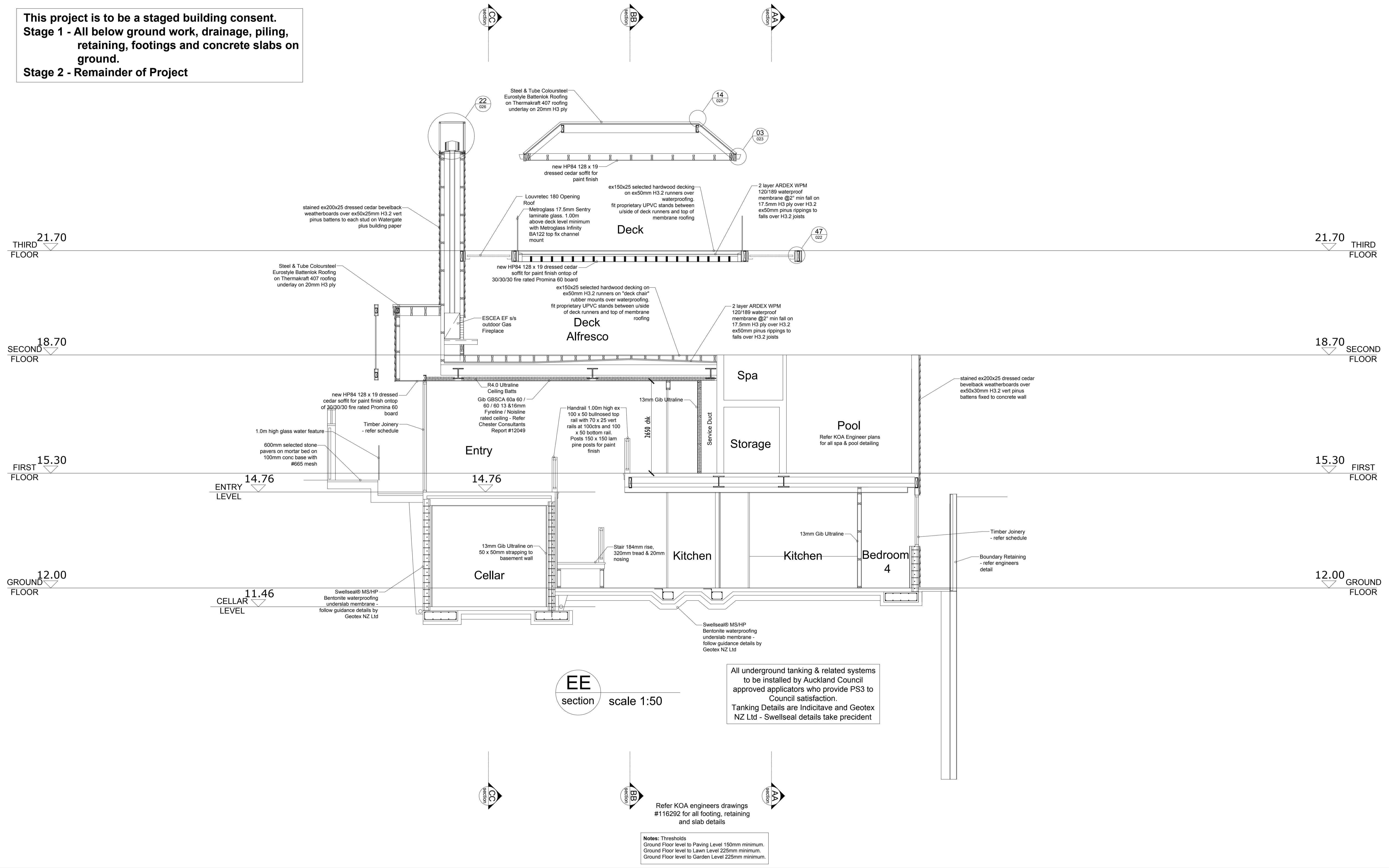

All underground tanking & related systems to be installed by Auckland Council approved applicators who provide PS3 to Council satisfaction.  
 Tanking Details are Indicative and Geotex NZ Ltd - Swellseal details take precedent

Refer KOA engineers drawings #116292 for all footing, retaining and slab details

Notes: Thresholds  
 Ground Floor level to Paving Level 150mm minimum.  
 Ground Floor level to Lawn Level 225mm minimum.  
 Ground Floor level to Garden Level 225mm minimum.

Revisions	General notes

NOTE:  
**AMENDMENT 09/18**

59 ROSEBERRY AVE, BIRKENHEAD, AUCKLAND. TEL (09)418 2432 FAX (09)419 5142  
 APARTMENT DEVELOPMENT  
 81 SANSFIELD STREET, HERNE BAY

**DELAMARE ARCHITECTS**

SECTION Drawing Reference Date: DEC'17  
 SAR 015 Scale: 1/50 @ A1  
 C Cad ref: SAR  
 CADREF

USE FIGURED DIMENSIONS. DO NOT SCALE FROM DRAWING. ALL LEVELS AND DIMENSIONS TO BE CHECKED ON SITE. DRAWING TO BE READ IN CONJUNCTION WITH ALL RELEVANT DOCUMENTS. © THE COPYRIGHT OF THIS DRAWING IS THE PROPERTY OF DAVID DELAMARE

This project is to be a staged building consent.  
**Stage 1 - All below ground work, drainage, piling, retaining, footings and concrete slabs on ground.**  
**Stage 2 - Remainder of Project**

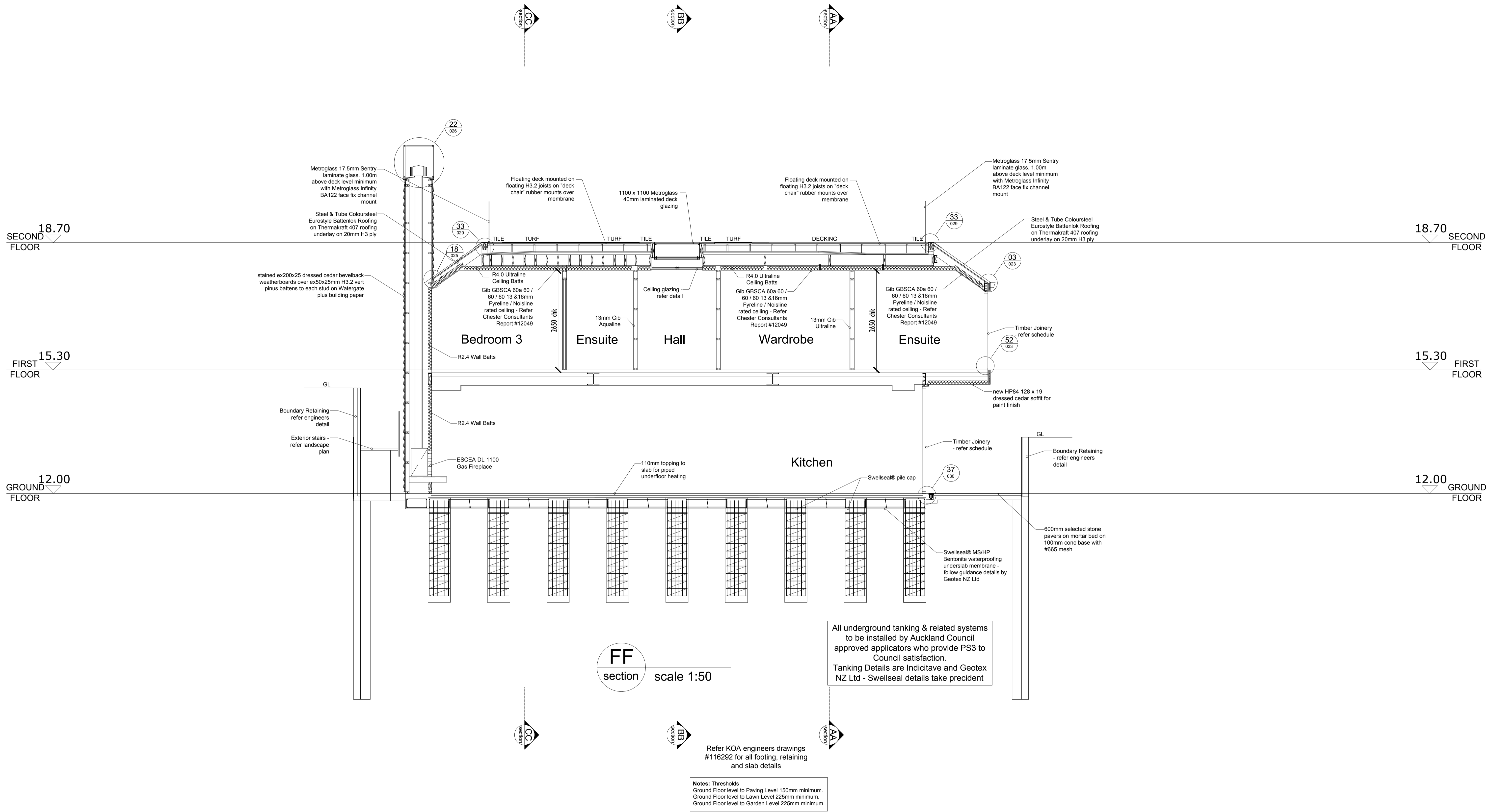

Revisions	General notes

NOTE:  
**AMENDMENT**  
**09/18**

59 ROSEBERRY AVE, BIRKENHEAD, AUCKLAND. TEL (09)418 2432. FAX (09)419 5142  
**APARTMENT DEVELOPMENT**  
 81 Sarsfield Street, Herne Bay

Date: DEC'17  
 Scale: 1/50 @ A1  
 Drawing Reference: SAR 016  
 Revision: B  
 Cad ref: SAR  
 CADREF

**DELAMARE ARCHITECTS**

USE FIGURED DIMENSIONS. DO NOT SCALE FROM DRAWING. ALL LEVELS AND DIMENSIONS TO BE CHECKED ON SITE. DRAWING TO BE READ IN CONJUNCTION WITH ALL RELEVANT DOCUMENTS. © THE COPYRIGHT OF THIS DRAWING IS THE PROPERTY OF DAVID DELAMARE.



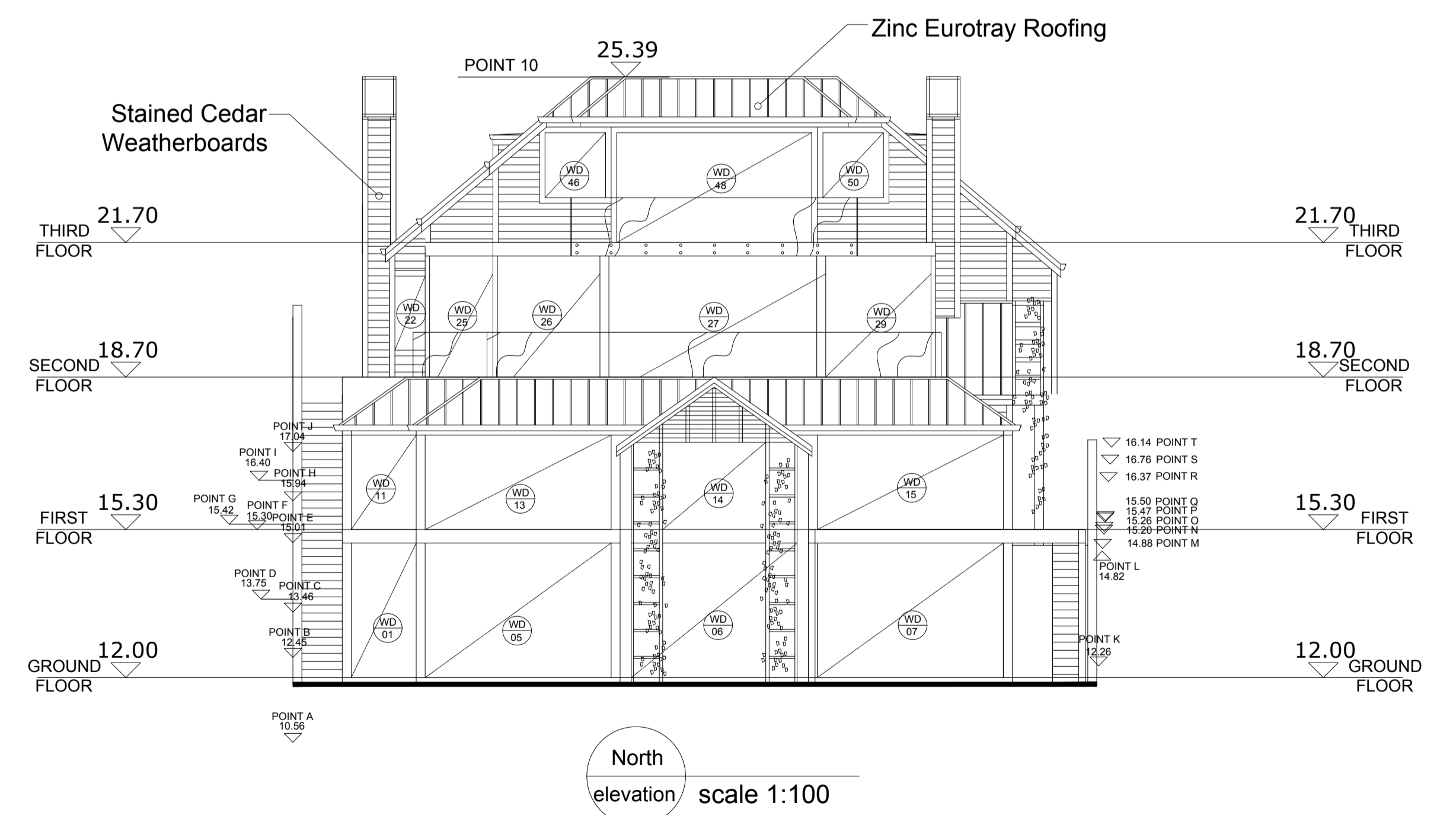
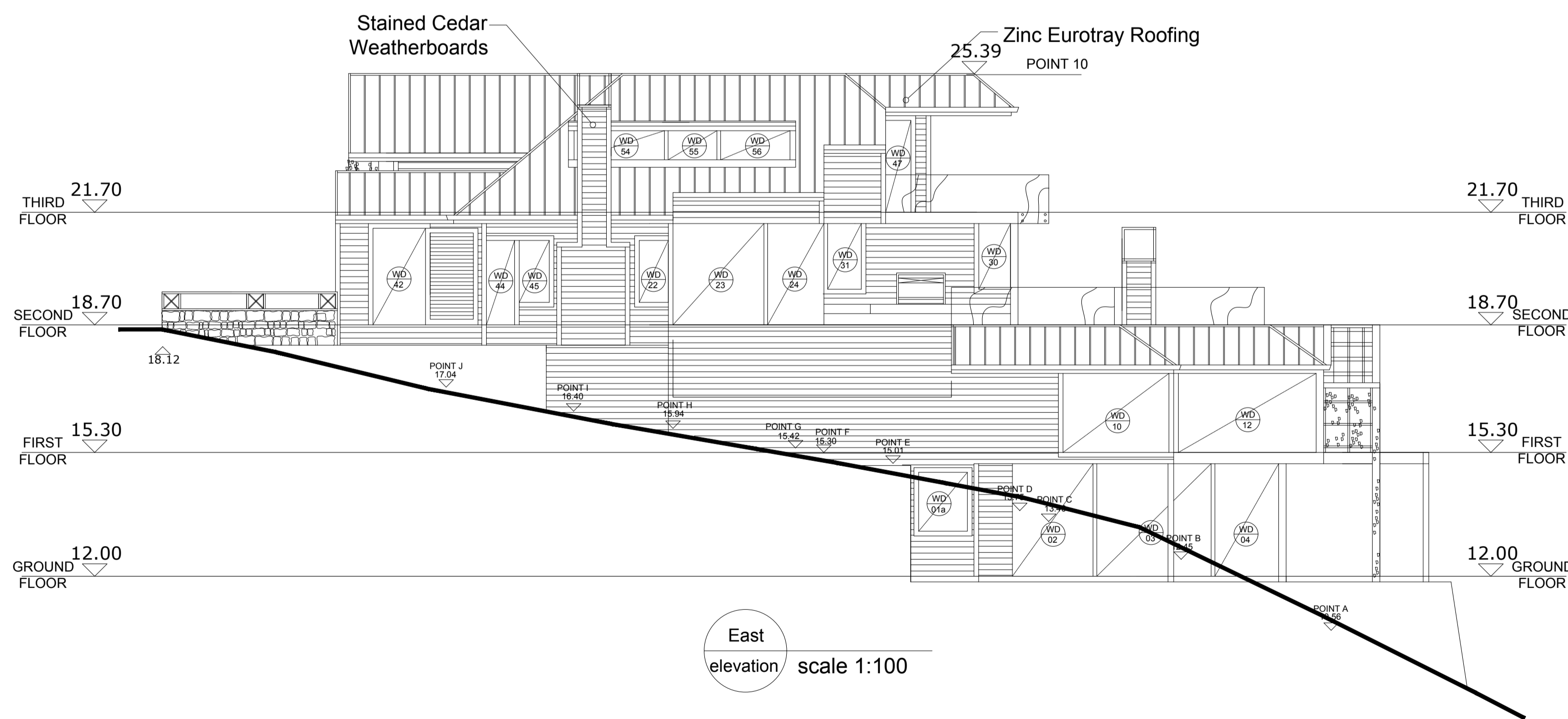
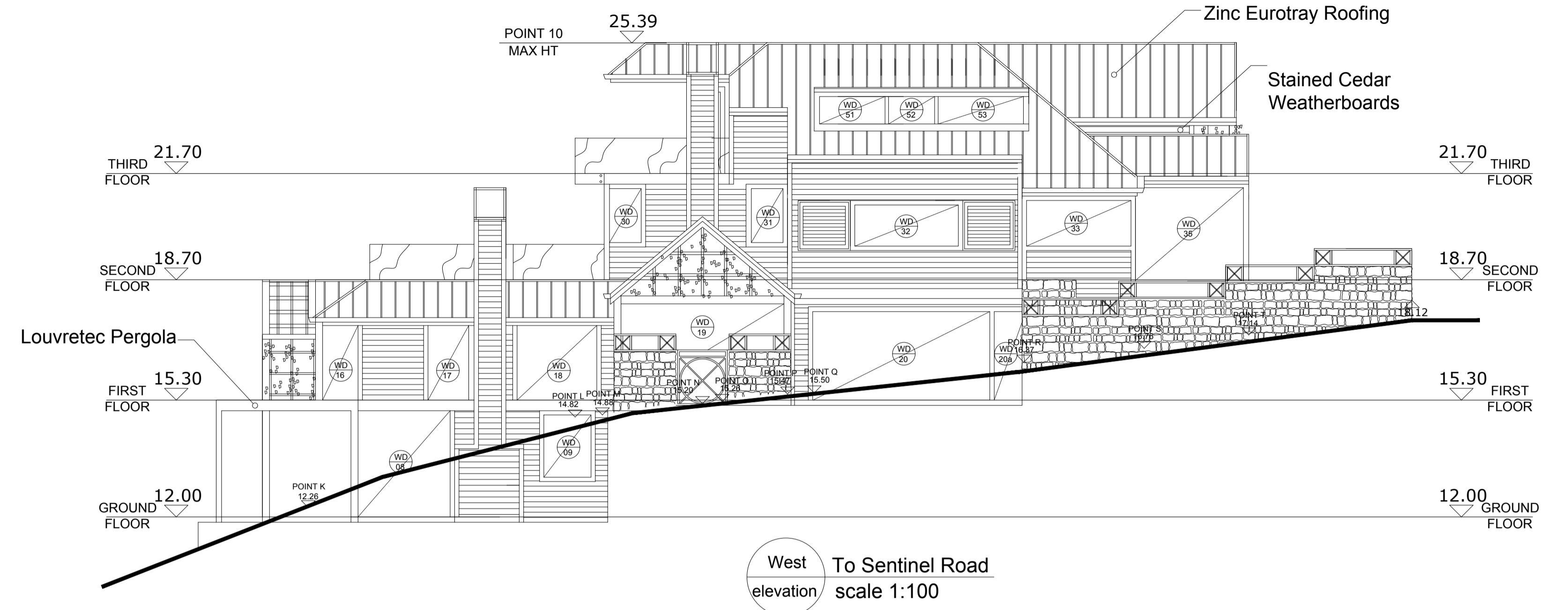
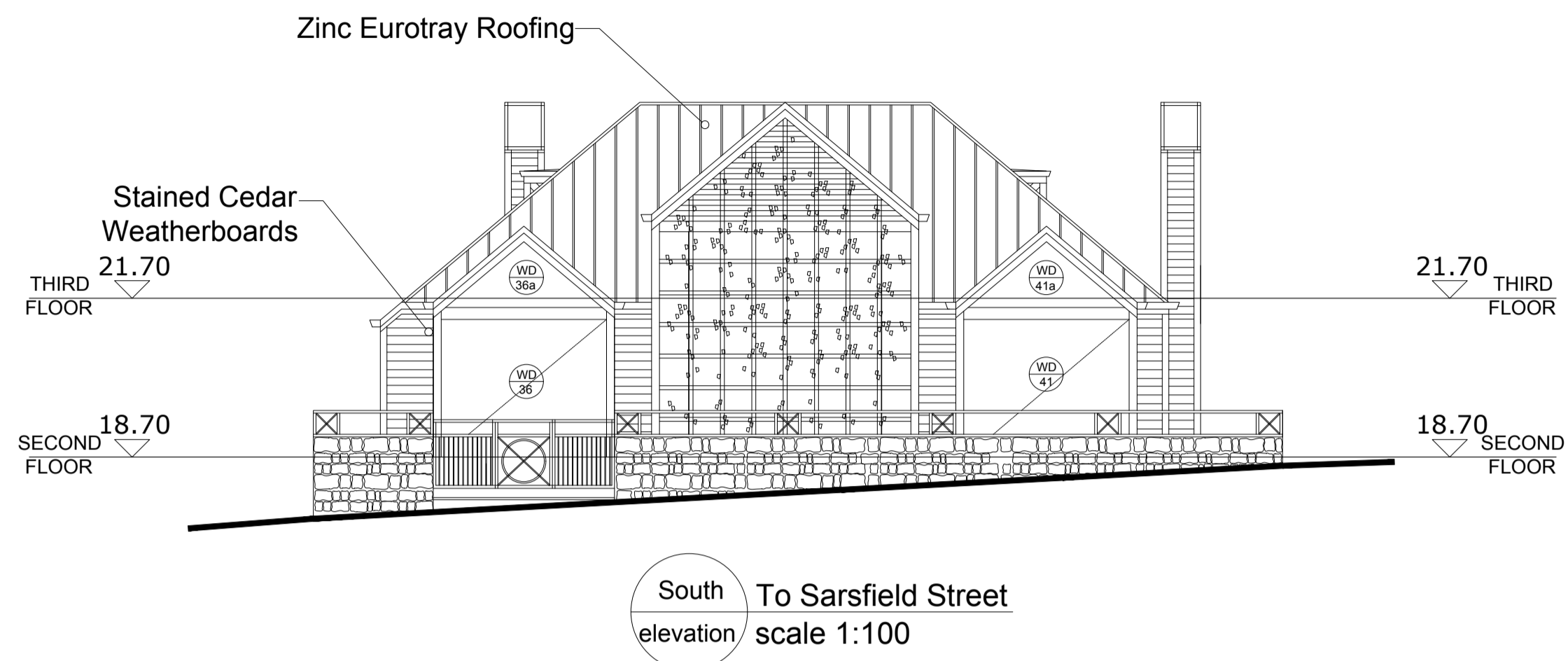

Revisions	General notes

NOTE:  
**AMENDMENT**  
**09/18**

59 ROSEBERRY AVE. BIRKENHEAD AUCKLAND TEL (09)418 2432 FAX (09)419 5142  
 APARTMENT DEVELOPMENT  
 81 SARSFIELD STREET, HERNE BAY

**DELAMARE ARCHITECTS**

Date DEC'17  
 Scale 1/100 @ A1  
 Drawing Reference SAR 017  
 ELEVATIONS

USE FIGURED DIMENSIONS. DO NOT SCALE FROM DRAWING. ALL LEVELS AND DIMENSIONS TO BE CHECKED ON SITE. DRAWING TO BE READ IN CONJUNCTION WITH ALL RELEVANT DOCUMENTS. © THE COPYRIGHT OF THIS DRAWING IS THE PROPERTY OF DAVID DELAMARE.

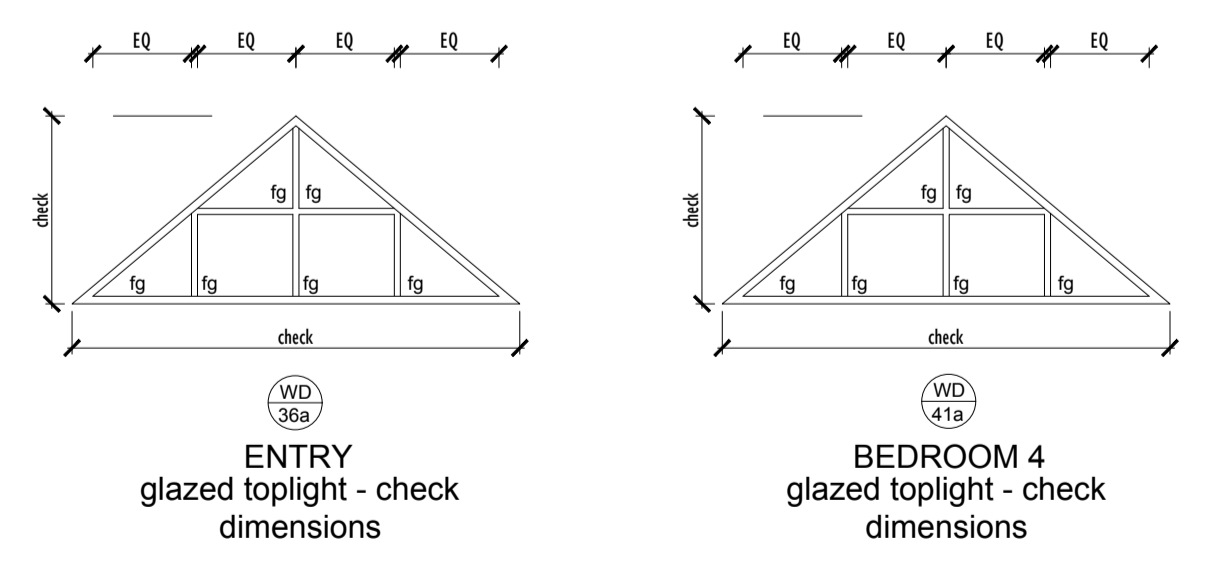
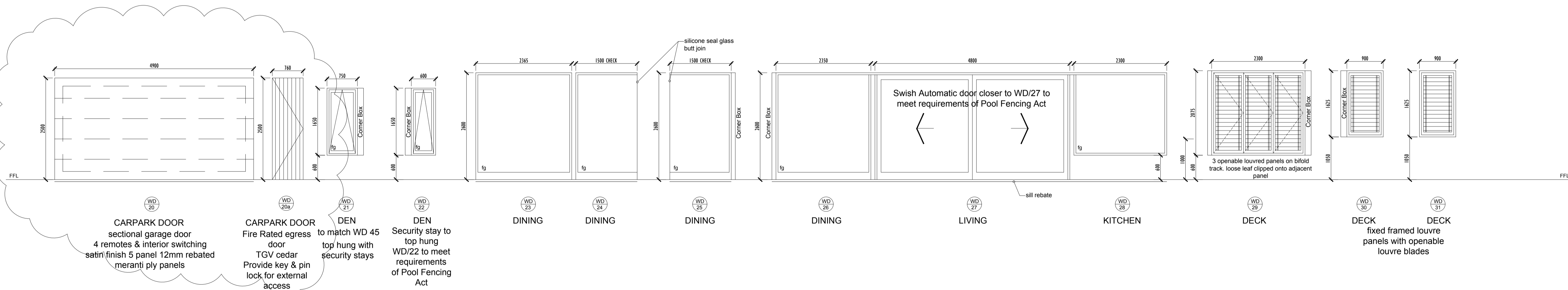
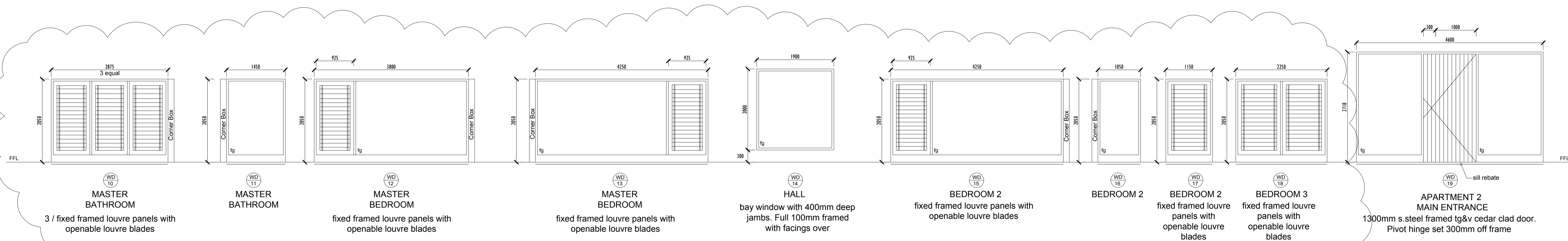
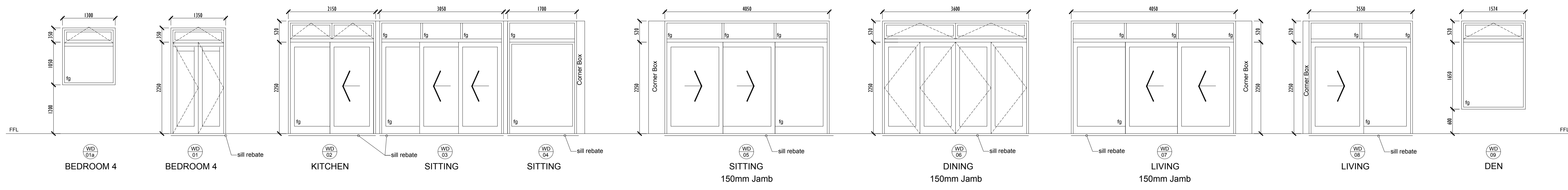

- NOTES:**
- All joinery hardware 316 stainless steel
  - Openable louvre blades to be divided into practical size panels with separate opening
  - All glazing units back putted & secured with glazing beads
  - Glue - Loctite Durobond from Glue Guru
  - Filler - polyester lightweight
  - Primer - Oil based primer

**IMPORTANT**  
Confirm all Joinery dimensions on site prior to manufacture

- JOINERY NOTES: TIMBER**
1. Allow for ex 150 x 25 cedar facing + 19mm scribes to all frames.
  2. Fit ex 25mm cedar corner boxes where shown.
  3. Fit continuous copper head and copper sill flashings with folded returns.
  4. **Confirm all dimensions on site prior to manufacture**
  5. Joinery shown viewed from outside
  6. Fit full length sill flashings to all frames.
  7. **All Glazing shall be N.Z.S.4223 double glazed**
  8. Design for High Wind Zone requirements
  9. Standard joinery manufacturers flat cills, heads, jambs and flashing. Clear No 1 Cedar sashes & louvre blades. All frames joinery grade pinus H3.2 for paint finish
  10. Refer Specification for timber joinery finishing details

Revisions	General notes

NOTE:  
**AMENDMENT**  
**09/18**

59 ROSEBERRY AVE. BIRKENHEAD AUCKLAND TEL (09)418 2432 FAX (09)419 5142  
APARTMENT DEVELOPMENT  
81 SANSFIELD STREET, HERNE BAY

Date DEC'17  
Scale 1/50 @ A1  
Drawing Reference SAR 018  
Revision B  
CADREF

**DELAMARE ARCHITECTS**

USE FIGURED DIMENSIONS. DO NOT SCALE FROM DRAWING. ALL LEVELS AND DIMENSIONS TO BE CHECKED ON SITE. DRAWING TO BE READ IN CONJUNCTION WITH ALL RELEVANT DOCUMENTS. © THE COPYRIGHT OF THIS DRAWING IS THE PROPERTY OF DAVID DELAMARE

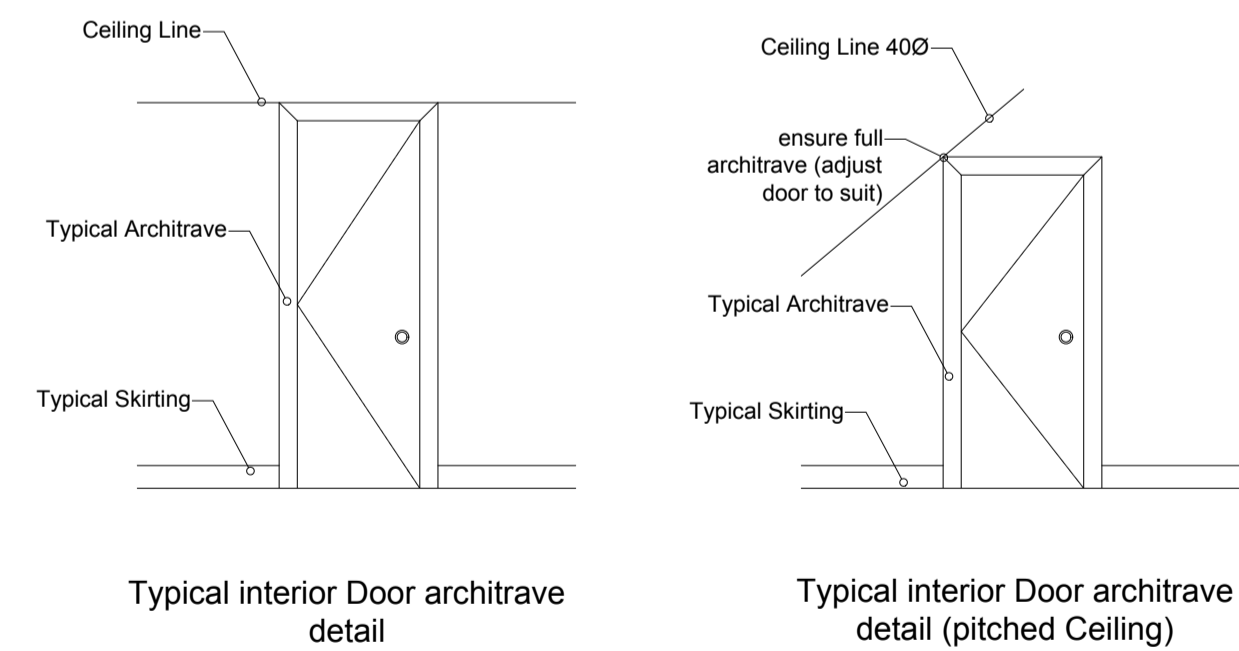
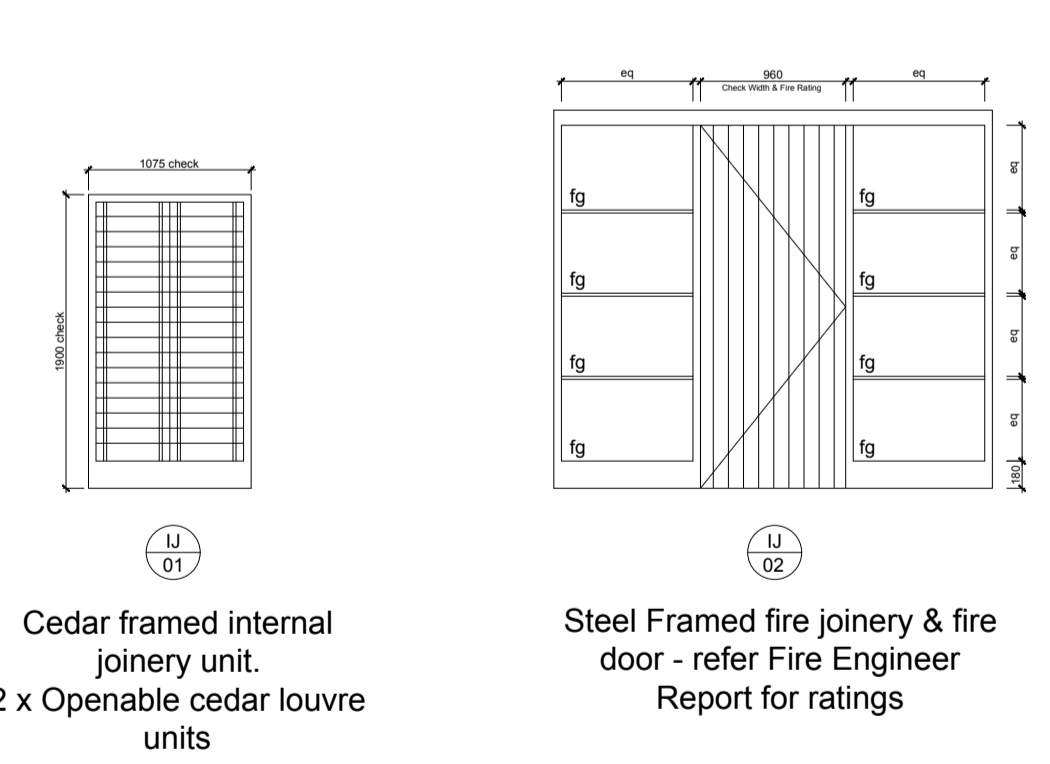
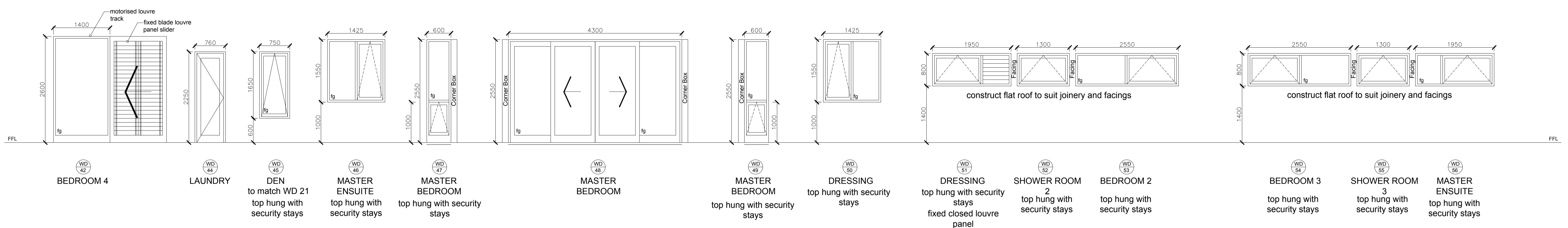
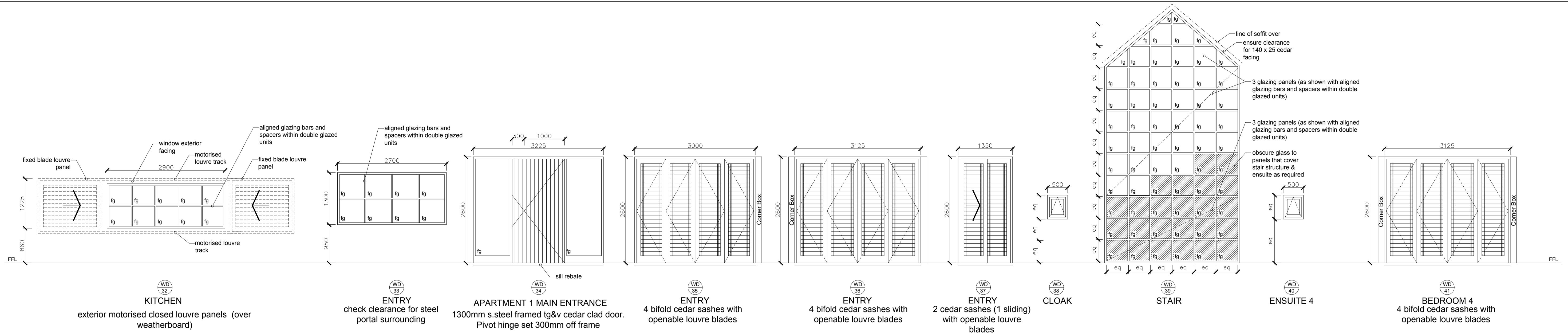

**NOTES:**

- All joinery hardware 316 stainless steel
- Openable louvre blades to be divided into practical size panels with separate opening
- All glazing units back putted & secured with glazing beads
- Glue - Loctite Durobond from Glue Guru
- Filler - polyester lightweight
- Primer - Oil based primer

**IMPORTANT**  
**Confirm all Joinery dimensions on site prior to manufacture**

**JOINERY NOTES: TIMBER**

1. Allow for ex 150 x 25 cedar facing + 19mm scribers to all frames.
2. Fit ex 25mm cedar corner boxes where shown.
3. Fit continuous copper head and copper sill flashings with folded returns.
4. **Confirm all dimensions on site prior to manufacture**
5. Joinery shown viewed from outside
6. Fit full length sill flashings to all frames.
7. **All Glazing shall be N.Z.S.4223 double glazed**
8. Design for High Wind Zone requirements
9. Standard joinery manufacturers flat cills, heads, jams and flashing. Clear No 1 Cedar sashes & louvre blades. All frames joinery grade pinus H3.2 for paint finish
10. Refer Specification for timber joinery finishing details

Revisions	General notes

NOTE:  
**STAGE 2**  
**CONSENT**

59 ROSEBERRY AVE BIRKENHEAD AUCKLAND TEL (09)418 2432 FAX (09)419 5142  
 APARTMENT DEVELOPMENT  
 81 SARFIELD STREET, HERNE BAY

**DELAMARE ARCHITECTS**

Date DEC'17  
 Scale 1/50 @ A1  
 Drawing Reference  
 Job no. SAR 019  
 Rev no. 019  
 revision  
 Cod ref SAR  
 CADREF

USE SQUARE DIMENSIONS. DO NOT SCALE FROM DRAWING. ALL LEVELS AND DIMENSIONS TO BE CHECKED ON SITE. DRAWING TO BE READ IN CONJUNCTION WITH ALL RELEVANT DOCUMENTS. © THE COPYRIGHT OF THIS DRAWING IS THE PROPERTY OF DAVID DELAMARE.

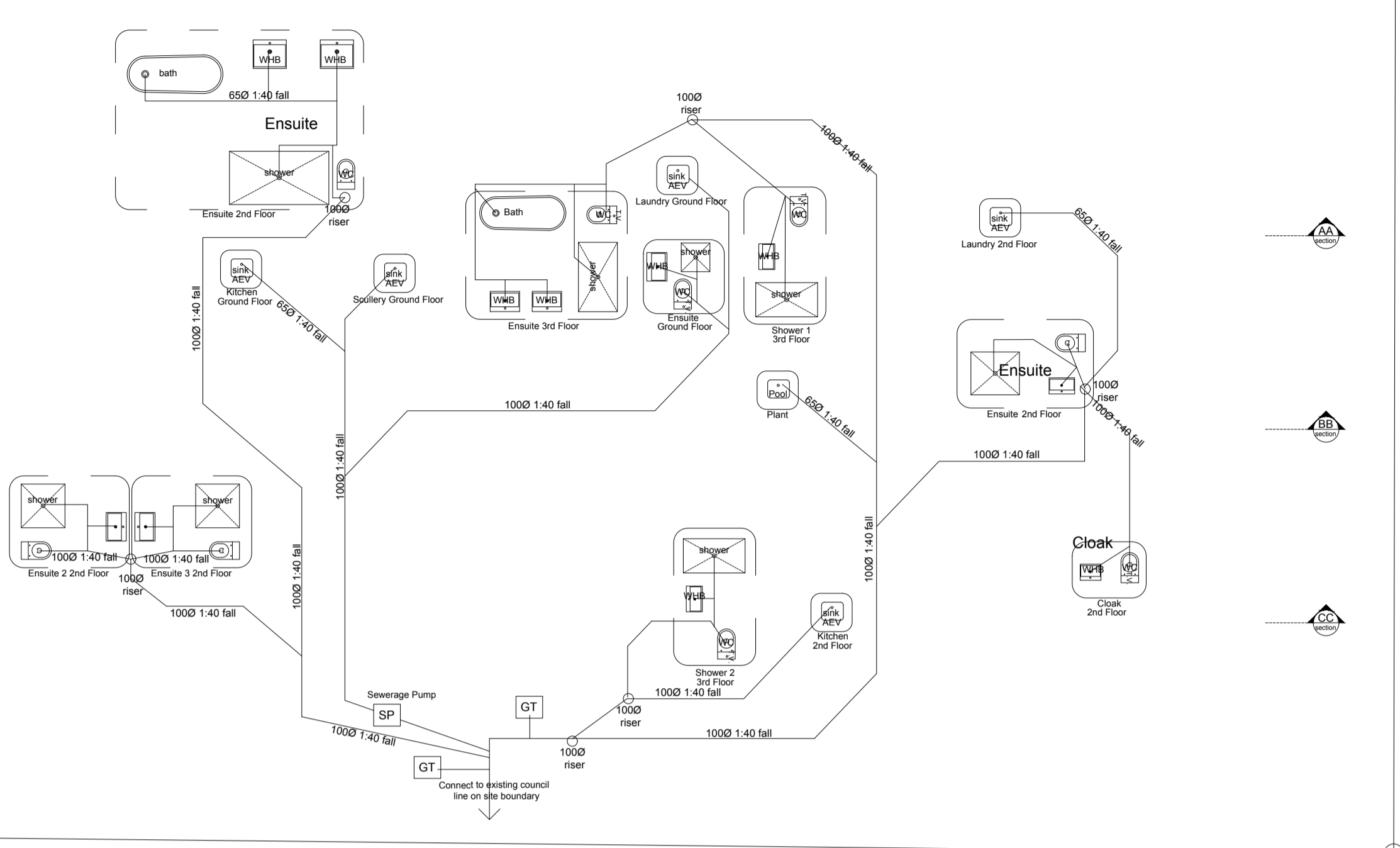

**Plumbing Plan**  
N.T.S., as per A.S.3500

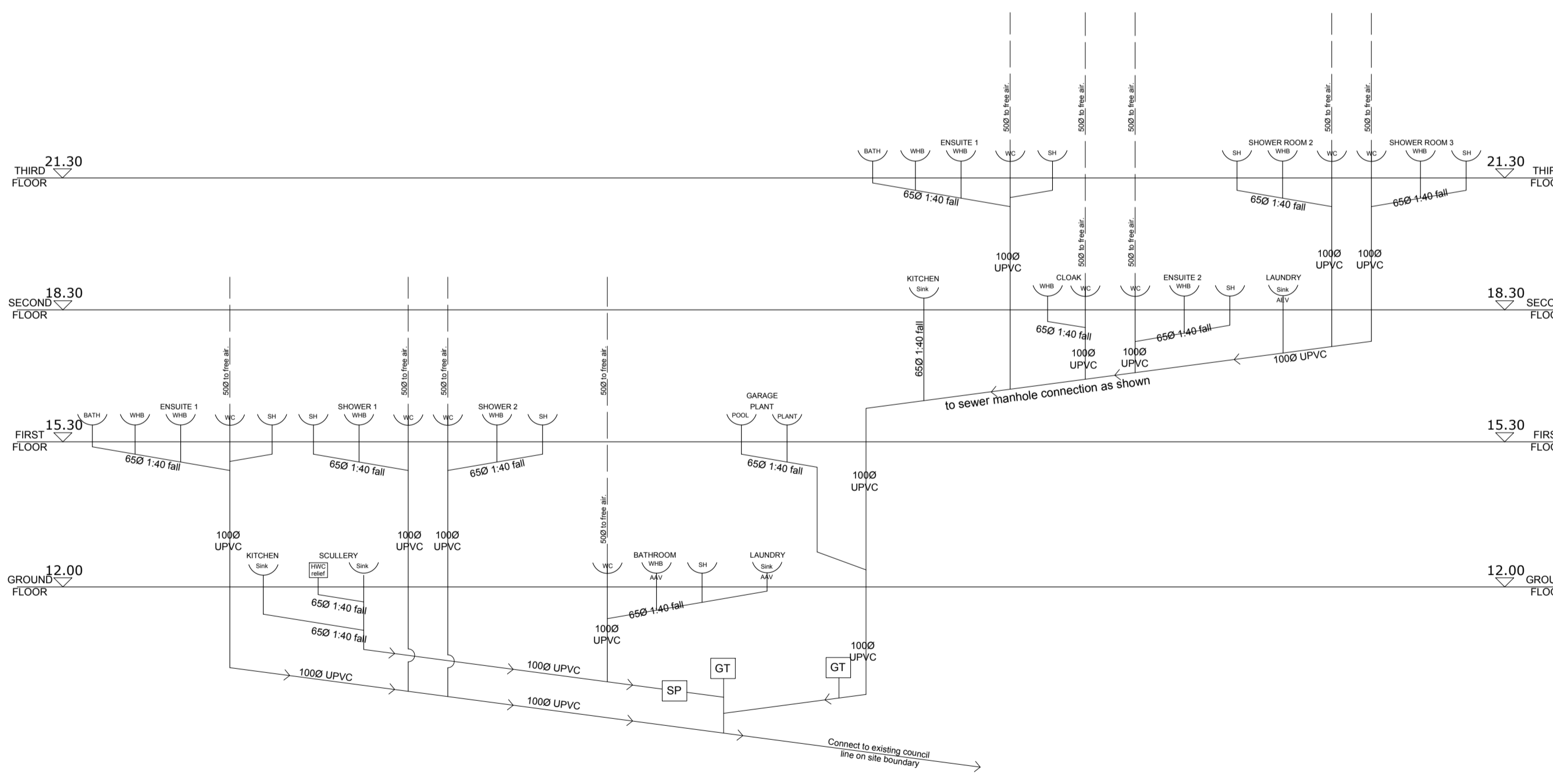

**Plumbing Schematic**  
N.T.S., as per A.S.3500

**NOTES Plumbing + Drainage**  
1. All plumbing pipework concealed in frame / structure  
2. All plumbing/drainage to comply with AS 3500

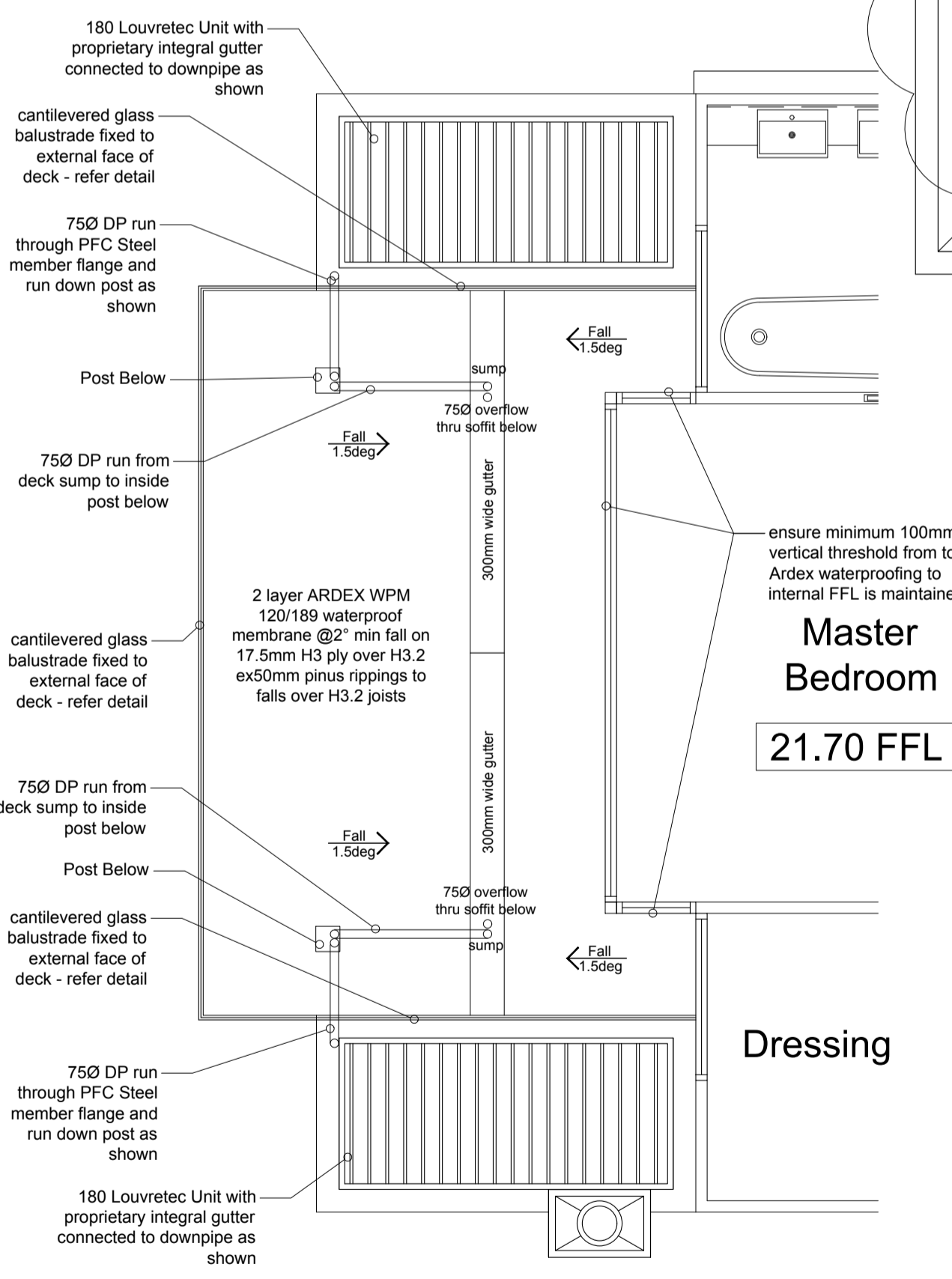

**Upper Deck Membrane Plan**  
scale 1:50

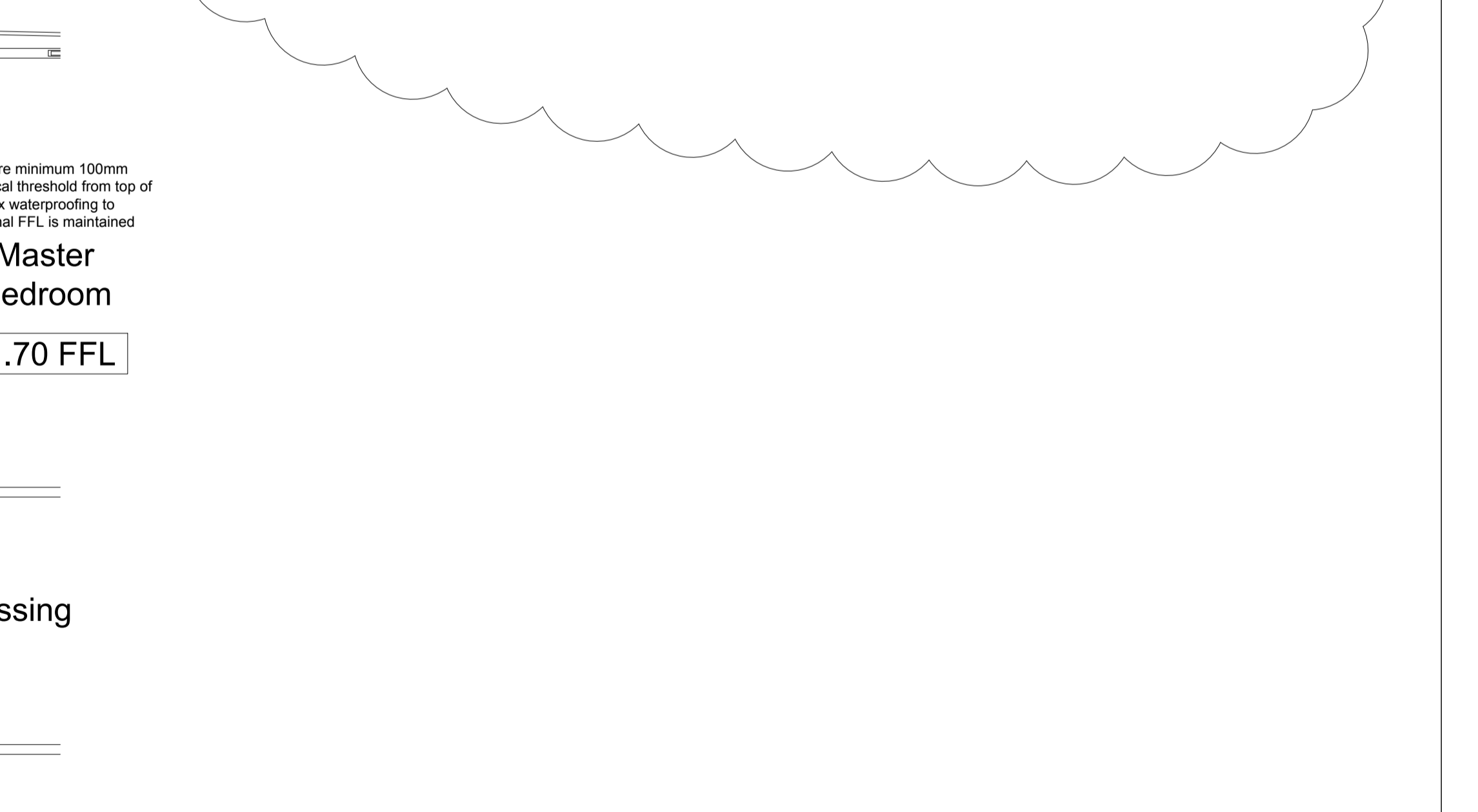
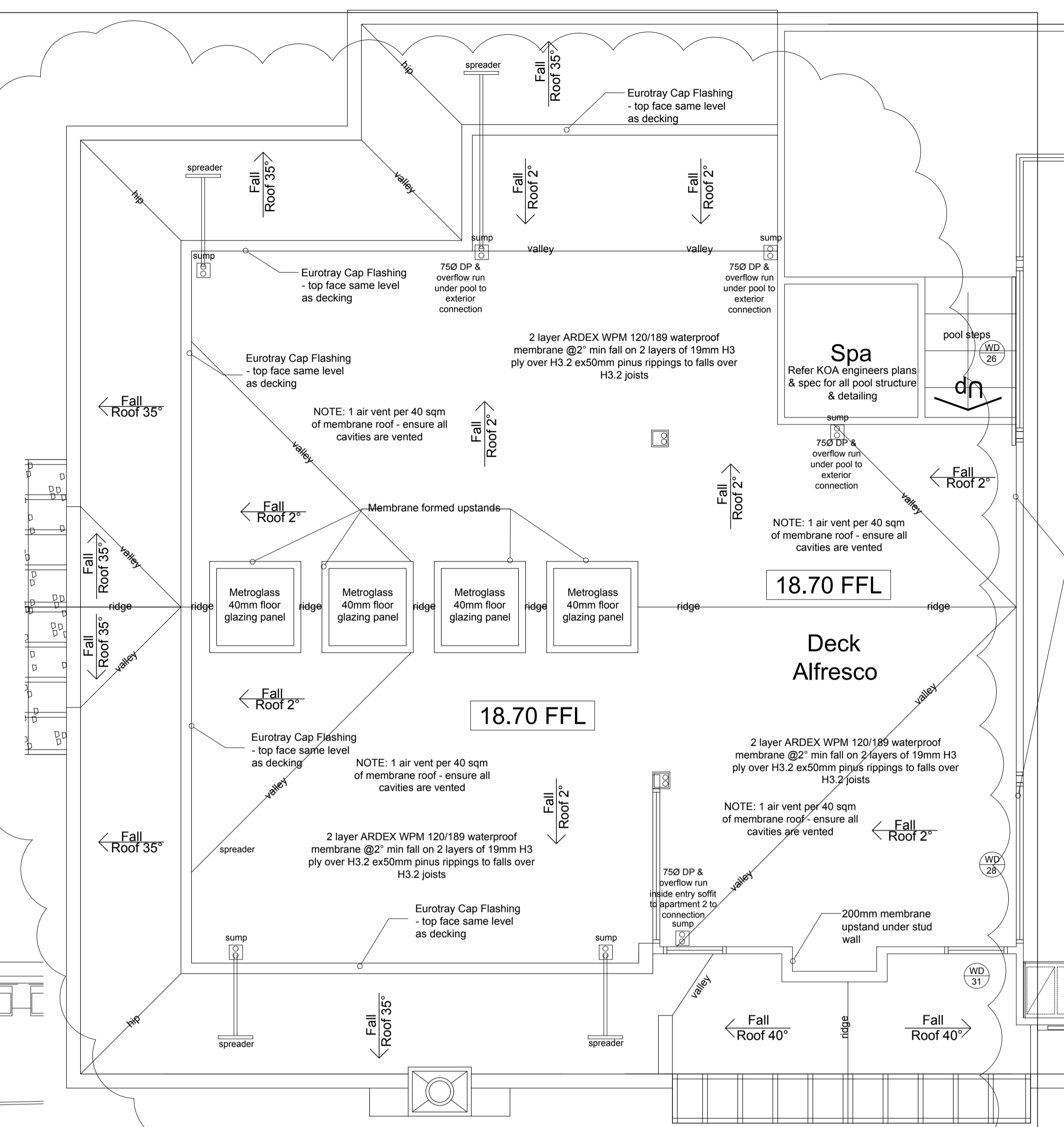

Revisions	General notes

NOTE:  
**AMENDMENT**  
**09/18**

59 ROSEBERRY AVE. BIRKENHEAD AUCKLAND TEL (09)418 2432 FAX (09)419 5142  
**APARTMENT DEVELOPMENT**  
 81 SARDSFIELD STREET, HERNE BAY

**DECKS & PLUMBING**

Drawing Reference: SAR 020  
 Date: DEC'17  
 Scale: 1/100 @ A1  
 Clad ref: SAR  
 CADREF

**DELAMARE ARCHITECTS**

USE FIGURED DIMENSIONS. DO NOT SCALE FROM DRAWING. ALL LEVELS AND DIMENSIONS TO BE CHECKED ON SITE. DRAWING TO BE READ IN CONJUNCTION WITH ALL RELEVANT DOCUMENTS. © THE COPYRIGHT OF THIS DRAWING IS THE PROPERTY OF DAVID DELAMARE.

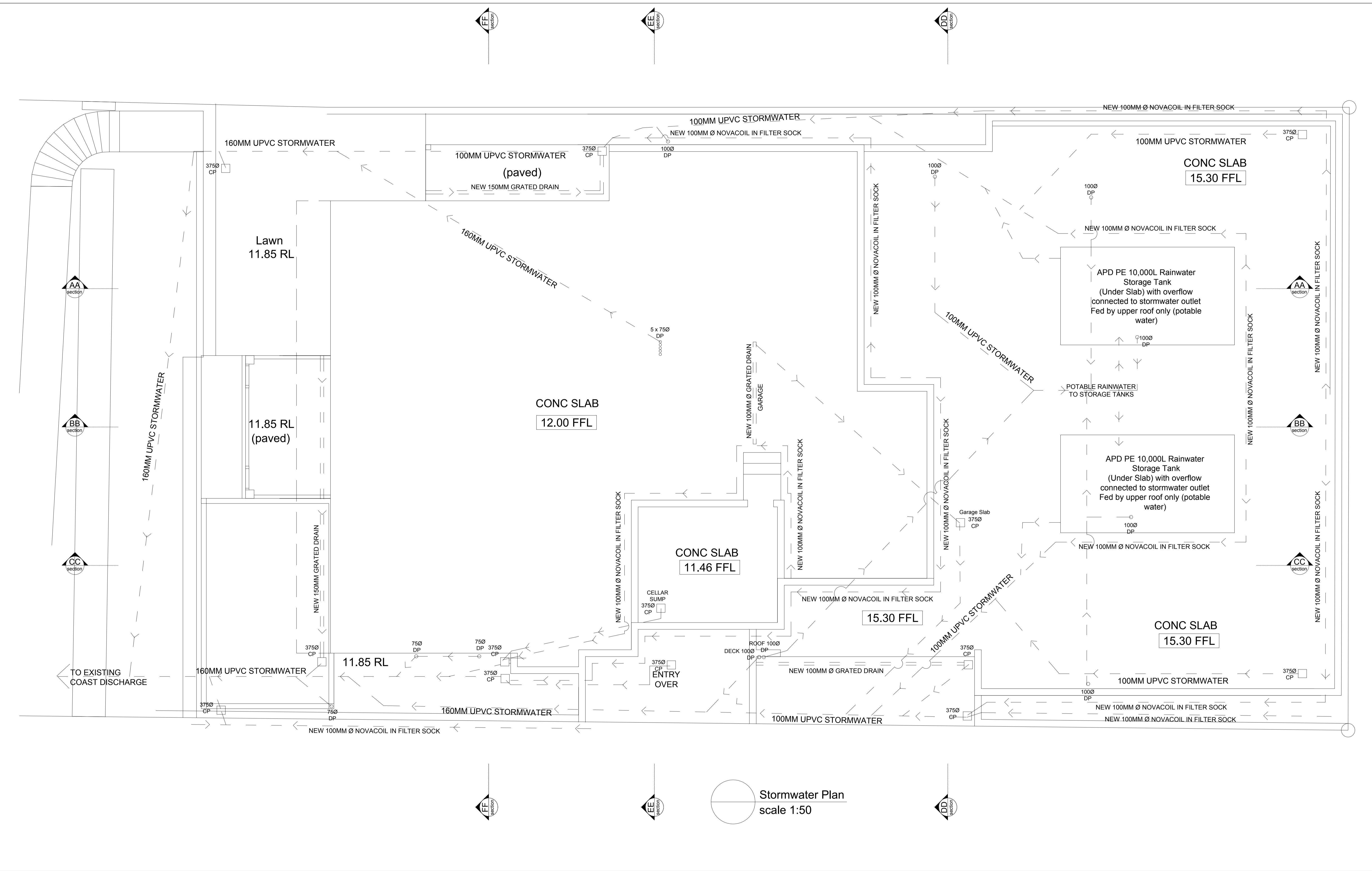

Stormwater Plan  
scale 1:50

Revisions	General notes

NOTE:  
**STAGE 2  
CONSENT**

59 ROSEBERRY AVE BIRKENHEAD AUCKLAND TEL (09)418 2432 FAX (09)419 5142  
 APARTMENT DEVELOPMENT  
 81 SANSFIELD STREET, HERNE BAY

**DELAMARE ARCHITECTS**

Date DEC'17  
 Scale 1/50 @ A1  
 Drawing Reference  
 Job no SAR 021  
 Revision  
 Cad ref SAR  
 CADREF

USE FIGURED DIMENSIONS. DO NOT SCALE FROM DRAWING.  
 ALL LEVELS AND DIMENSIONS TO BE CHECKED ON SITE.  
 DRAWING TO BE READ IN CONJUNCTION WITH ALL  
 RELEVANT DOCUMENTS.  
 ©THE COPYRIGHT OF THIS DRAWING IS THE PROPERTY  
 OF DAVID DELAMARE

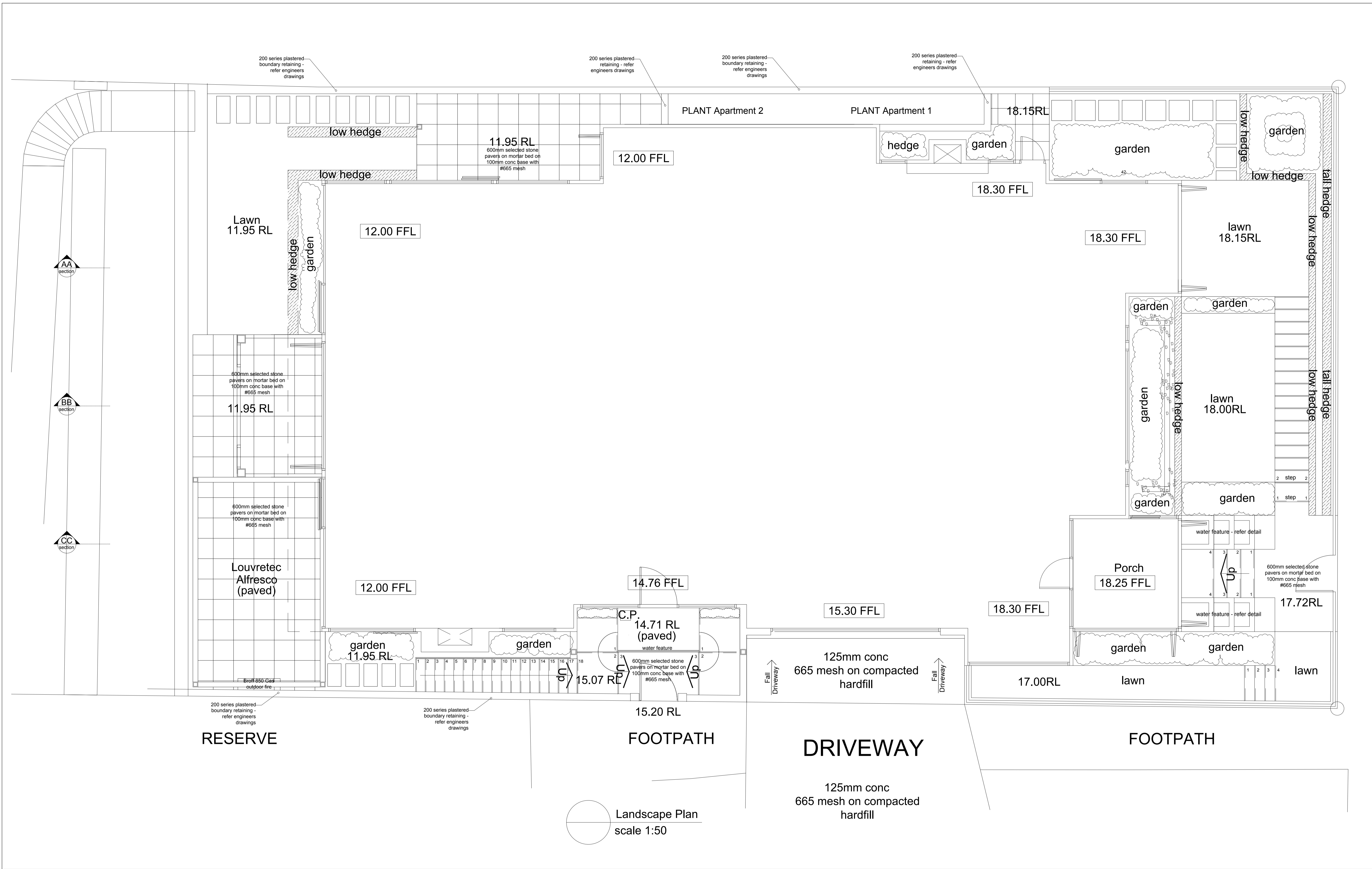

Revisions	General notes

NOTE:  
**STAGE 2  
 CONSENT**

59 ROSEBERRY AVE BIRKENHEAD AUCKLAND TEL (09)418 2432 FAX (09)419 5142		Date DEC'17	
APARTMENT DEVELOPMENT		Scale 1/50 @ A1	
81 SANSFIELD STREET, HERNE BAY		Cod ref SAR	
Drawing Reference	job no	dep no	revision
SAR	022		
LANDSCAPE		CADREF	

**DELAMARE ARCHITECTS**  
USE POURED DIMENSIONS. DO NOT SCALE FROM DRAWING. ALL LEVELS AND DIMENSIONS TO BE CHECKED ON SITE. DRAWING TO BE READ IN CONJUNCTION WITH ALL RELEVANT DOCUMENTS. © THE CONTENT OF THIS DRAWING IS THE PROPERTY OF DAVID DELAMARE.

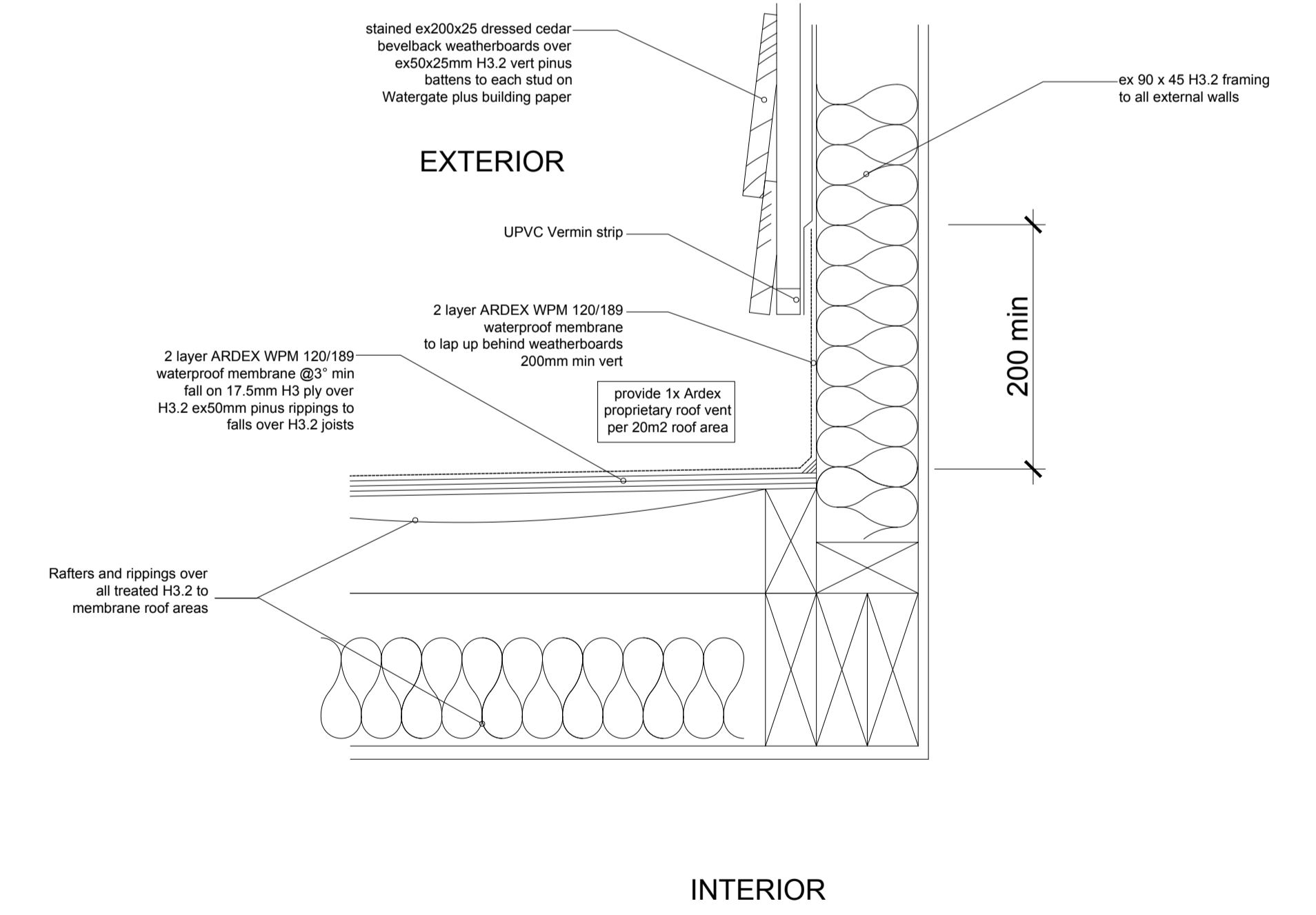
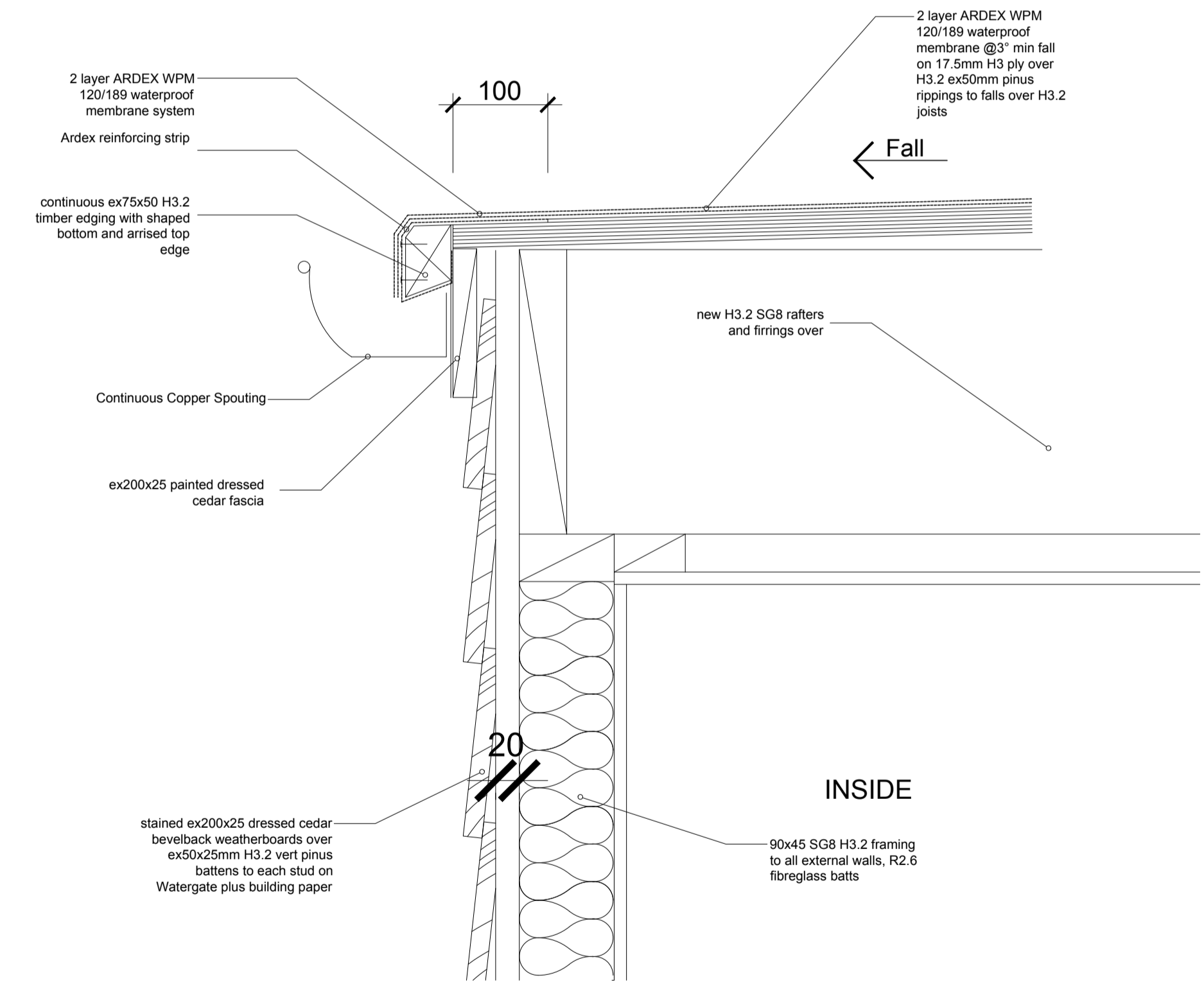
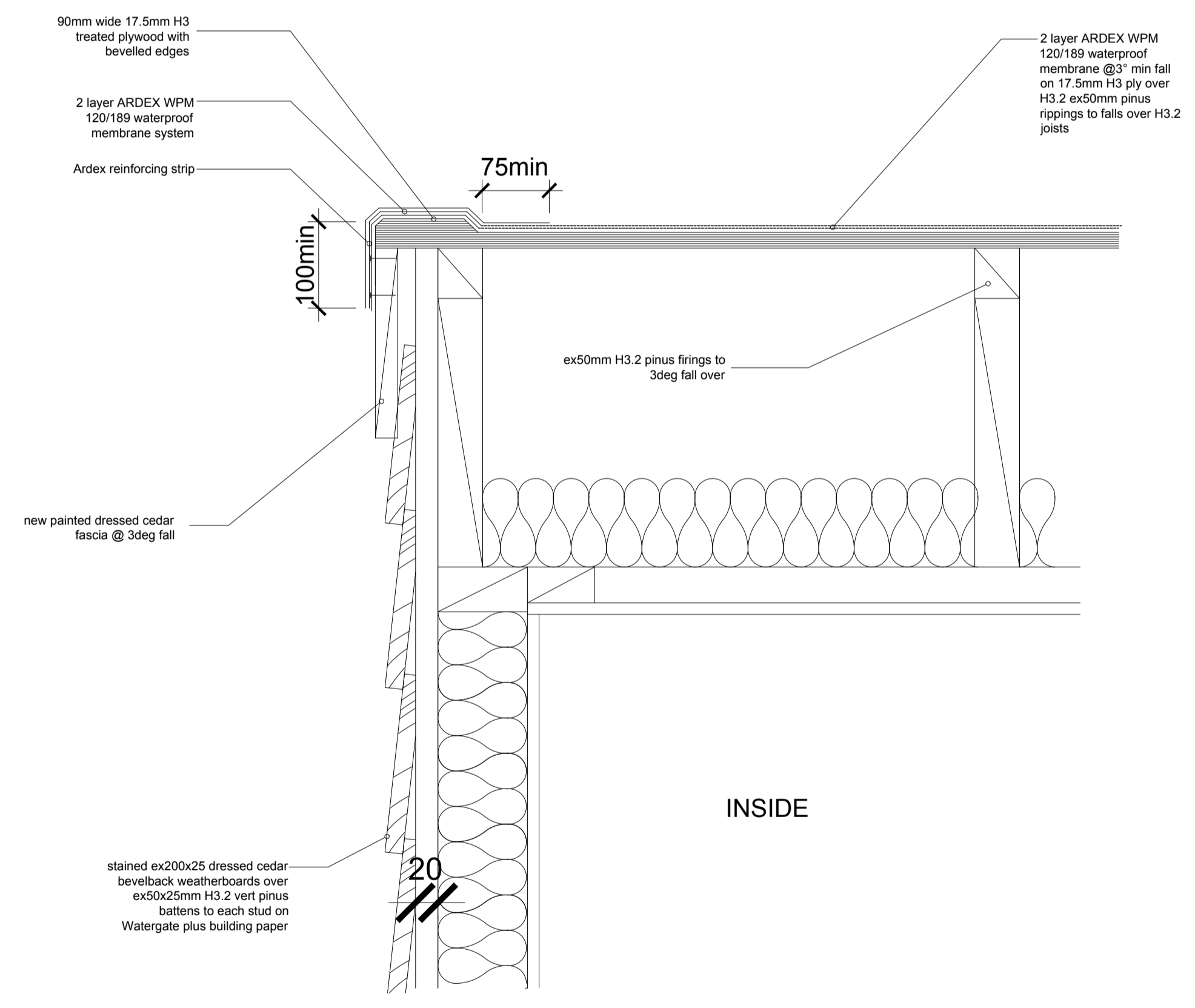
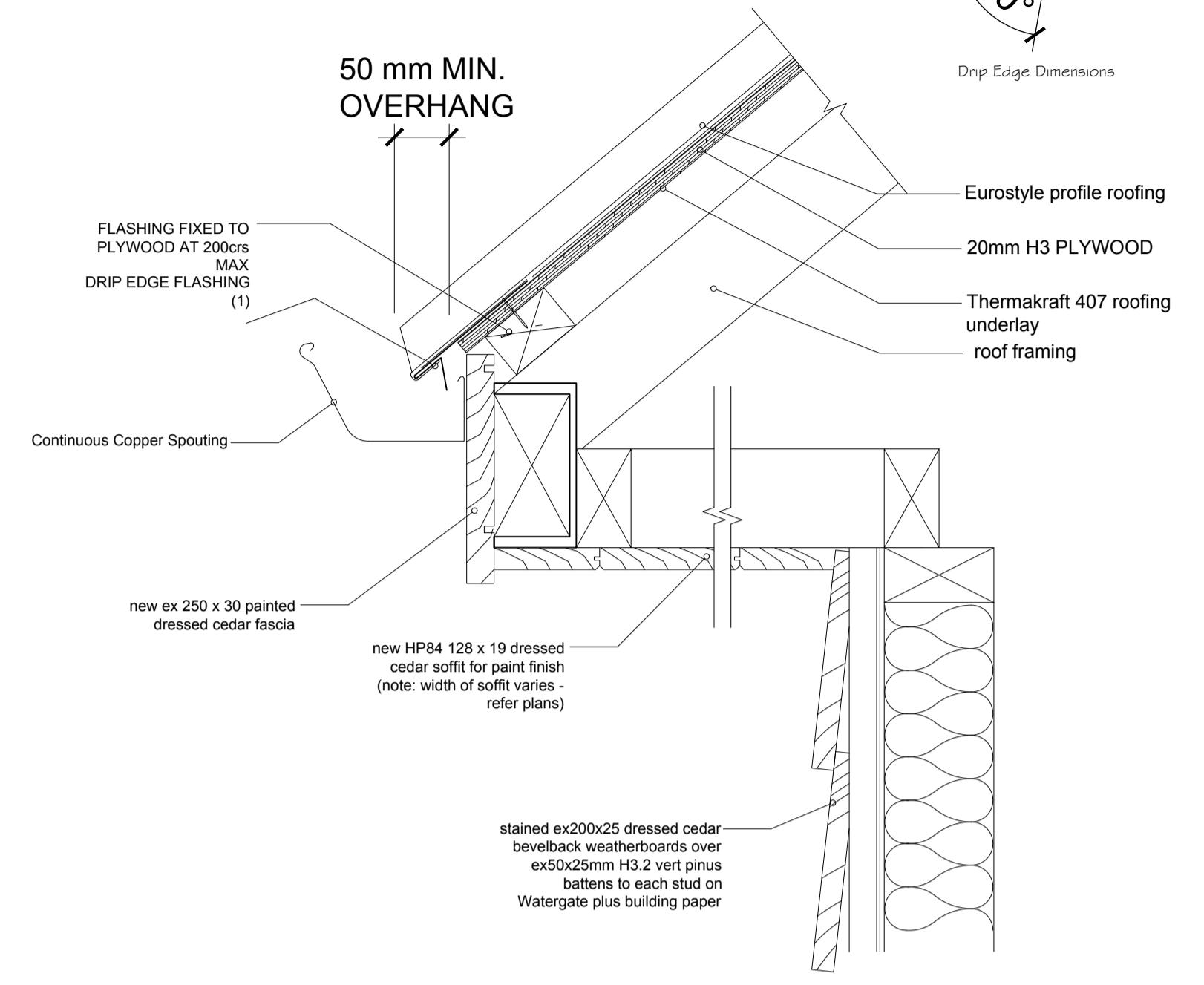
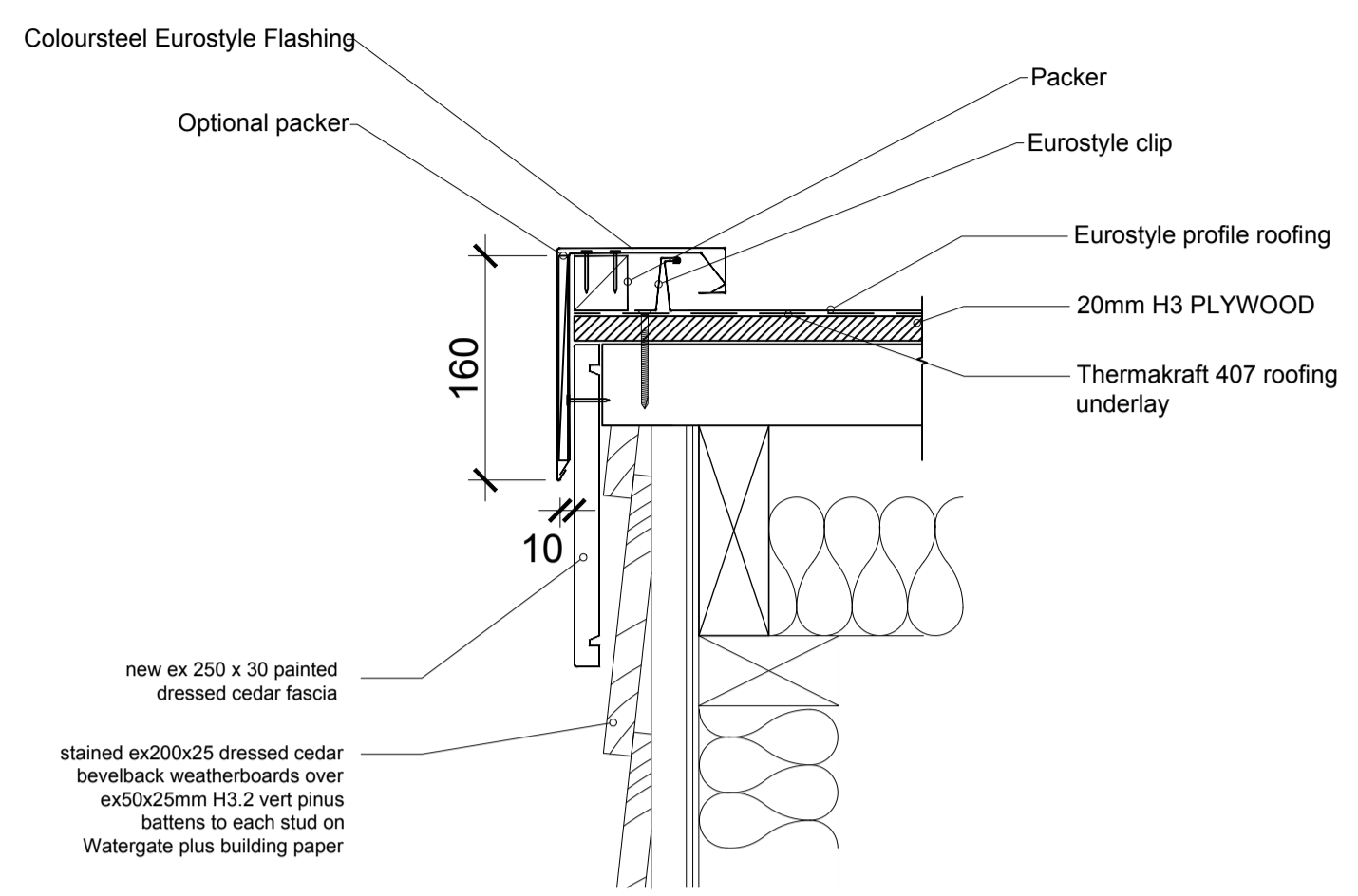
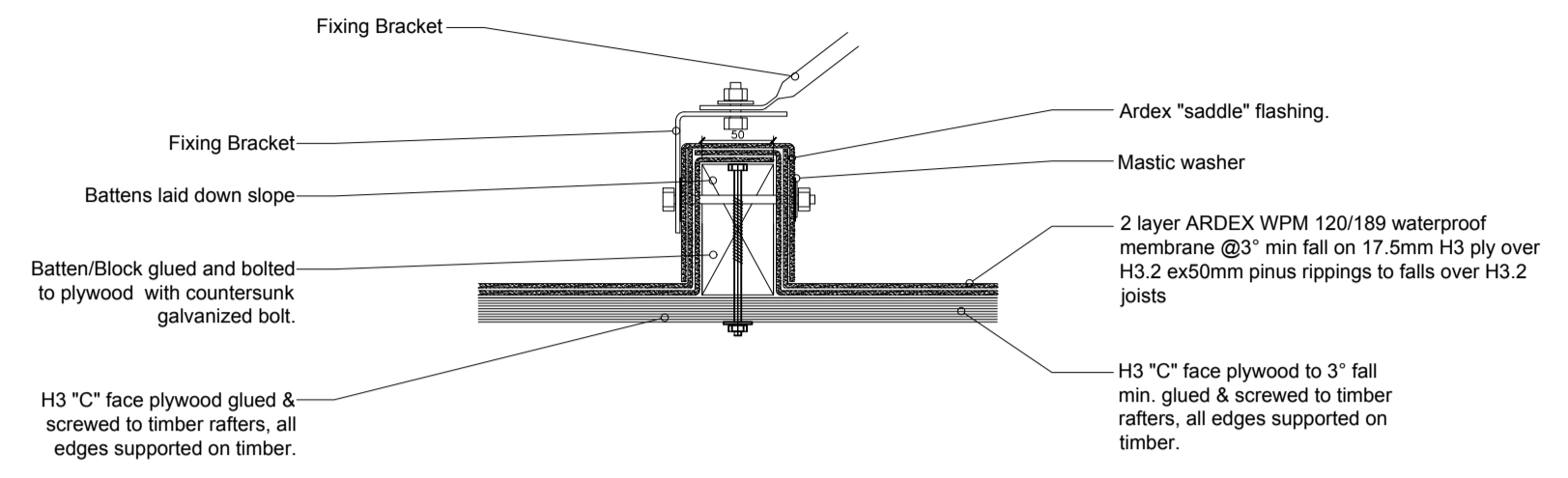
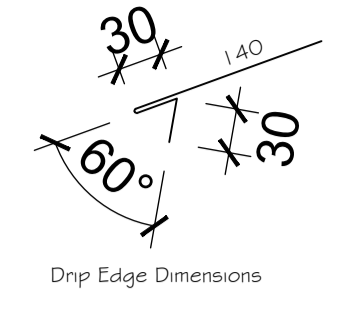

Revisions	General notes

NOTE:  
**STAGE 2  
CONSENT**

59 ROSEBERRY AVE BIRKENHEAD AUCKLAND TEL (09)418 2432 FAX (09)419 5142  
 APARTMENT DEVELOPMENT  
 81 SARSFIELD STREET, HERNE BAY

**DELAMARE ARCHITECTS**

Date DEC'17  
 Scale 1/5 @ A1  
 Drawing Reference  
 Job no SAR 023  
 Revision  
 Cod ref SAR  
 CADREF

USE FIGURED DIMENSIONS. DO NOT SCALE FROM DRAWING. ALL LEVELS AND DIMENSIONS TO BE CHECKED ON SITE. DRAWING TO BE READ IN CONJUNCTION WITH ALL RELEVANT DOCUMENTS. ©THE COPYRIGHT OF THIS DRAWING IS THE PROPERTY OF DAVID DELAMARE

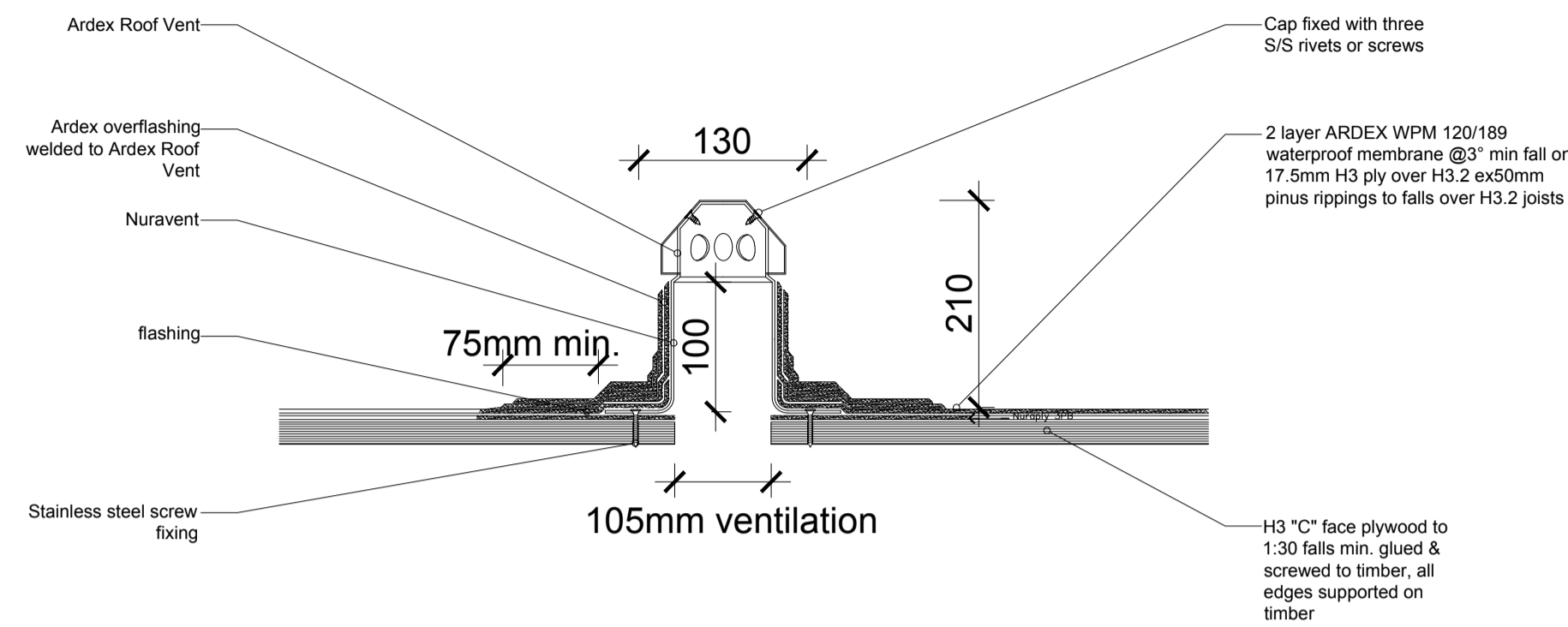

**07** Membrane Vent Detail  
024 scale 1:5

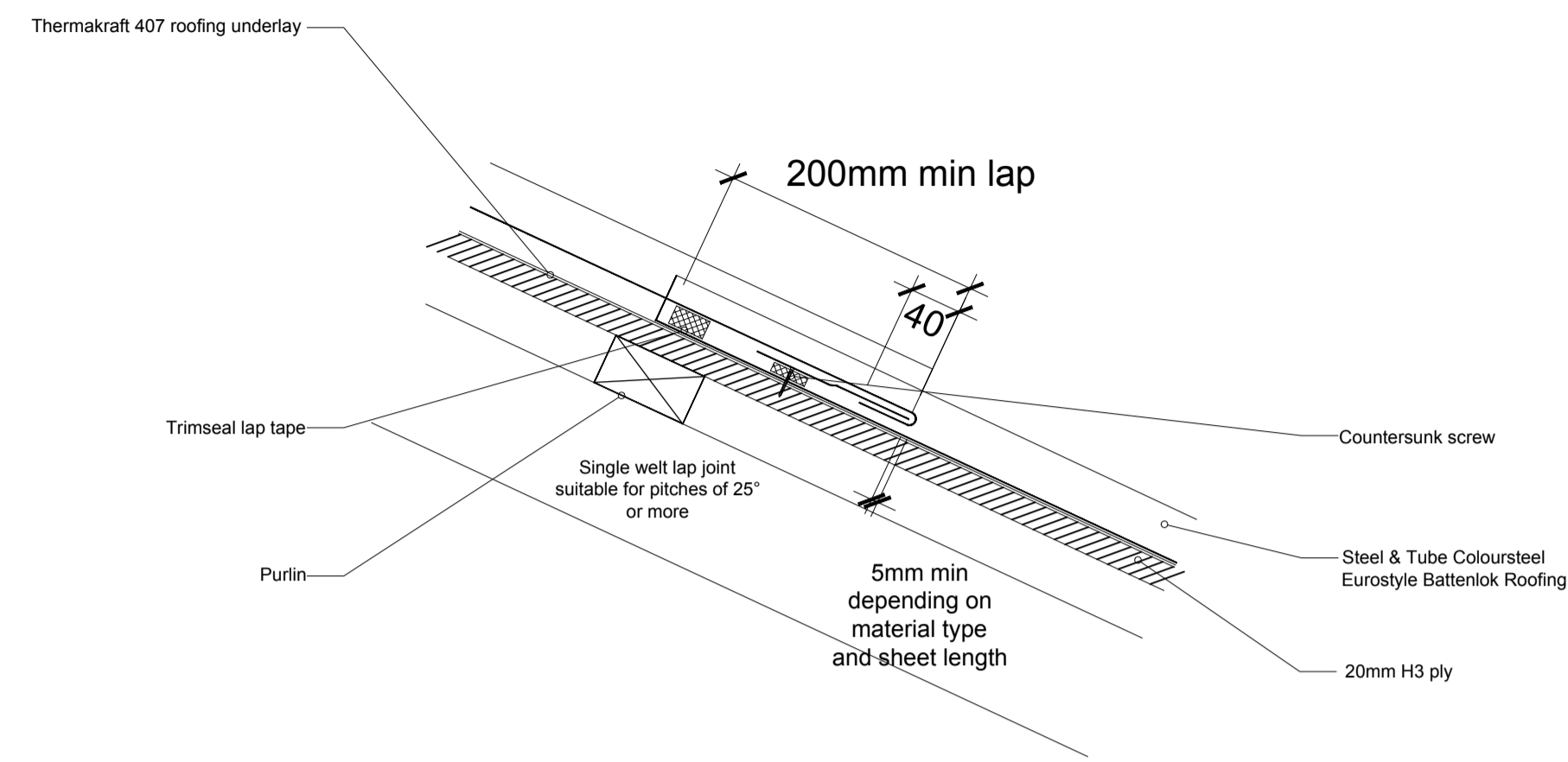

**08** Expansion Joint Detail  
024 scale 1:5

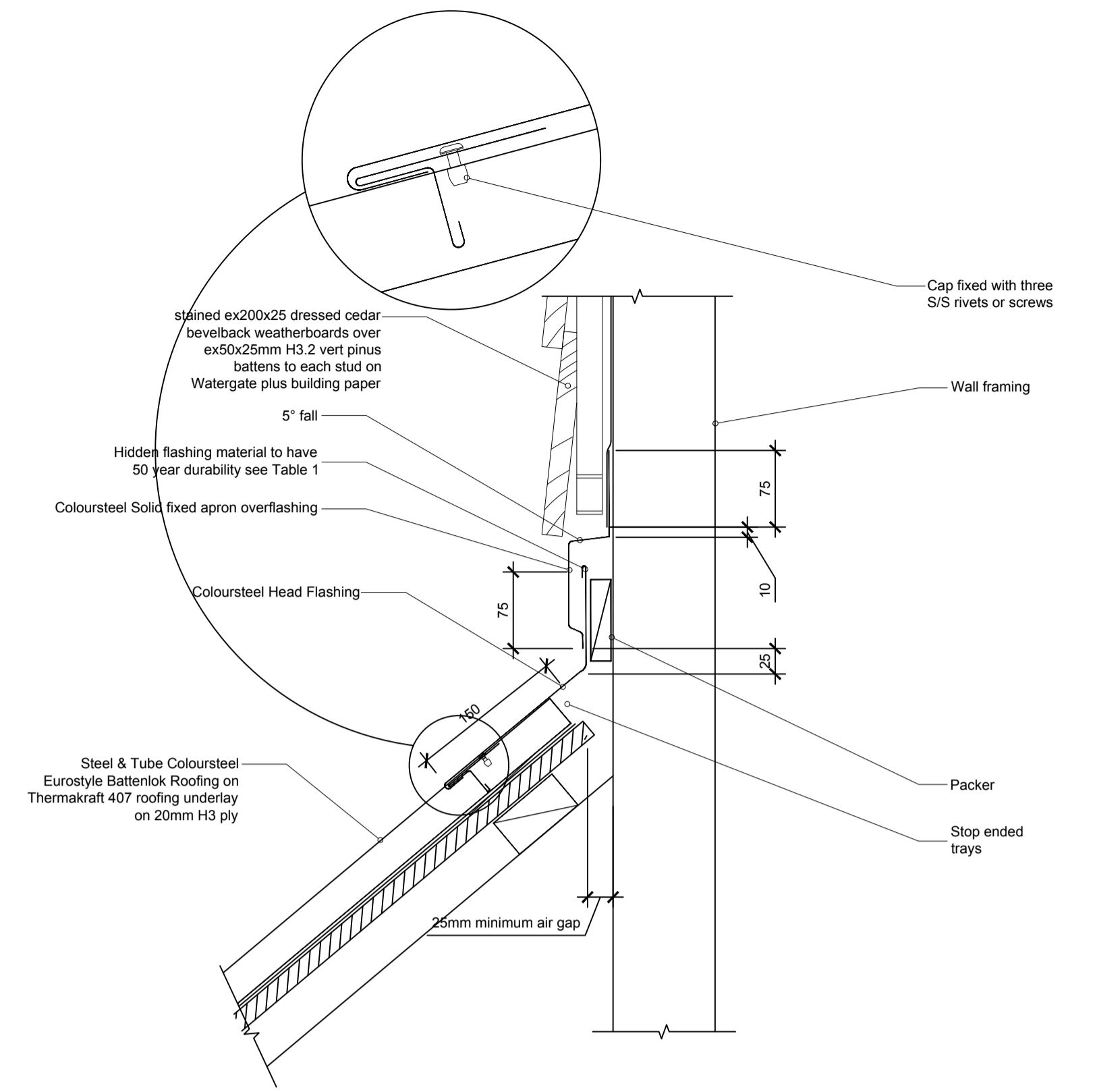

Note:  
1. Rivet head flashing onto cap, angle seam or roll seam.  
2. For installation of ply refer to Ecoply: Structural Plywood Properties and Applications Manual available from www.ecoply.co.nz

**09** Apron Flashing Detail  
024 scale 1:5

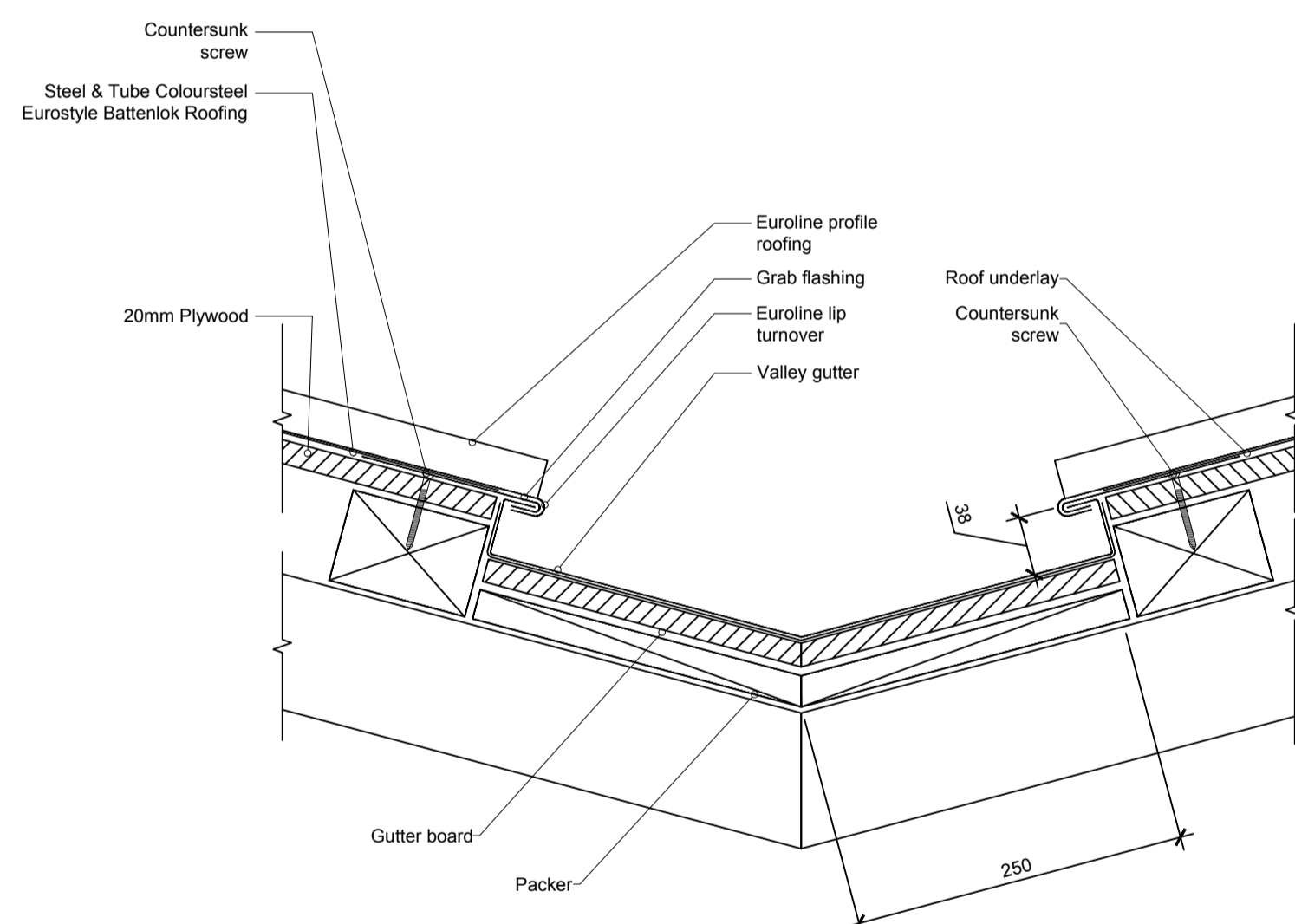

Valley Angle Table

Roof Pitch	5	10	15	20	25	30	35	45	60
Valley Angle X°	173	166	159	152	145	139	132	120	104

\* Dimensions suitable for 25m<sup>2</sup> catchment at 12°. For larger catchments or lower pitches design as for internal gutter.

**10** Valley Detail  
024 scale 1:5

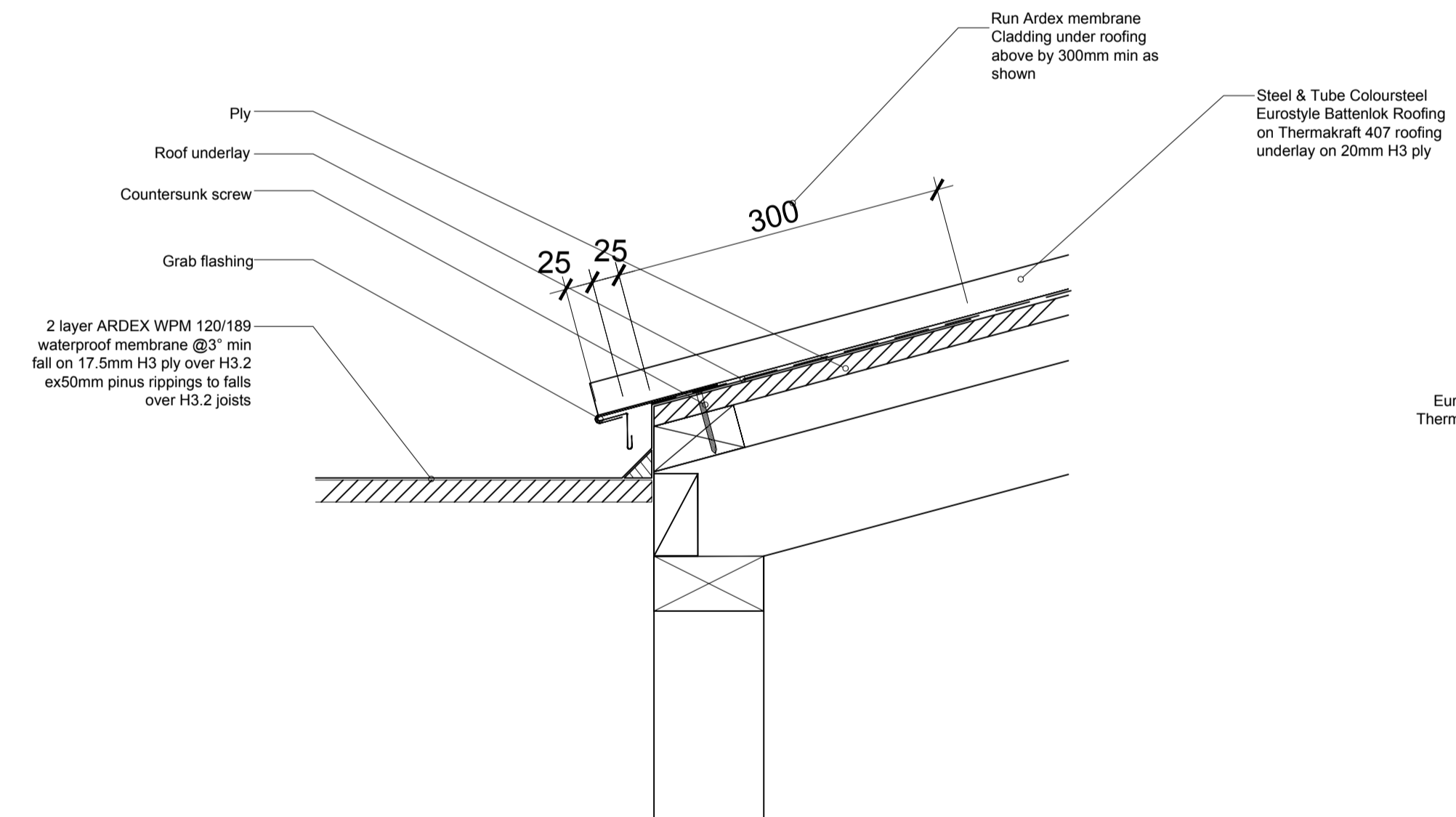

**11** Roof Cladding Junction Detail  
024 scale 1:5

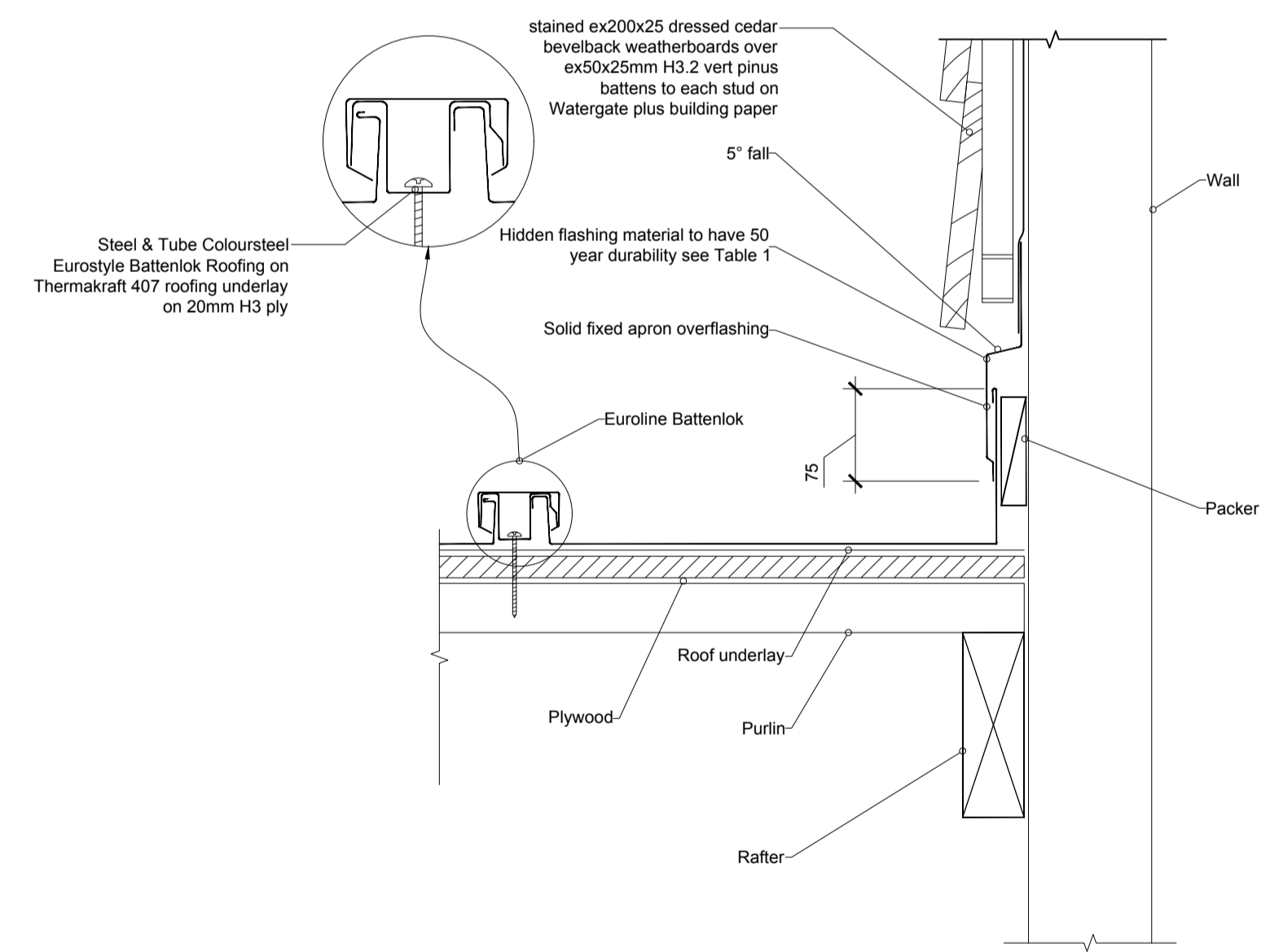

**12** Parallel Apron Flashing Detail  
024 scale 1:5

Revisions	General notes

NOTE:  
**STAGE 2  
CONSENT**

59 ROSEBERRY AVE BIRKENHEAD AUCKLAND TEL (09)418 2432 FAX (09)419 5142  
 APARTMENT DEVELOPMENT  
 81 SANSFIELD STREET, HERNE BAY

**DELAMARE ARCHITECTS**

Date: DEC'17  
 Scale: 1/5 @ A1  
 Drawing Reference: SAR 024  
 Job no: SAR 024  
 Revision: CADREF  
 Cod ref: SAR  
 © THE COPYRIGHT OF THIS DRAWING IS THE PROPERTY OF DAVID DELAMARE

USE DIMENSIONS TO BE CHECKED ON SITE. DRAWING TO BE READ IN CONJUNCTION WITH ALL RELEVANT DOCUMENTS.



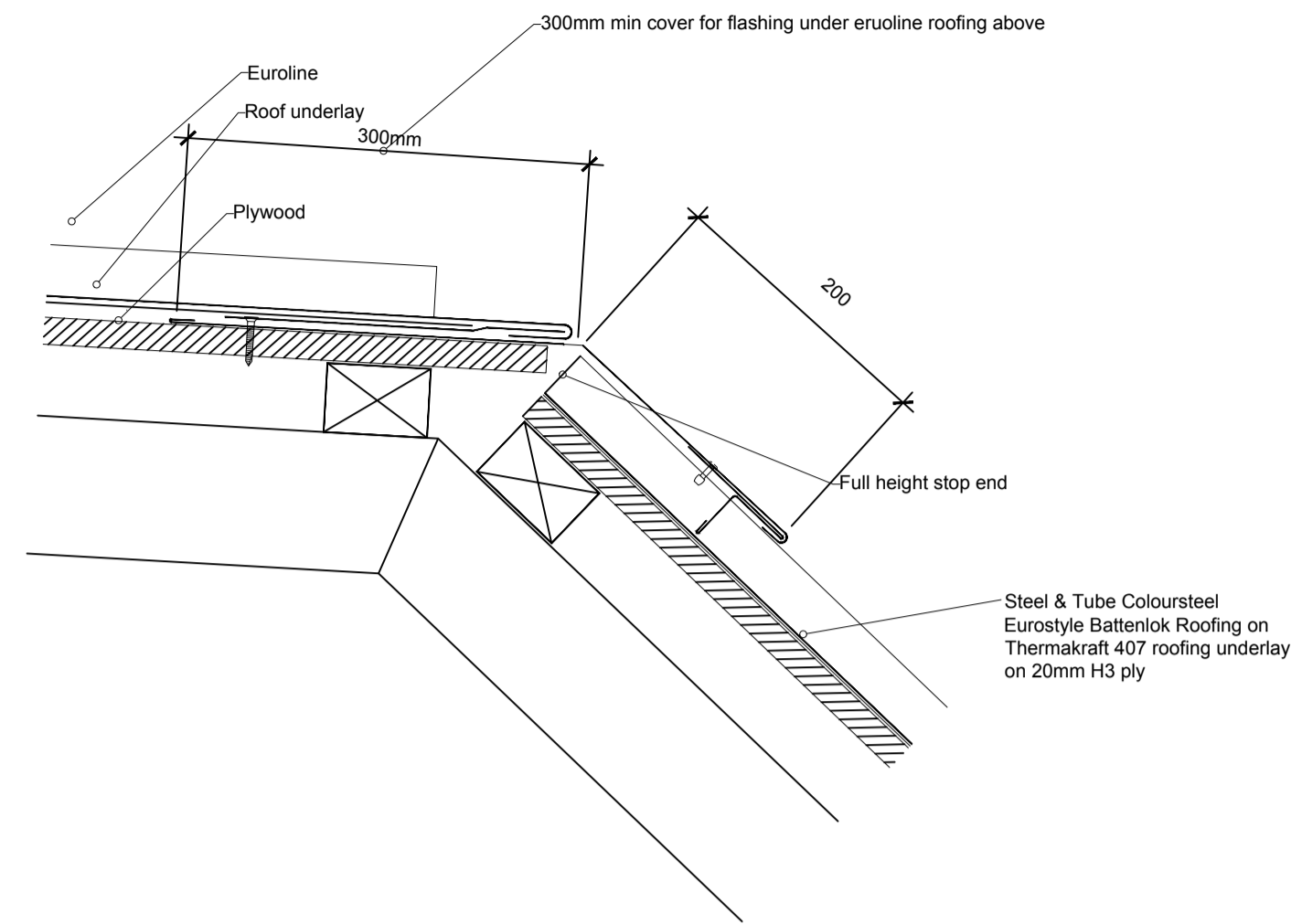

**13** Change Of Pitch  
025 scale 1:5

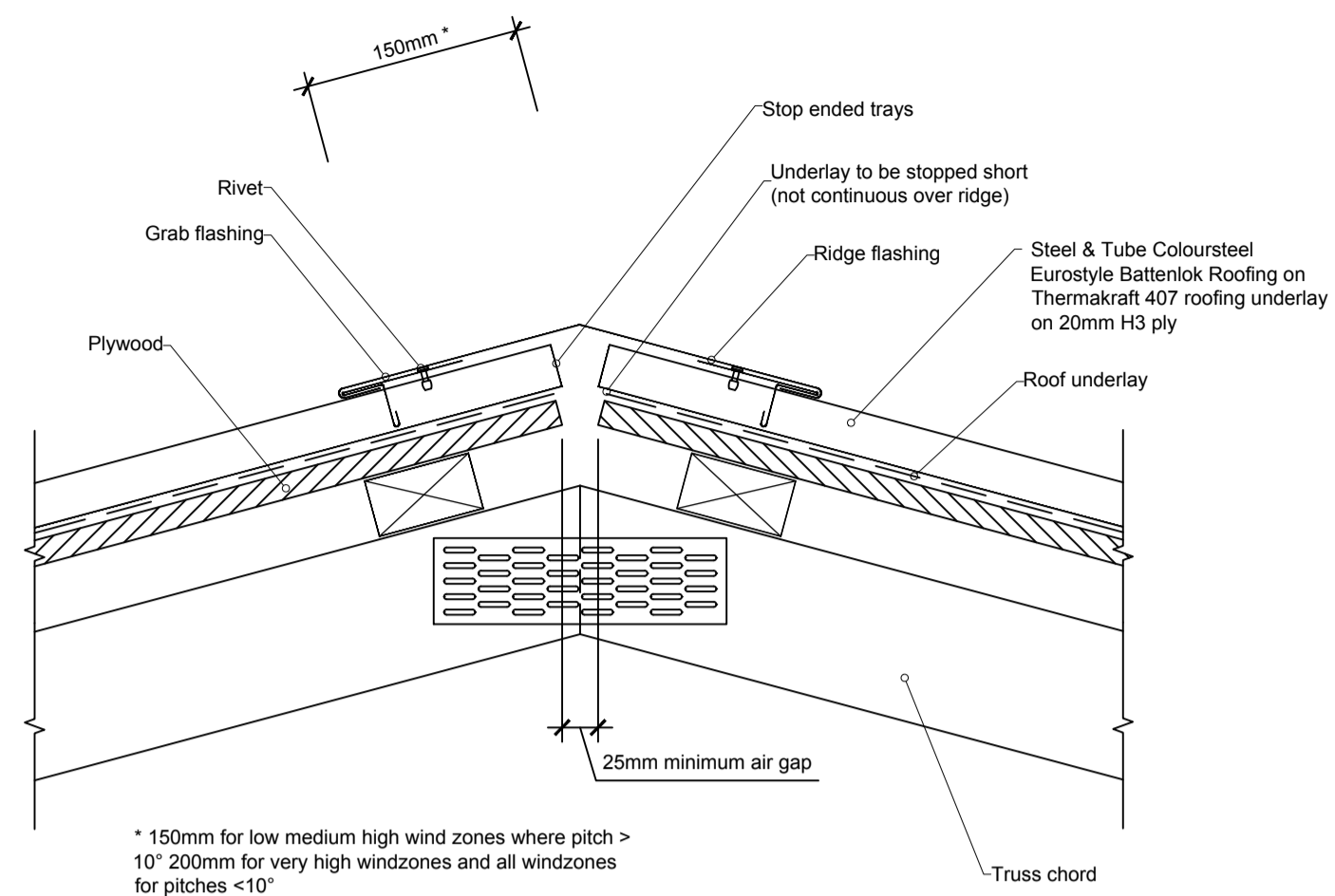

\* 150mm for low medium high wind zones where pitch > 10° 200mm for very high windzones and all windzones for pitches <10°

Note:  
For installation of ply refer to ecoply: Structural Plywood Properties and Applications Manual available from www.ecoply.co.nz

**14** Ridge Detail  
025 scale 1:5

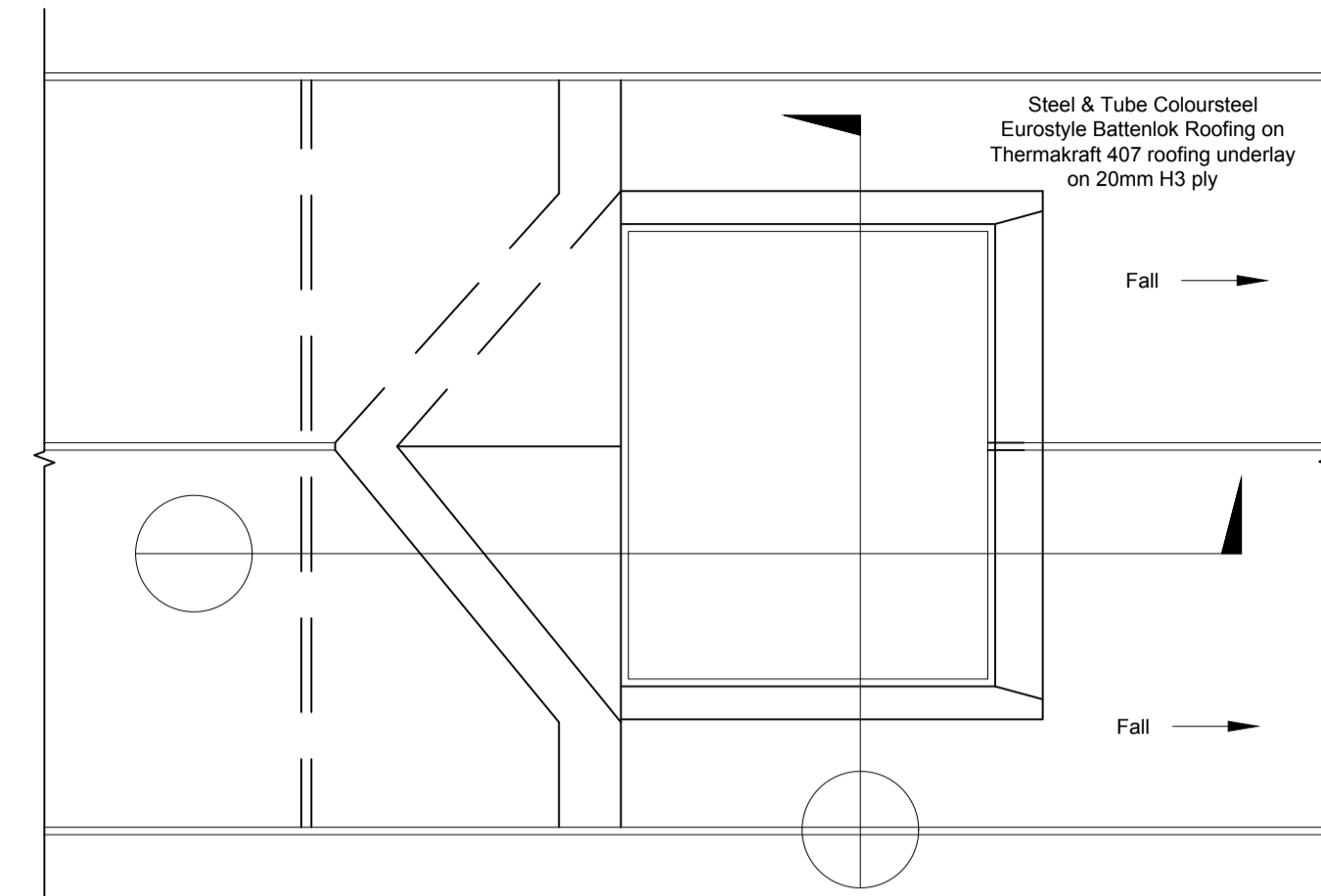

**15** Chimney Cricket flashing (plan)  
025 scale 1:5

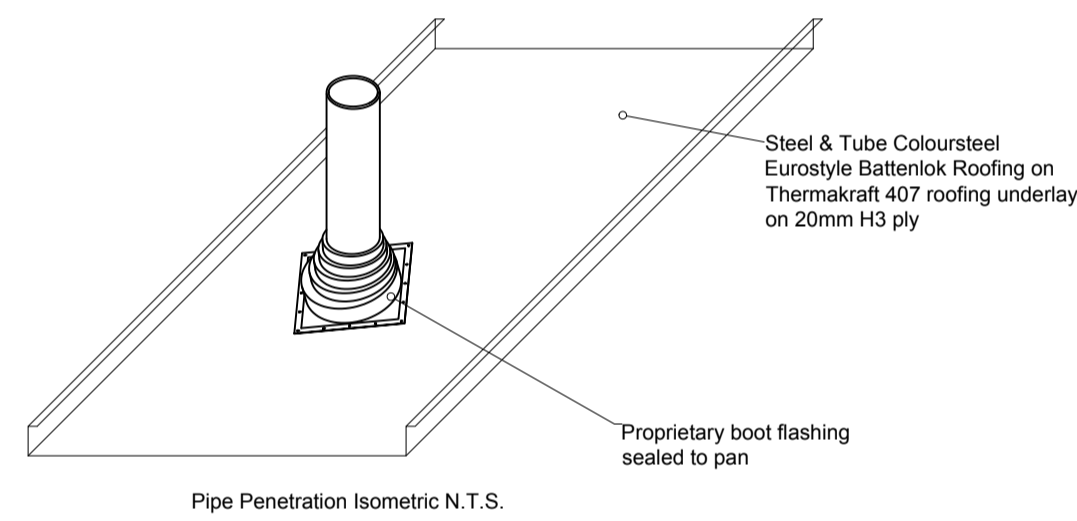

Pipe Penetration Isometric N.T.S.

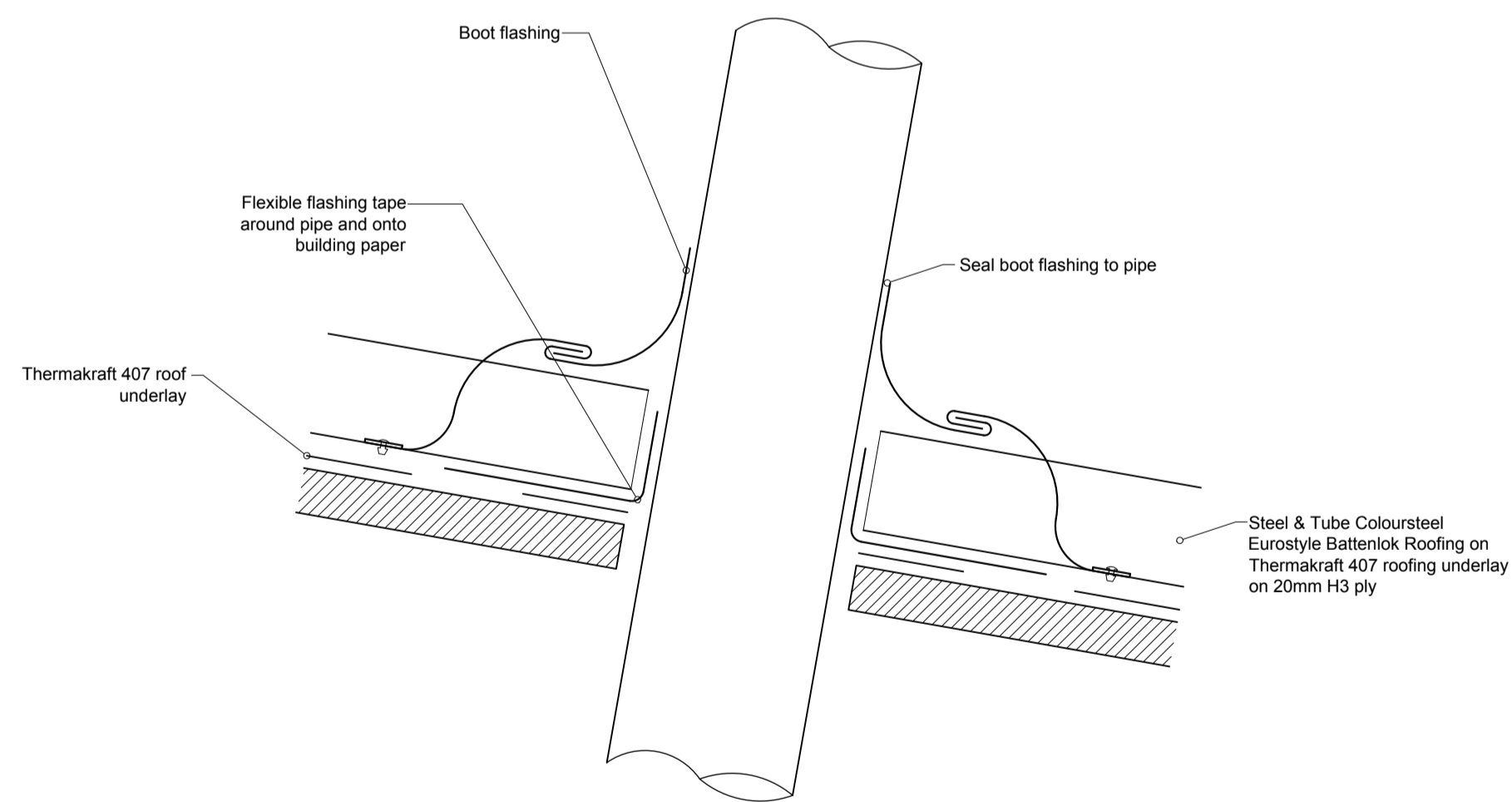

**16** Pipe Penetration Detail  
025 scale 1:5

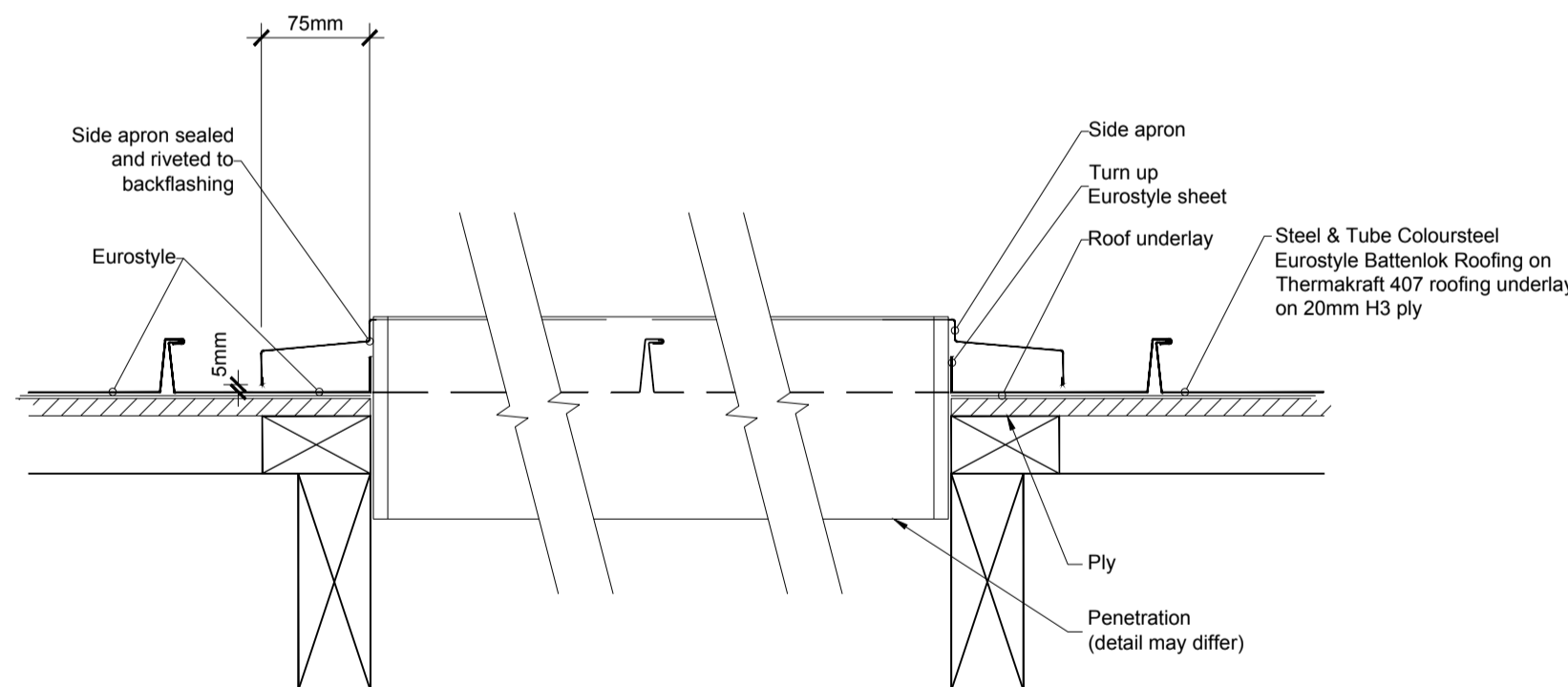

**17** Chimney flashing section  
025 scale 1:5

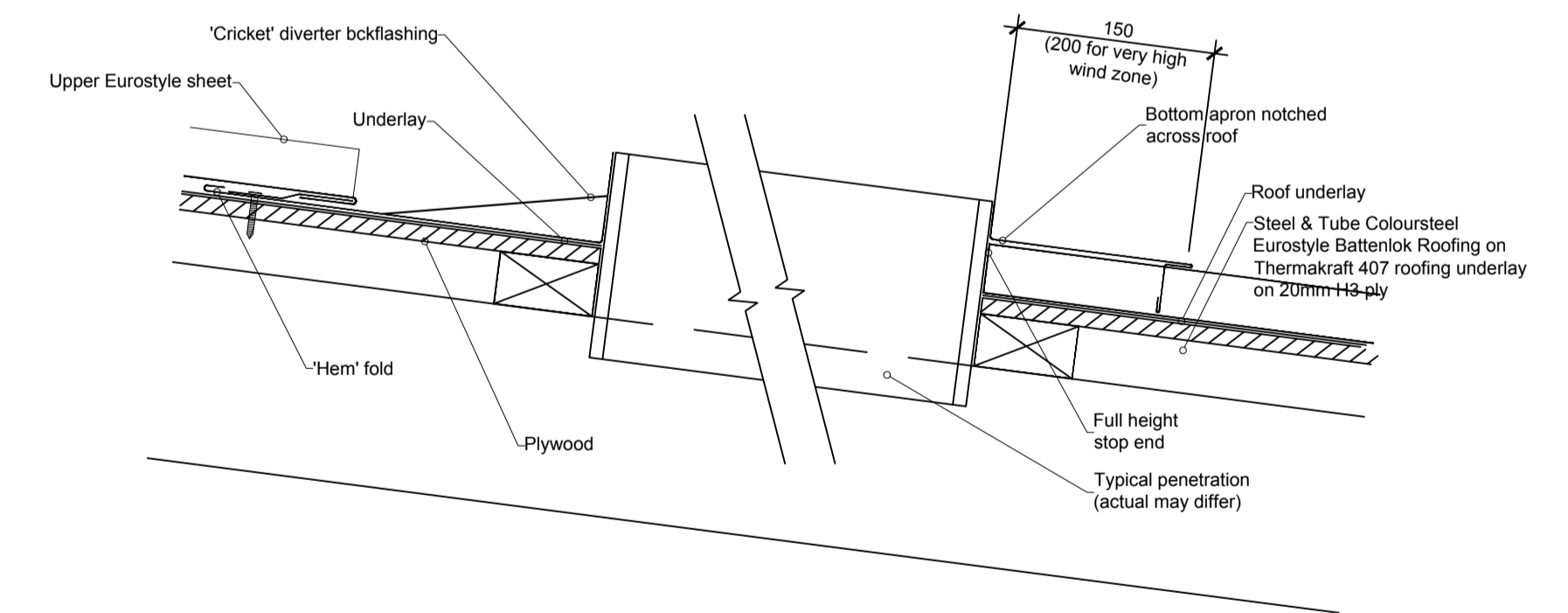

**18** Chimney flashing cross section  
025 scale 1:5

Revisions	General notes

NOTE:

**STAGE 2  
CONSENT**

59 ROSEBERRY AVE BIRKENHEAD AUCKLAND TEL (09)418 2432 FAX (09)419 5142

APARTMENT DEVELOPMENT  
81 SARSFIELD STREET, HERNE BAY

DETAILS

Drawing Reference

job no: SAR 025

Date: DEC'17

Scale: 1/5 @ A1

Cad ref: SAR

revision: CADREF

**DELAMARE  
ARCHITECTS**

USE SQUARE DIMENSIONS. DO NOT SCALE FROM DRAWING.  
ALL LEVELS AND DIMENSIONS TO BE CHECKED ON SITE.  
DRAWING TO BE READ IN CONJUNCTION WITH ALL  
RELEVANT DOCUMENTS.  
©THE COPYRIGHT OF THIS DRAWING IS THE PROPERTY  
OF DAVID DELAMARE

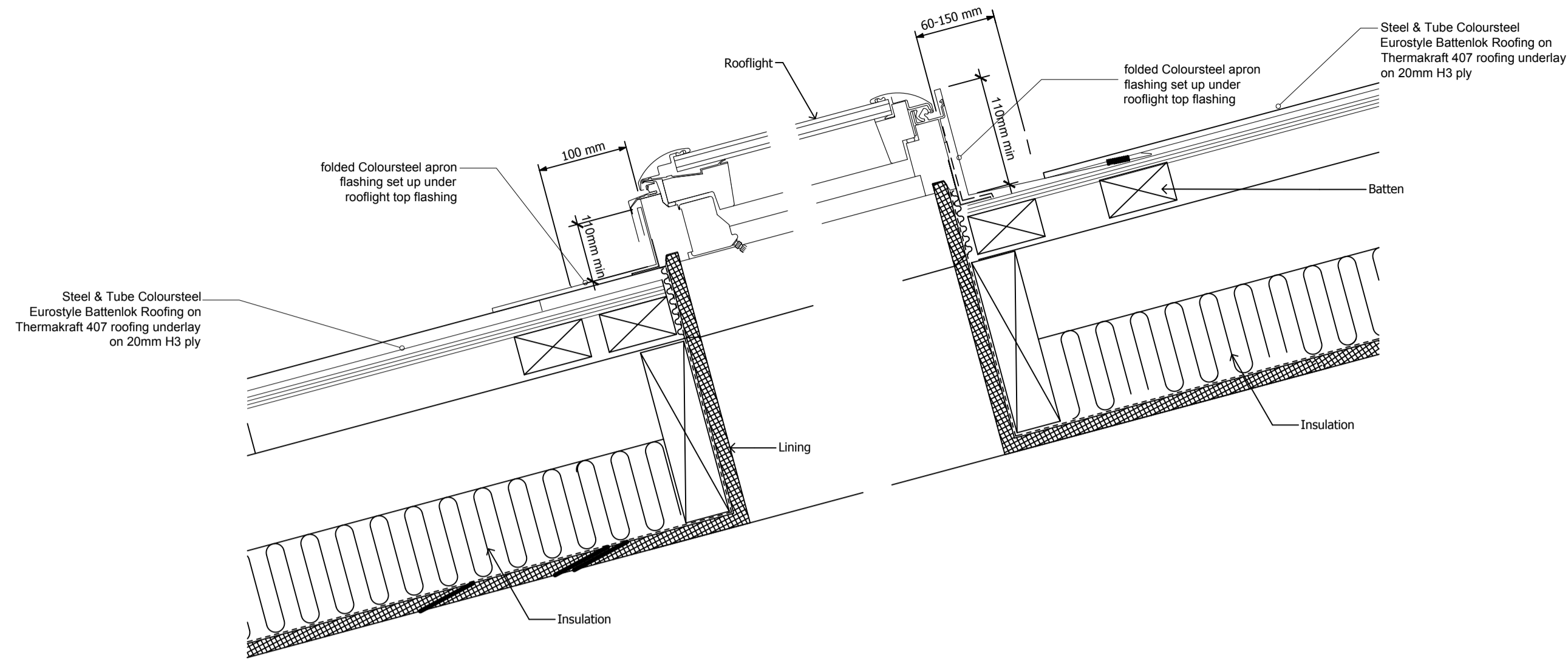

**19** Rooflight Head & Sill Details  
026 scale 1:5

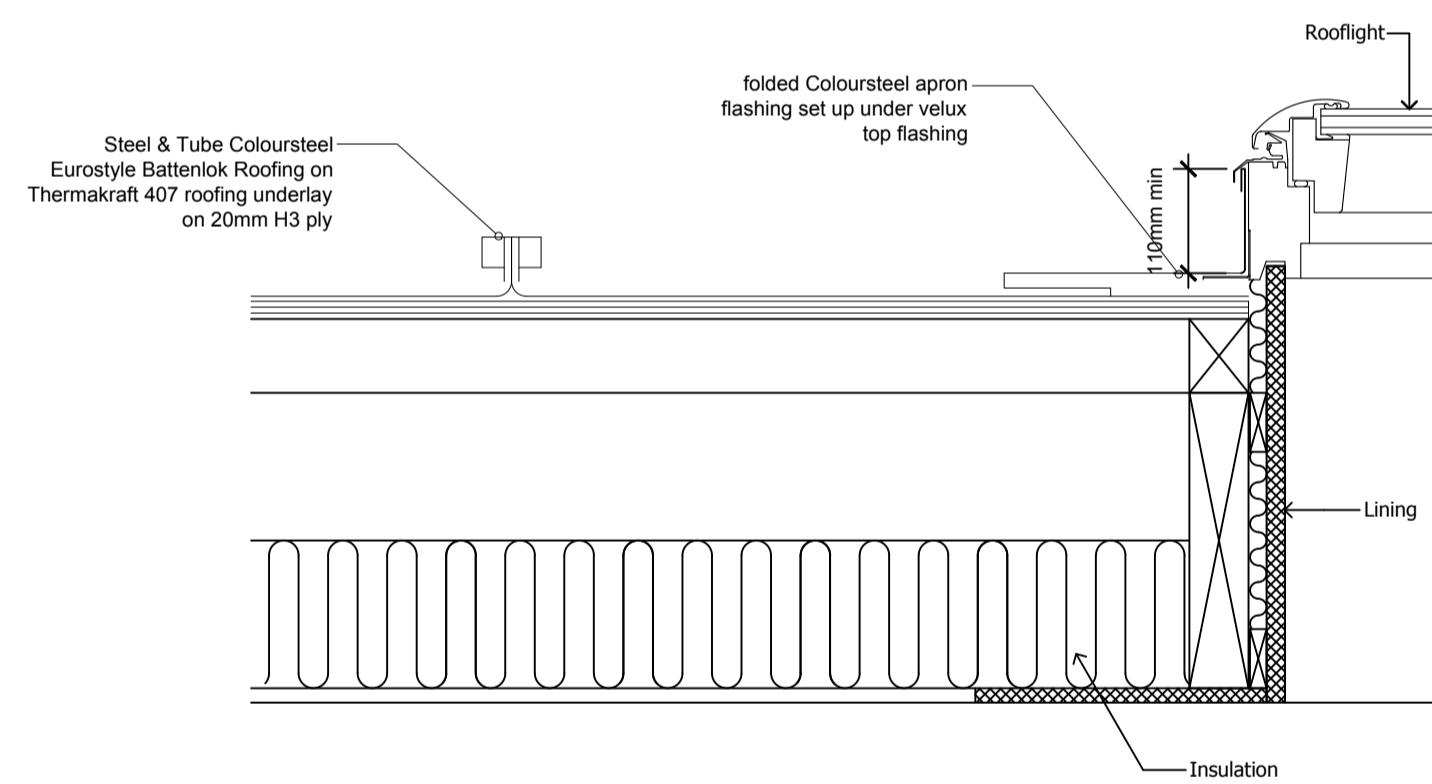

**20** Rooflight Jamb Detail  
026 scale 1:5

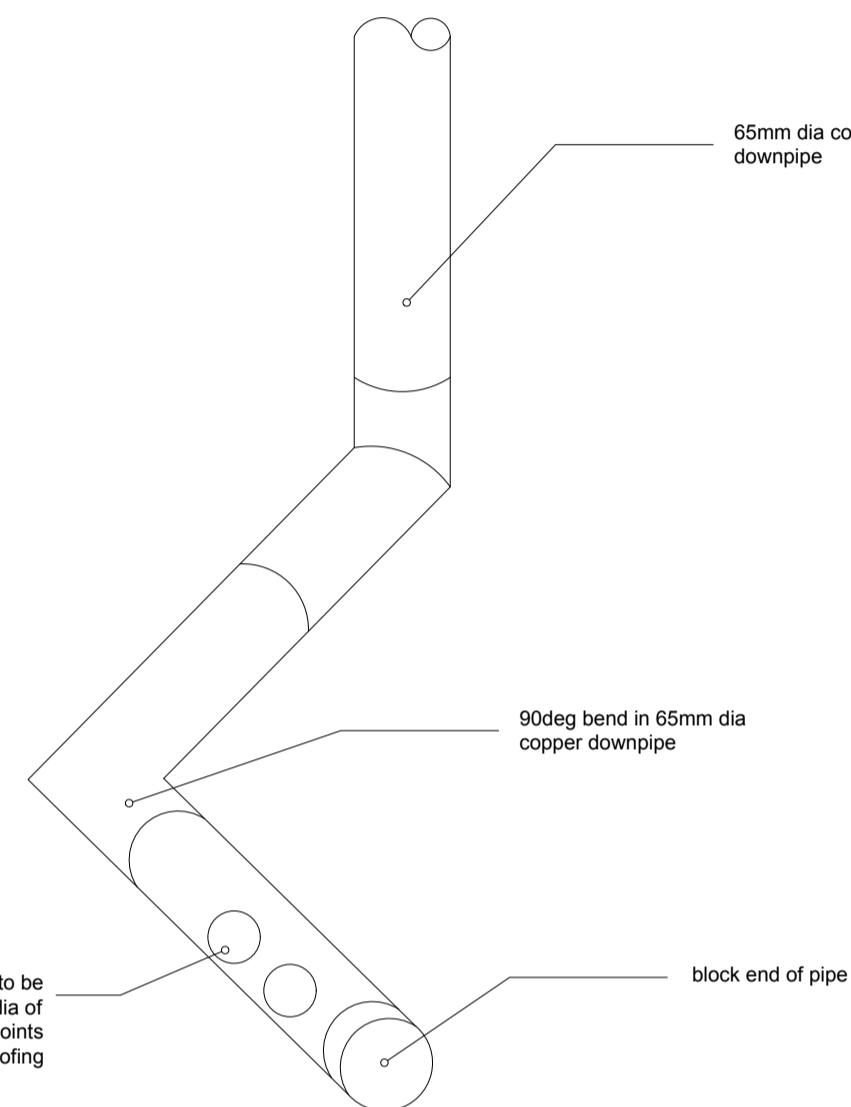

**Downpipe dropper Isometric**  
scale 1:5

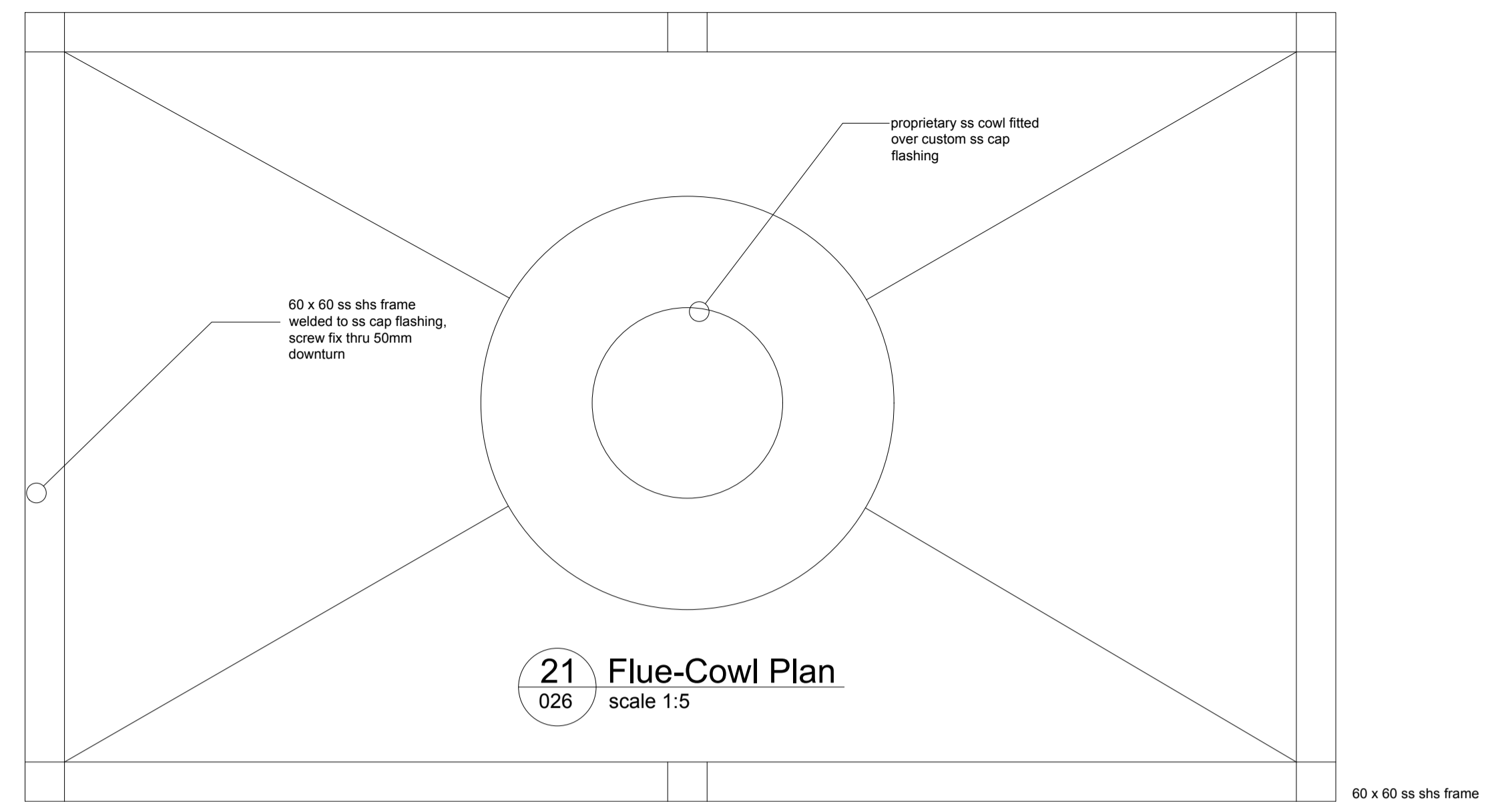

**21** Flue-Cowl Plan  
026 scale 1:5

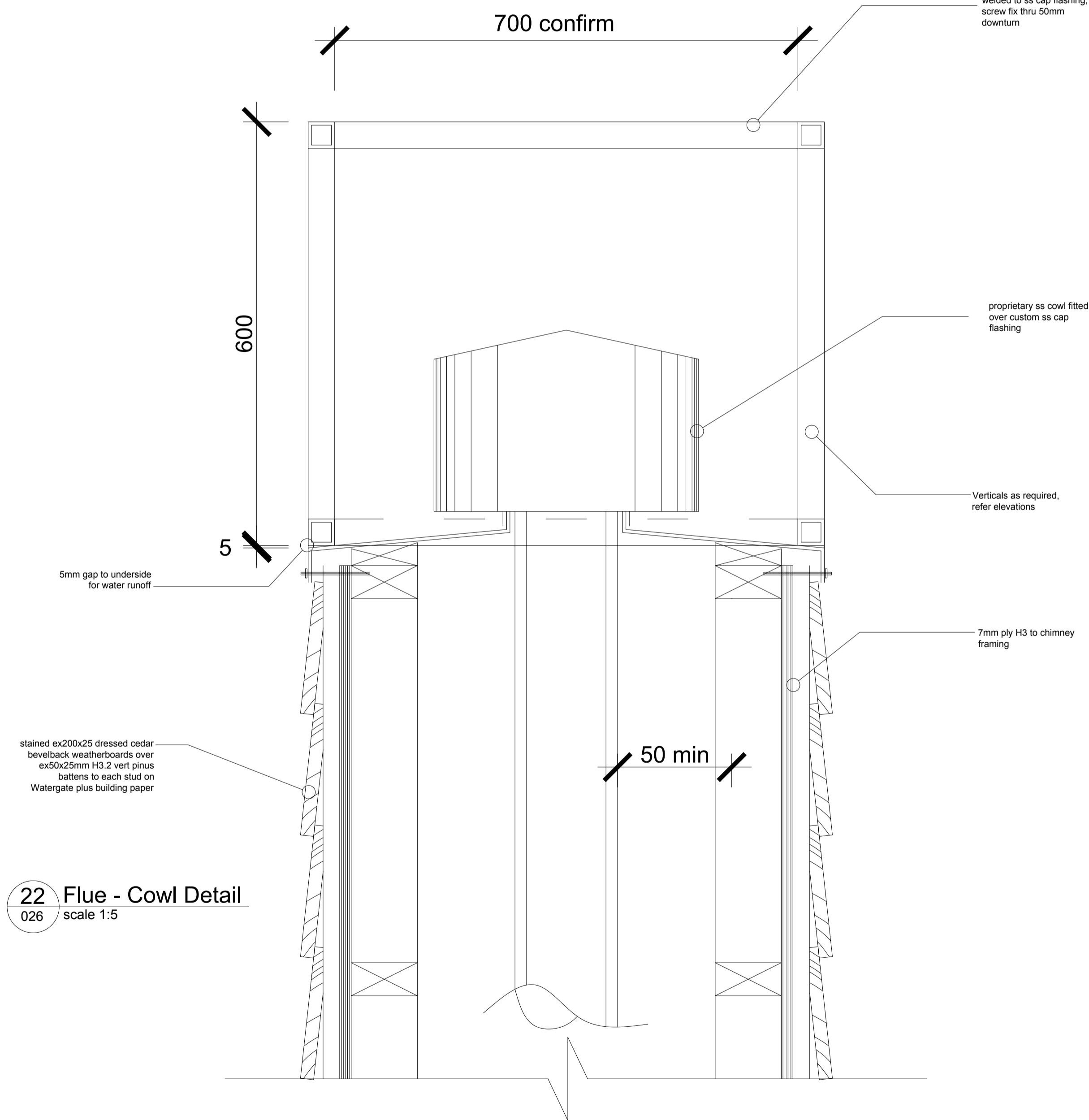

**22** Flue - Cowl Detail  
026 scale 1:5

Revisions	General notes

NOTE:

**STAGE 2  
CONSENT**

59 ROSEBERRY AVE BIRKENHEAD AUCKLAND TEL (09)418 2432 FAX (09)419 5142  
APARTMENT DEVELOPMENT  
81 SANSFIELD STREET, HERNE BAY

**DELAMARE  
ARCHITECTS**

DATE DEC'17  
SCALE 1/5 @ A1  
DRAWING REFERENCE  
JOB NO SAR 026  
REVISION  
COD REF SAR  
CADREF

USE DIMENSIONS TO BE CHECKED ON SITE.  
DRAWING TO BE READ IN CONJUNCTION WITH ALL  
RELEVANT DOCUMENTS.  
© THE COPYRIGHT OF THIS DRAWING IS THE PROPERTY  
OF DAVID DELAMARE

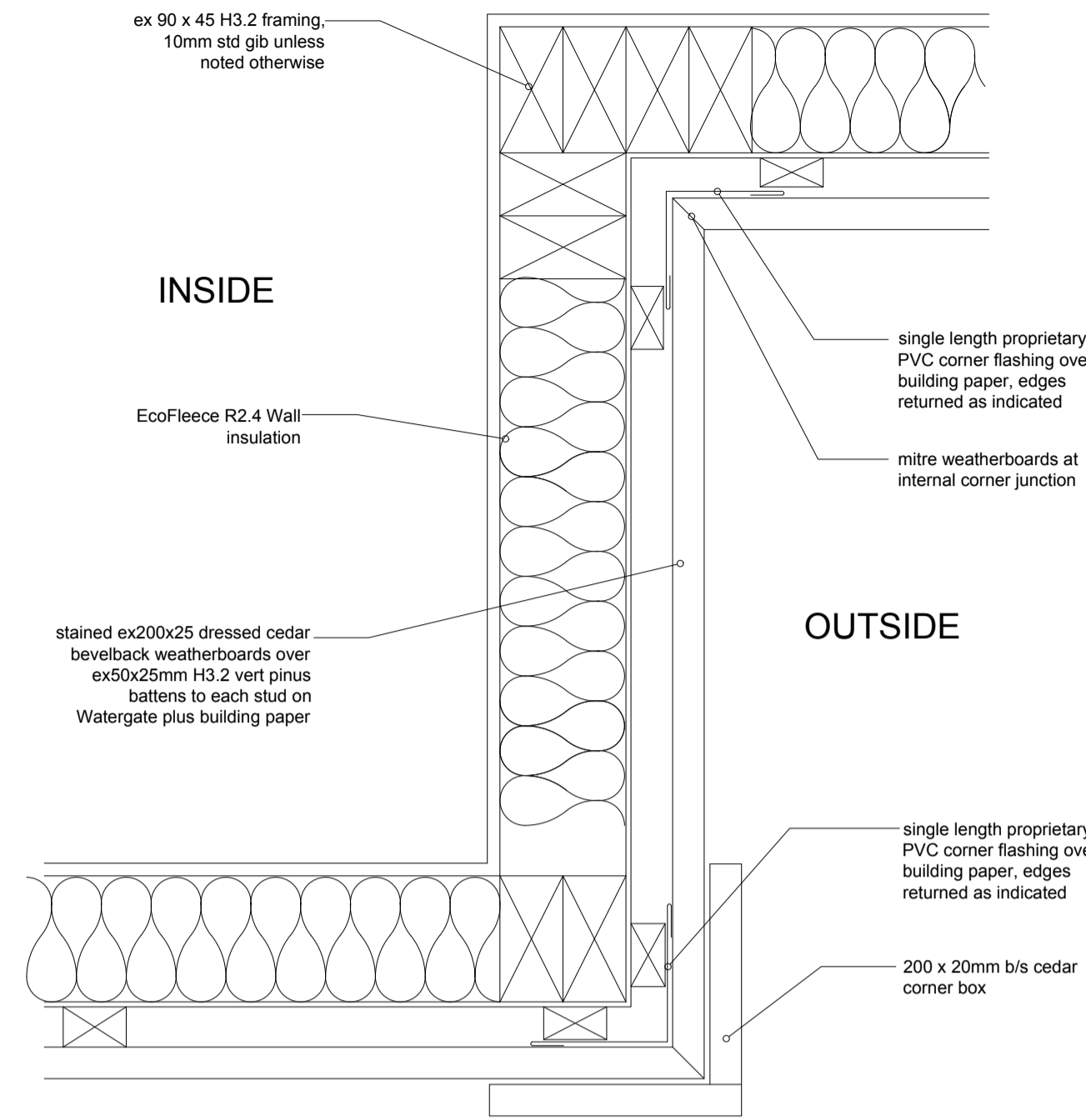

**23** Cladding Detail  
027 scale 1:5 (PLAN)

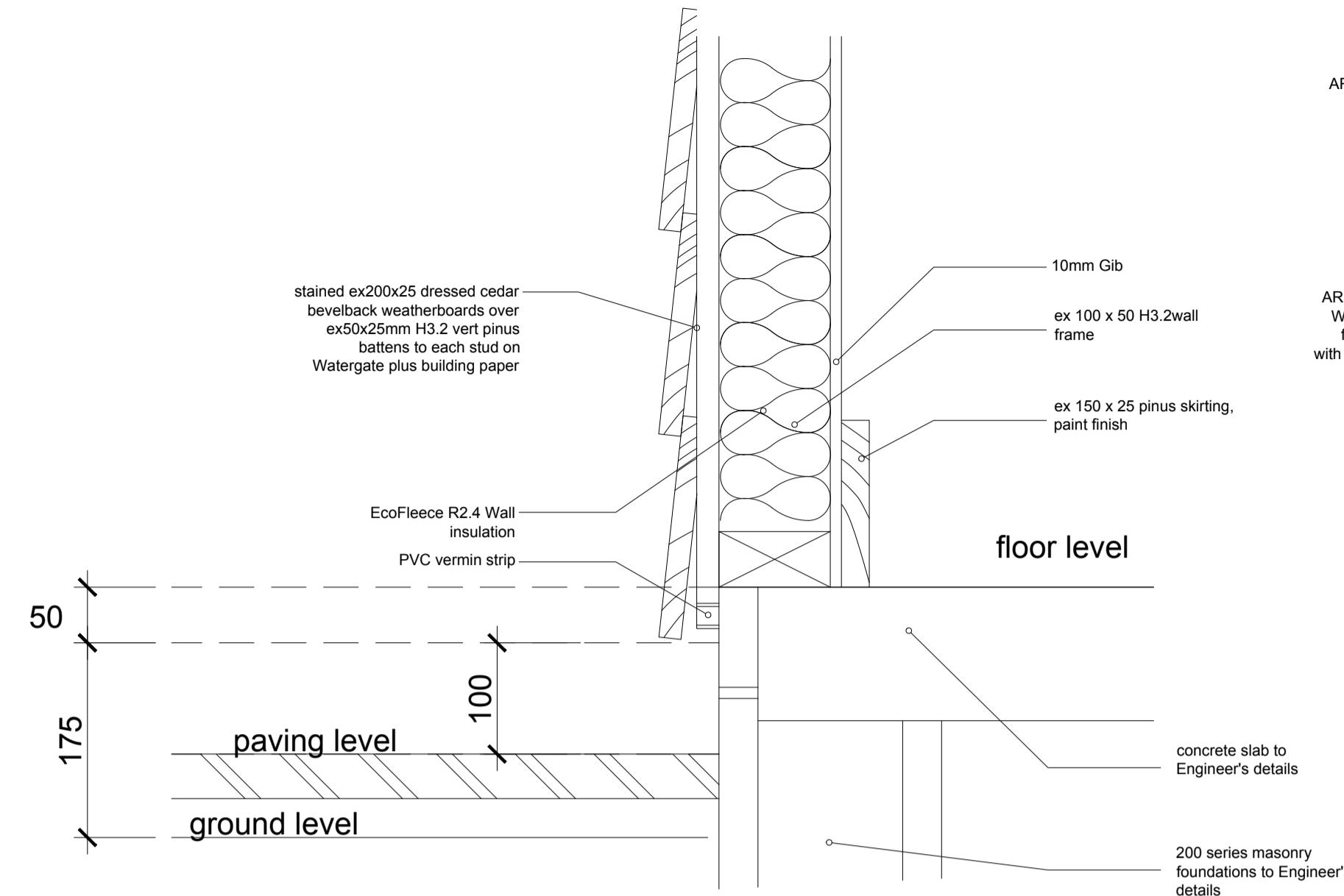

**24** Threshold Detail  
027 scale 1:5

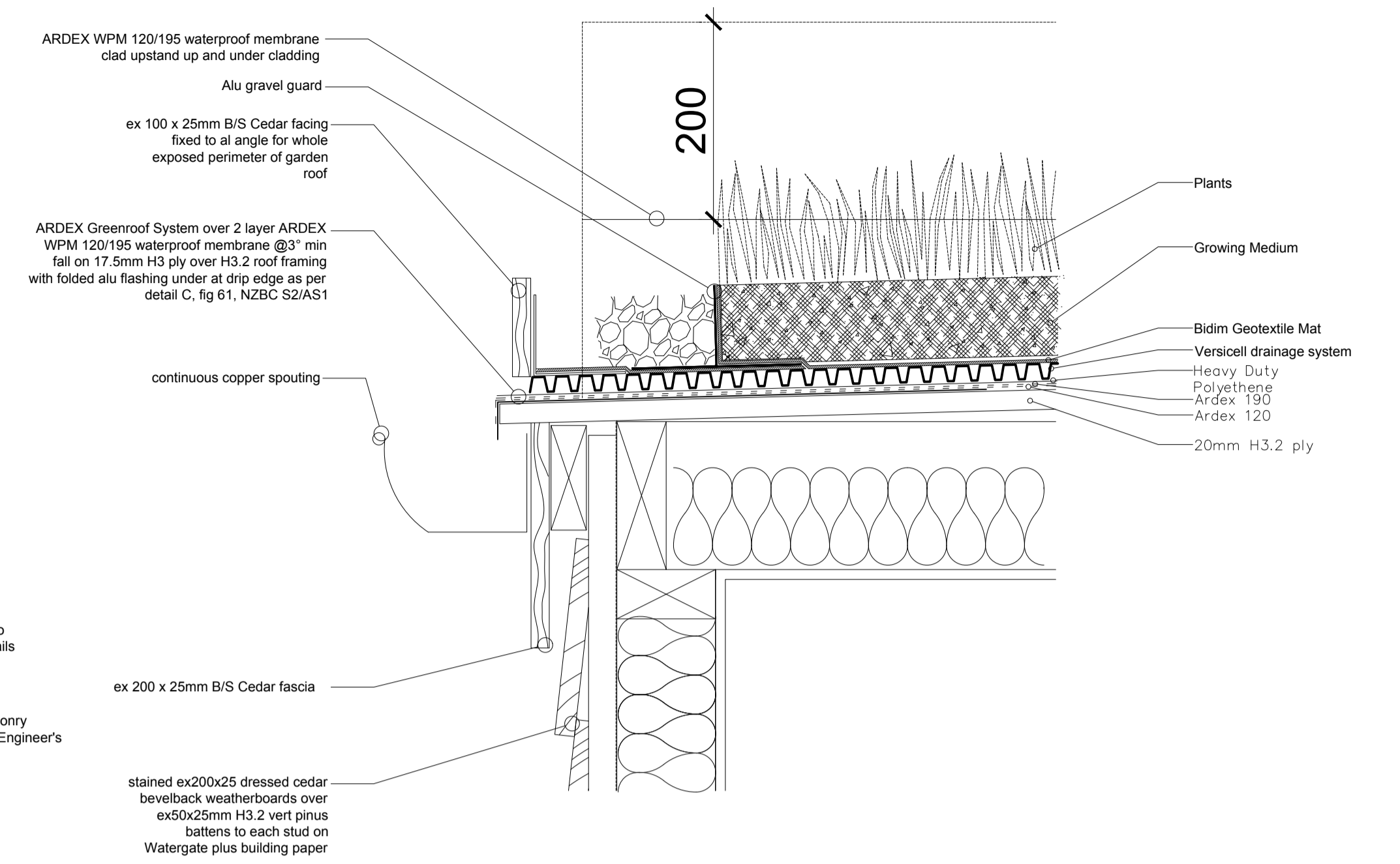

**25** Nuraply 3P Detail  
027 scale 1:5

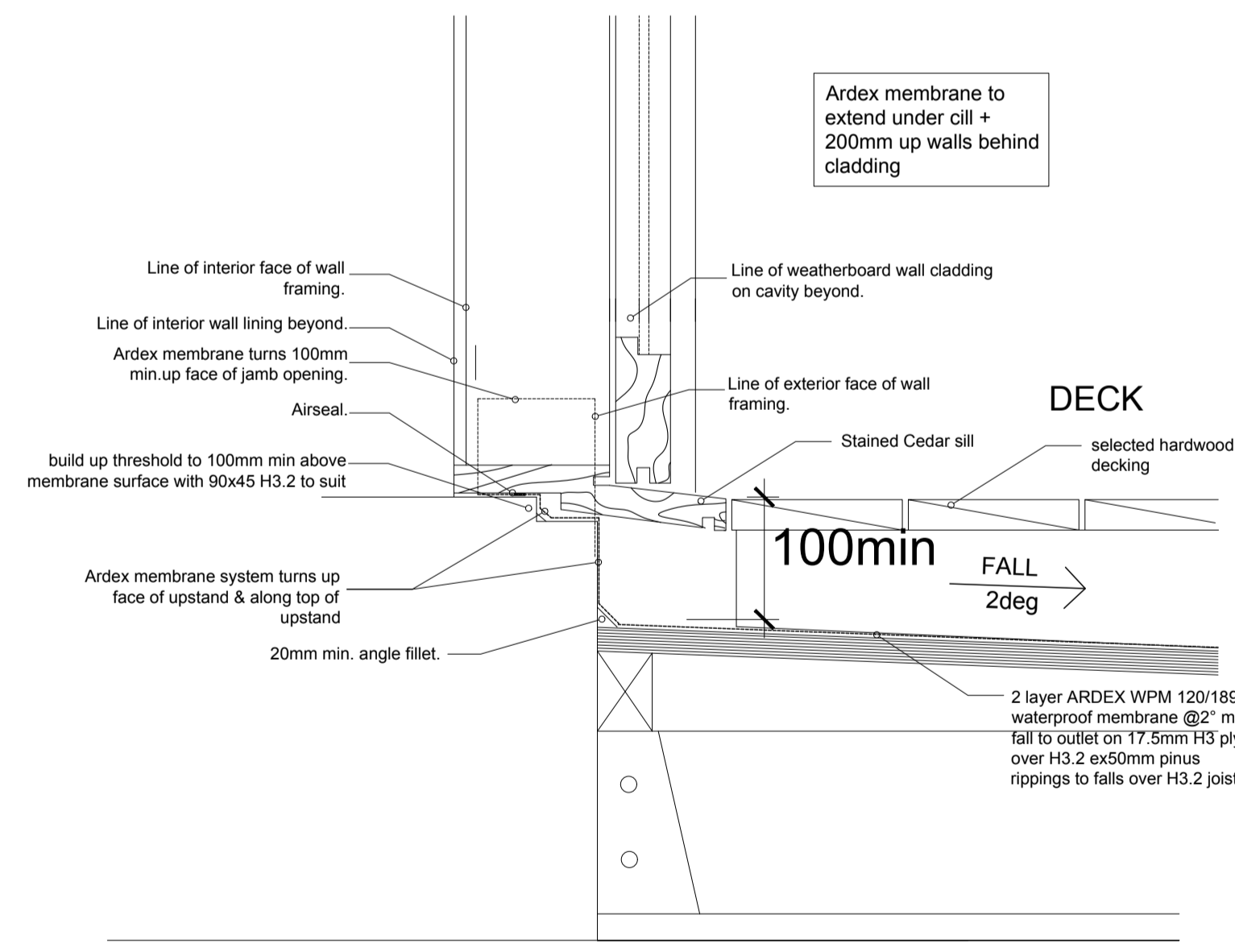

**26** Deck Threshold Detail  
027 scale 1:5

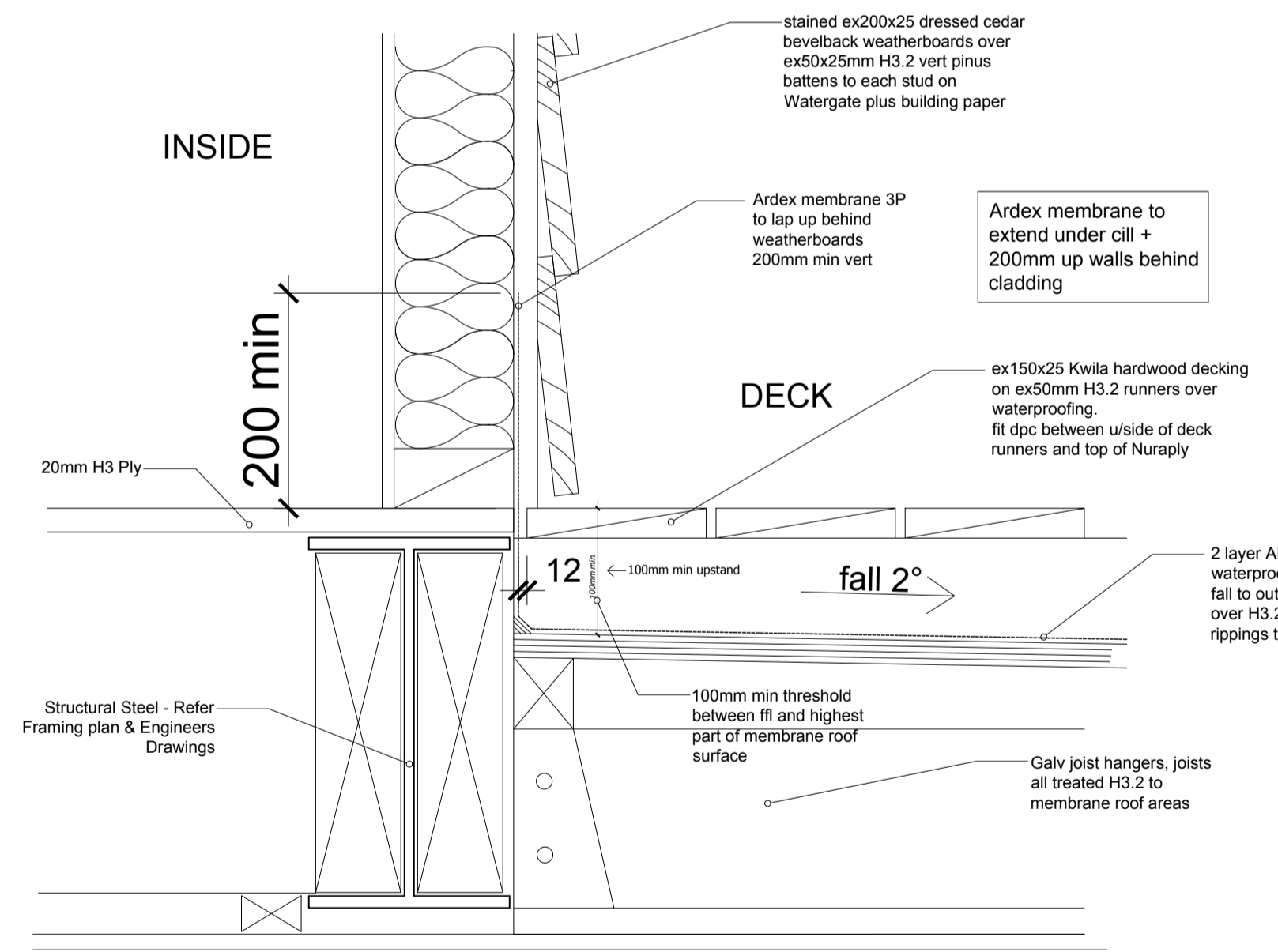

**27** Deck Detail  
027 scale 1:5

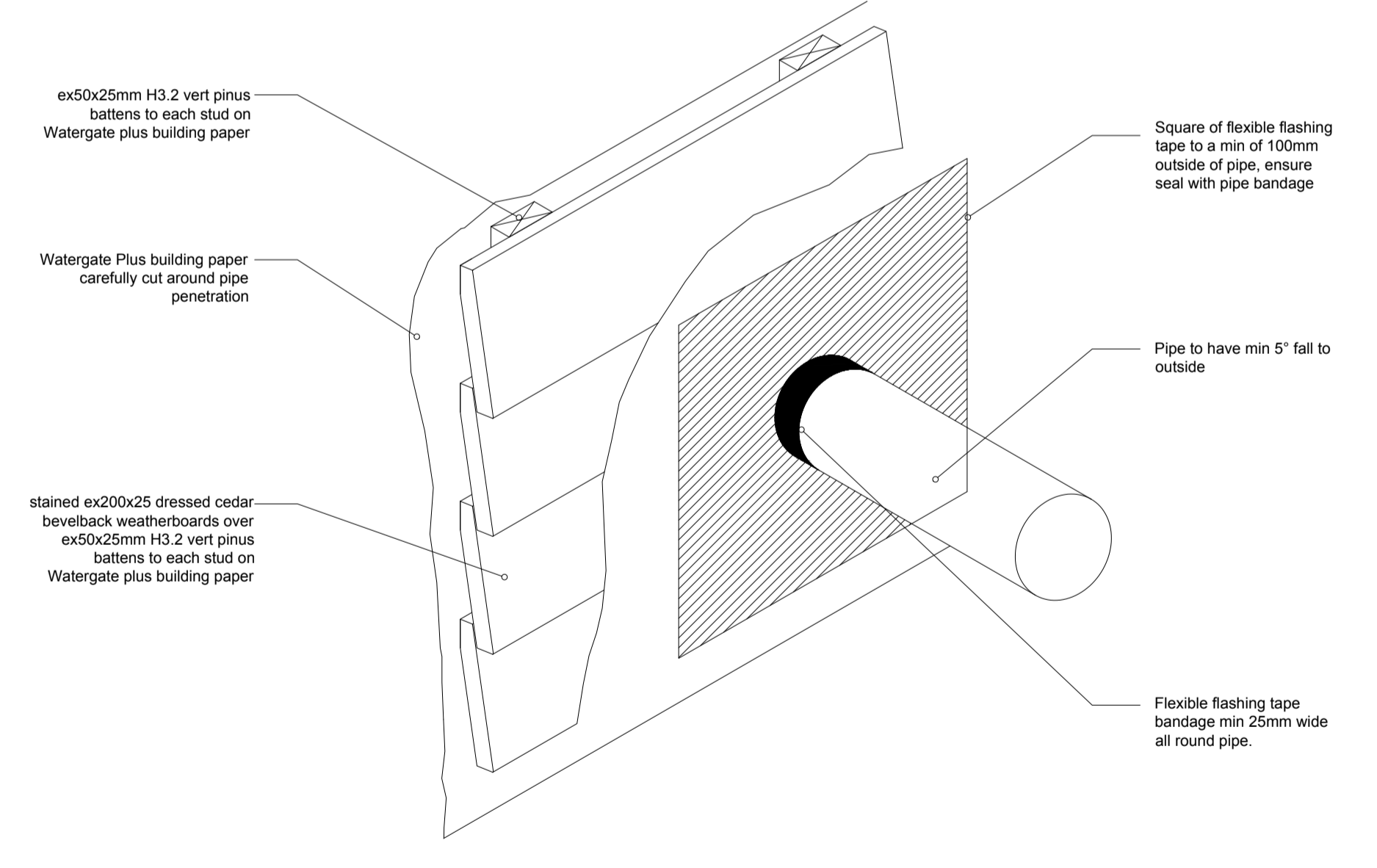

**28** Wall Penetration Detail  
027 scale 1:5

Revisions	General notes

NOTE:  
**STAGE 2  
CONSENT**

59 ROSEBERRY AVE BIRKENHEAD AUCKLAND TEL (09)418 2432 FAX (09)419 5142  
APARTMENT DEVELOPMENT  
81 Sarsfield Street, Herne Bay

**DELAMARE ARCHITECTS**

Date DEC'17  
Scale 1/5 @ A1  
Drawing Reference  
JOB no SAR 027  
revision  
Cod ref SAR  
CADREF

USE FOULDED DIMENSIONS. DO NOT SCALE FROM DRAWING. ALL LEVELS AND DIMENSIONS TO BE CHECKED ON SITE. DRAWING TO BE READ IN CONJUNCTION WITH ALL RELEVANT DOCUMENTS.  
©THE COPYRIGHT OF THIS DRAWING IS THE PROPERTY OF DAVID DELAMARE

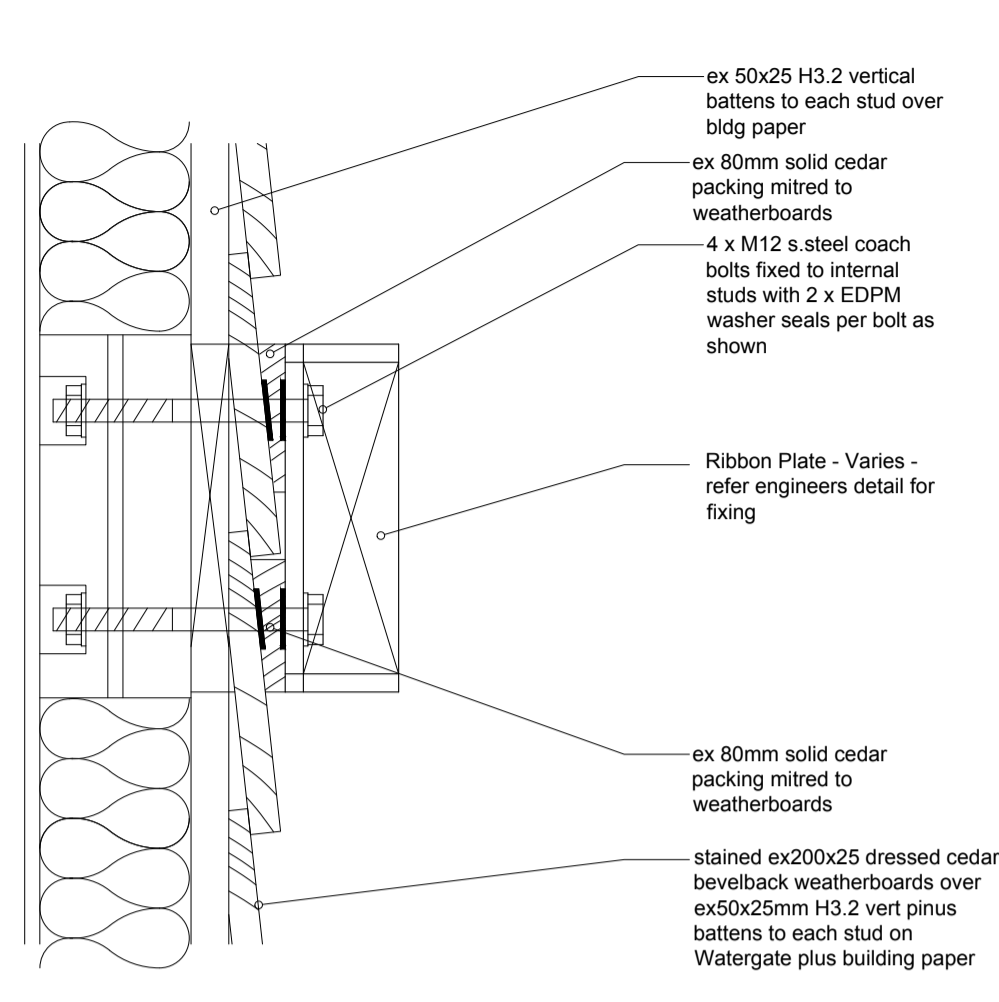

29 Ribbon-Plate Connection Detail  
028 scale 1:5

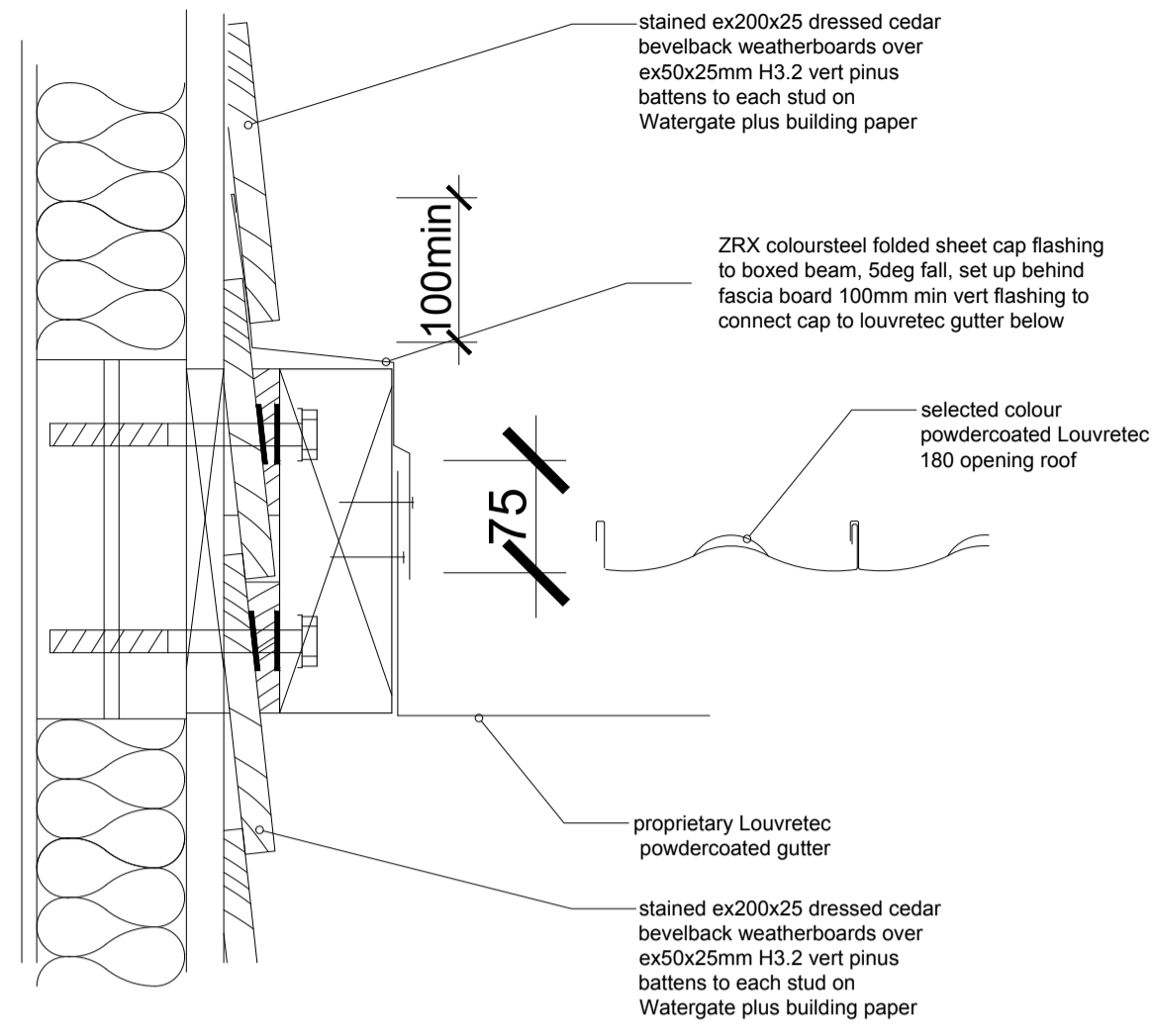

30 Louvretec Beam Connection Detail  
028 scale 1:5

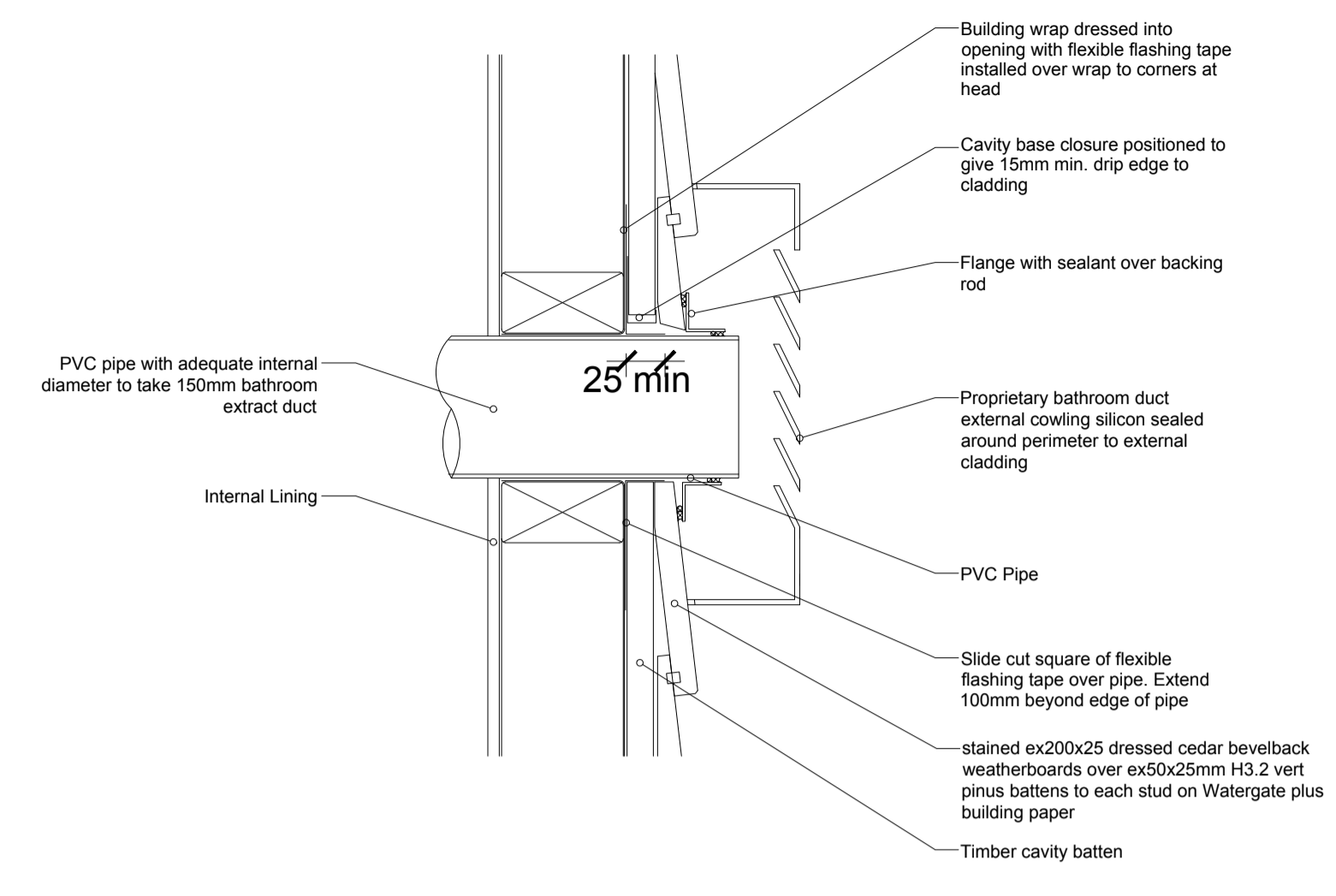

31 Wall Penetration Detail  
028 scale 1:5

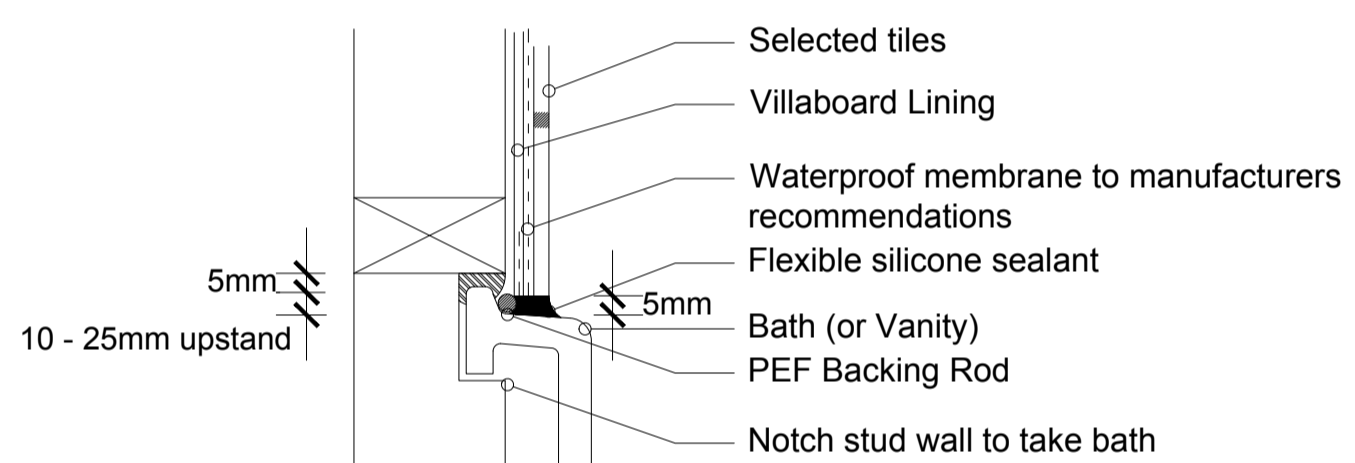

Bath / Vanity Junction  
scale 1:5

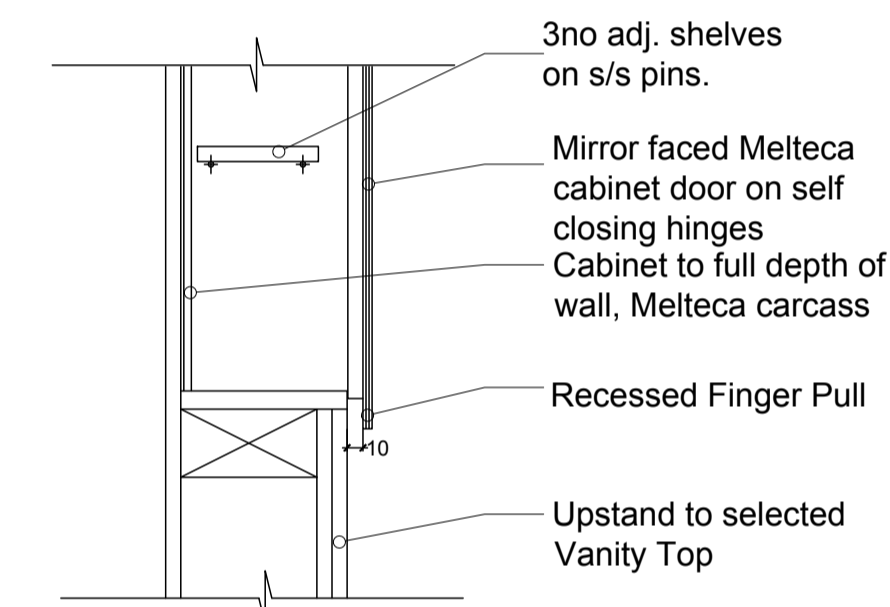

Vanity Cabinet  
scale 1:5

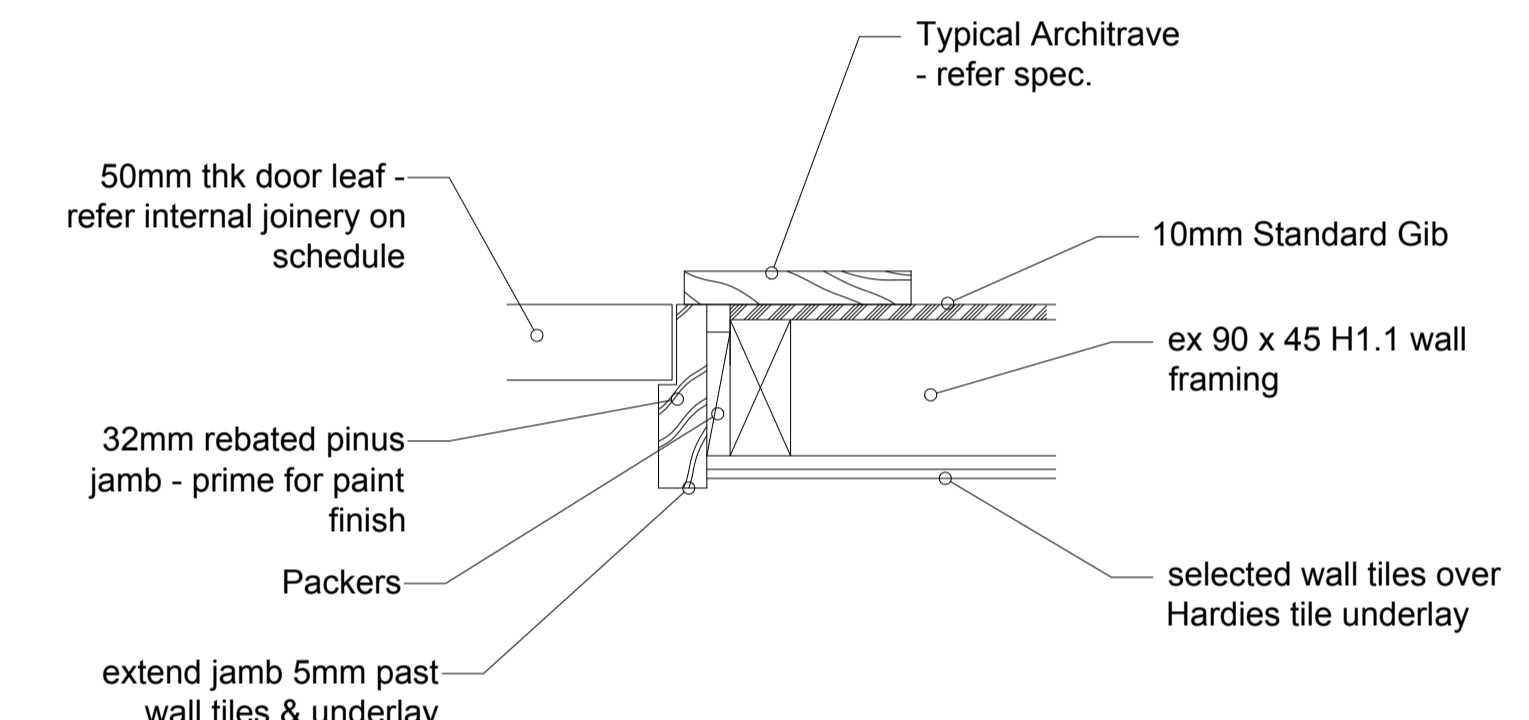

Bathroom Jamb Detail  
scale 1:5

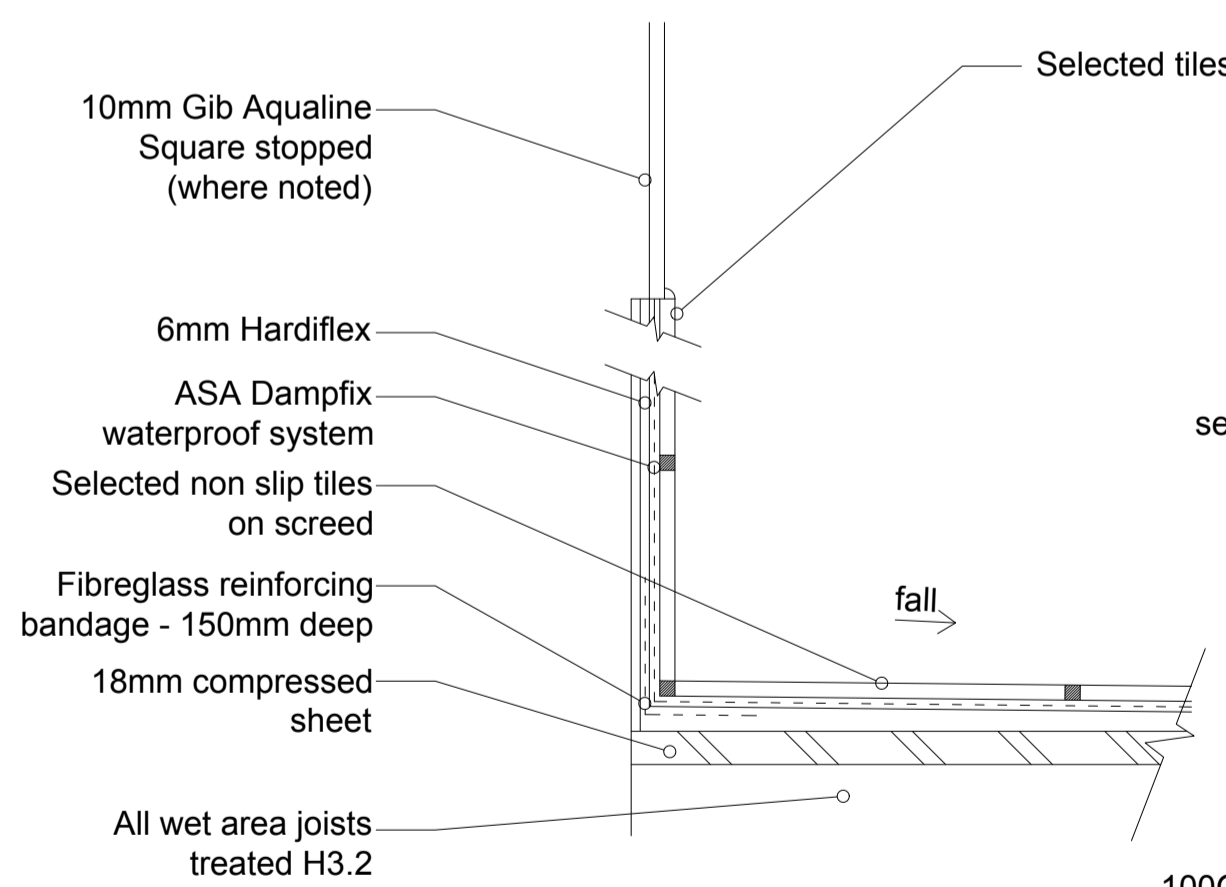

D Shower wall / floor junction  
scale 1:5

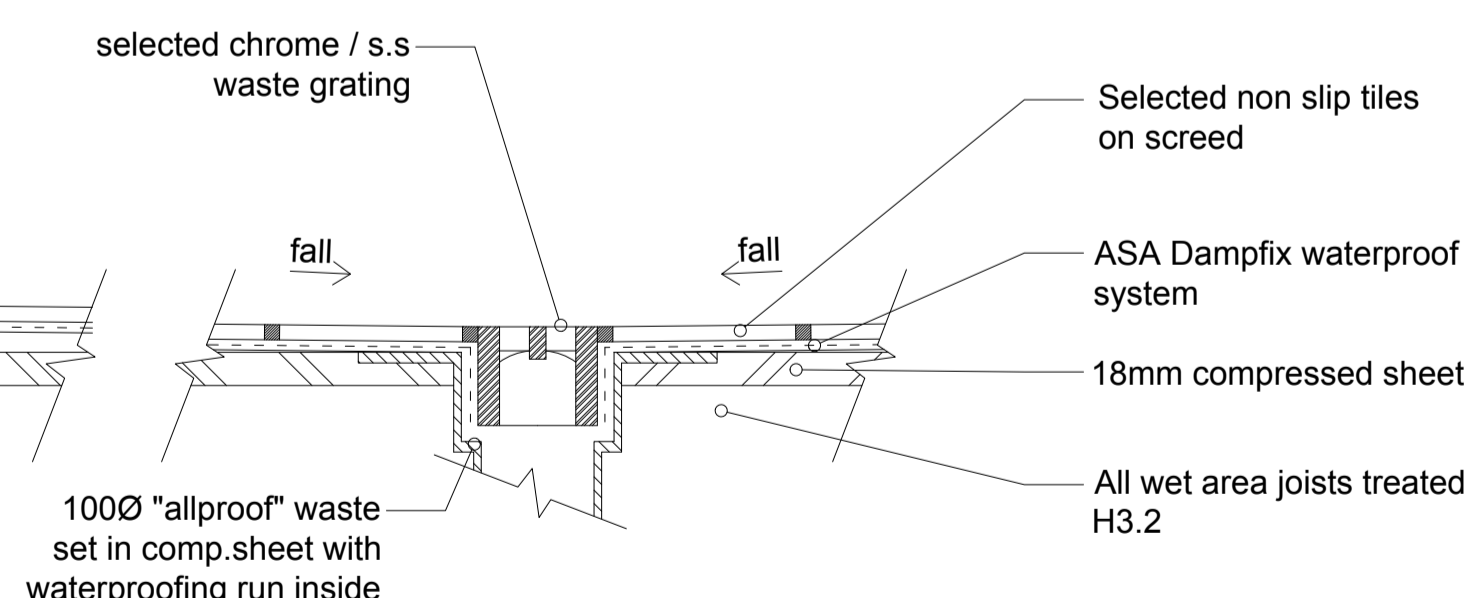

C Shower 'allproof'  
scale 1:5

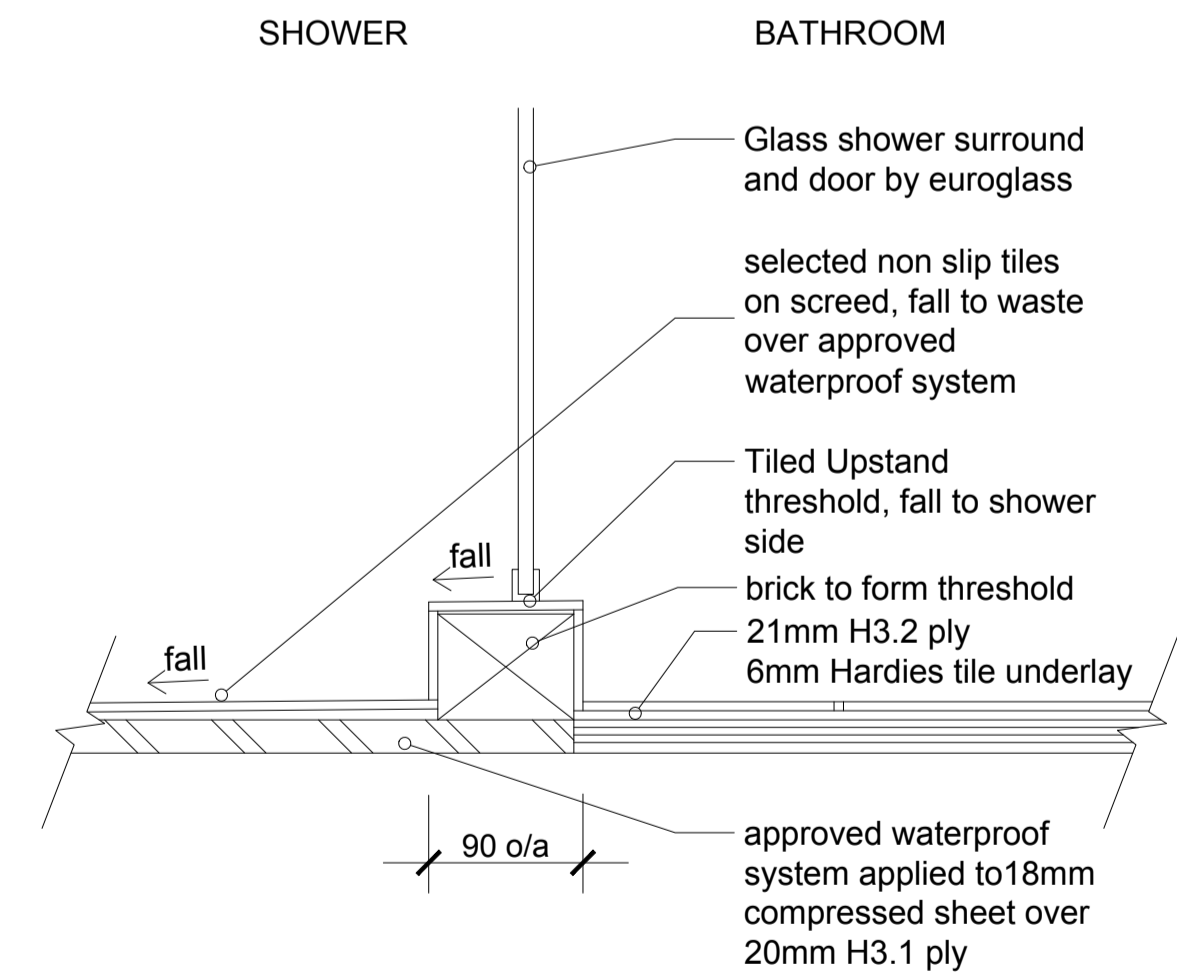

B Shower threshold  
scale 1:5

Revisions	General notes

NOTE:  
**STAGE 2  
CONSENT**

59 ROSEBERRY AVE BIRKENHEAD AUCKLAND TEL (09)418 2432 FAX (09)419 5142  
APARTMENT DEVELOPMENT  
81 SANSFIELD STREET, HERNE BAY

**DELAMARE ARCHITECTS**

Date DEC'17  
Scale 1/5 @ A1  
Drawing Reference  
job no. SAR 028  
revision  
CADREF

USE DIMENSIONS: DO NOT SCALE FROM DRAWING. ALL LEVELS AND DIMENSIONS TO BE CHECKED ON SITE. DRAWING TO BE READ IN CONJUNCTION WITH ALL RELEVANT DOCUMENTS.  
©THE COPYRIGHT OF THIS DRAWING IS THE PROPERTY OF DAVID DELAMARE

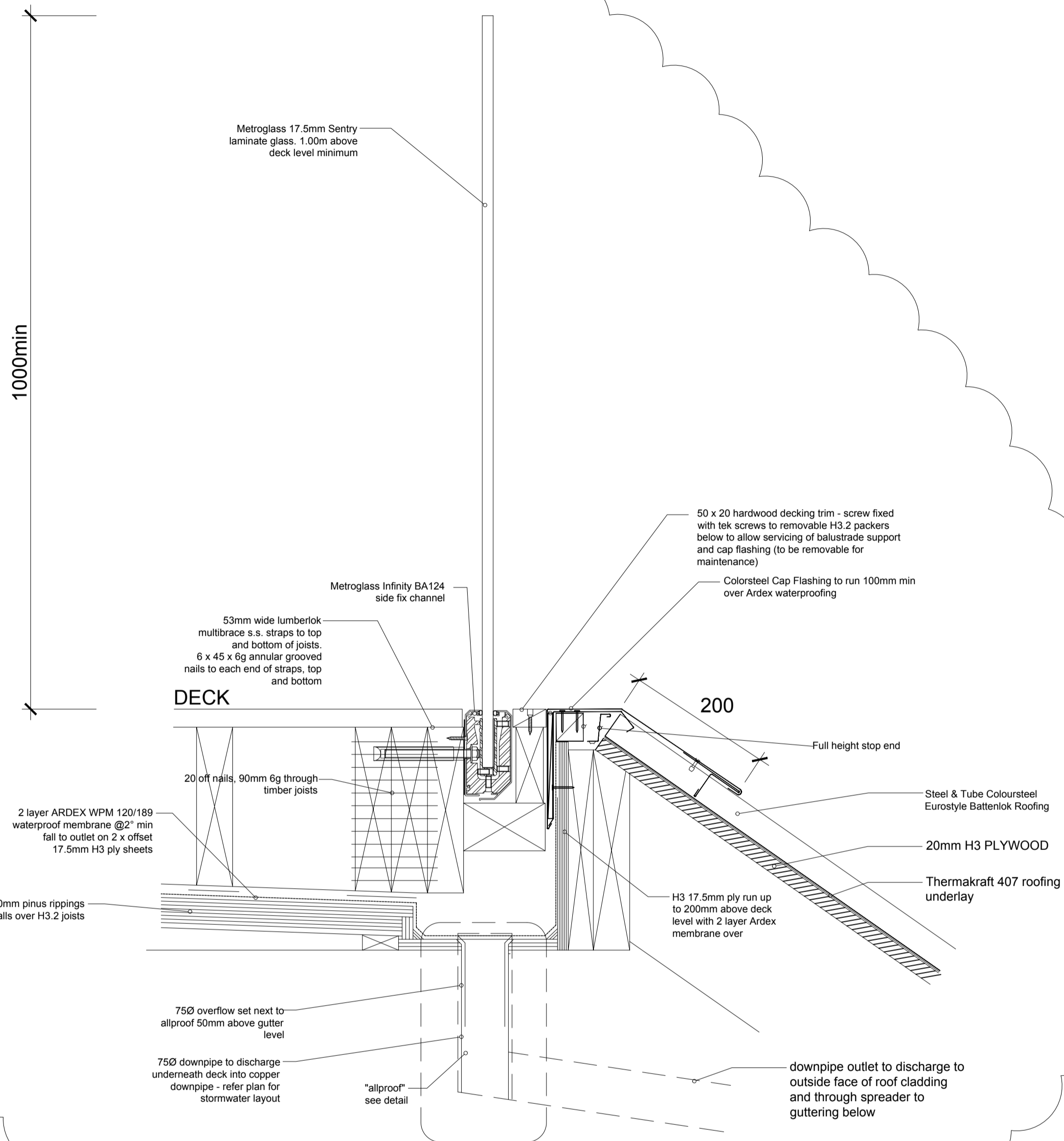

**33 Deck Detail**  
029 scale 1:5

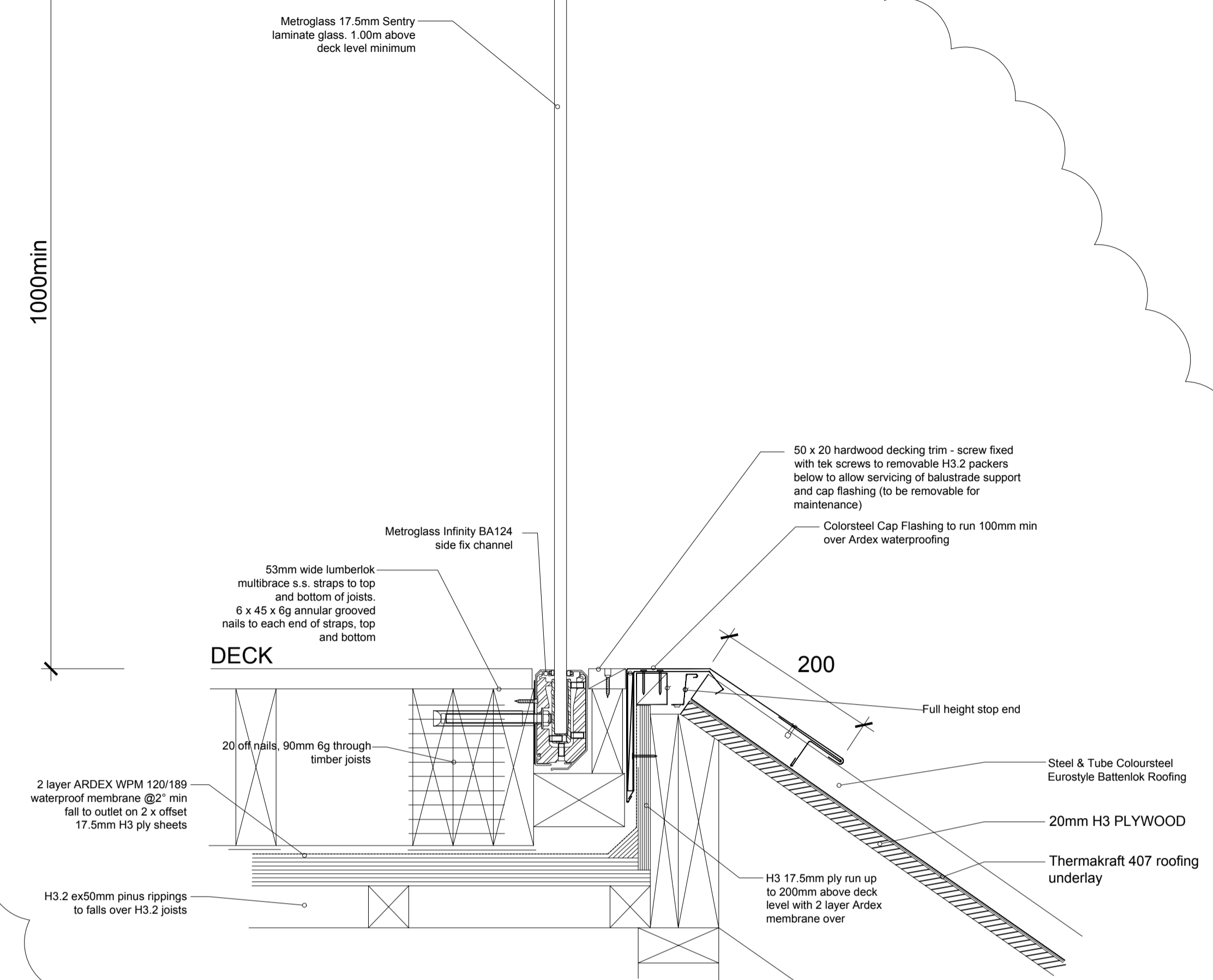

**33 Deck Detail**  
029 scale 1:5

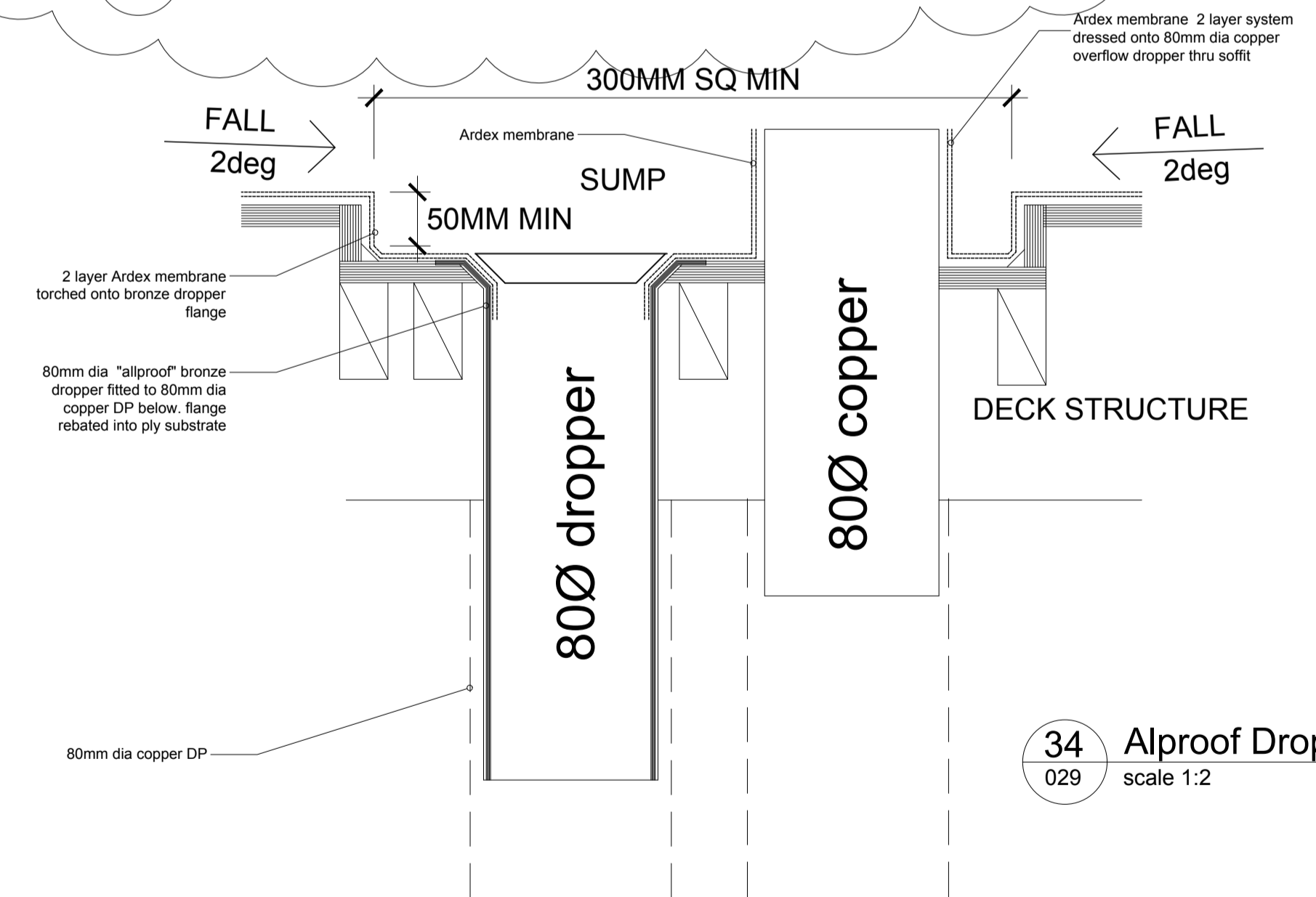

**34 Alproof Dropper**  
029 scale 1:2

Revisions	General notes

NOTE:  
**AMENDMENT**  
**09/18**

59 ROSEBERRY AVE, BIRKENHEAD, AUCKLAND. TEL (09)418 2432 FAX (09)419 5142  
**APARTMENT DEVELOPMENT**  
 81 SANSFIELD STREET, HERNE BAY

**DELAMARE ARCHITECTS**

Date: DEC'17  
 Scale: 1/5 @ A1  
 Drawing Reference: SAR 029  
 Drawing No: SAR 029  
 Revision: CADREF  
 Cid ref: SAR  
 CADREF

USE FIGURED DIMENSIONS. DO NOT SCALE FROM DRAWING. ALL LEVELS AND DIMENSIONS TO BE CHECKED ON SITE. DRAWING TO BE READ IN CONJUNCTION WITH ALL RELEVANT DOCUMENTS. © THE COPYRIGHT OF THIS DRAWING IS THE PROPERTY OF DELAMARE.

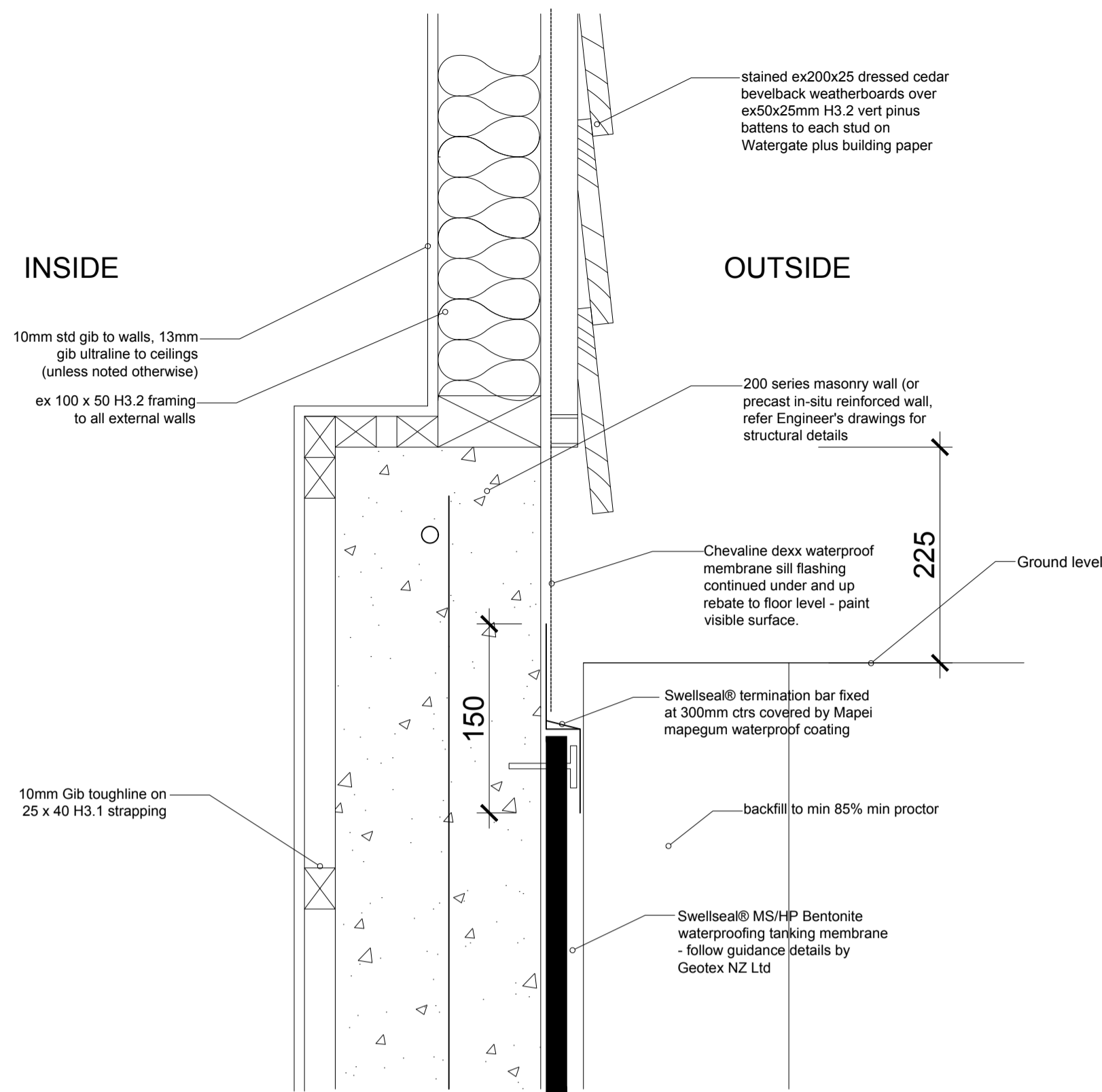

**35** Slab Tanking Detail  
030 scale 1:5 (typical)

Refer Engineers Details for footing and slab and structural details

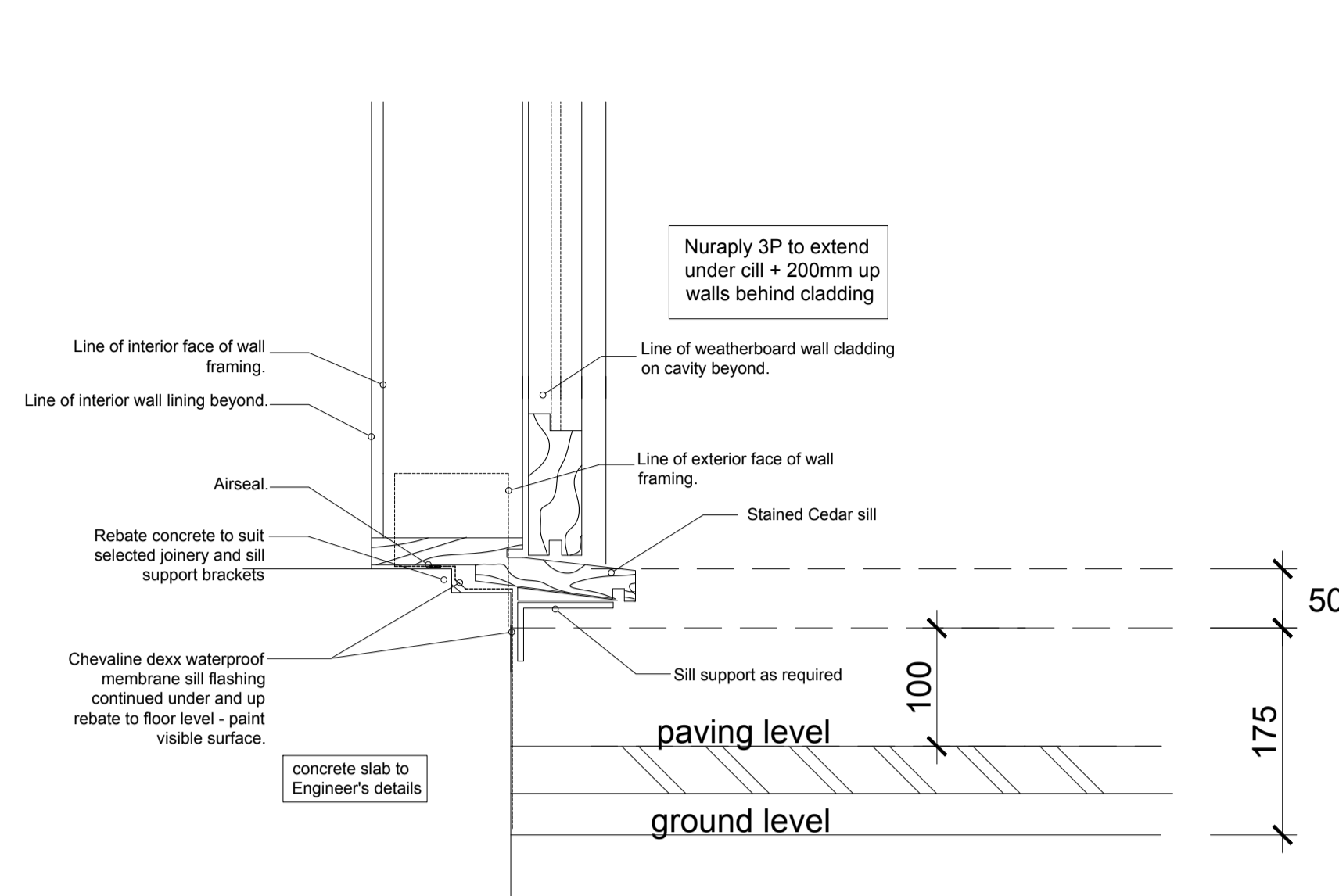

**36** Level Threshold Detail  
030 scale 1:5

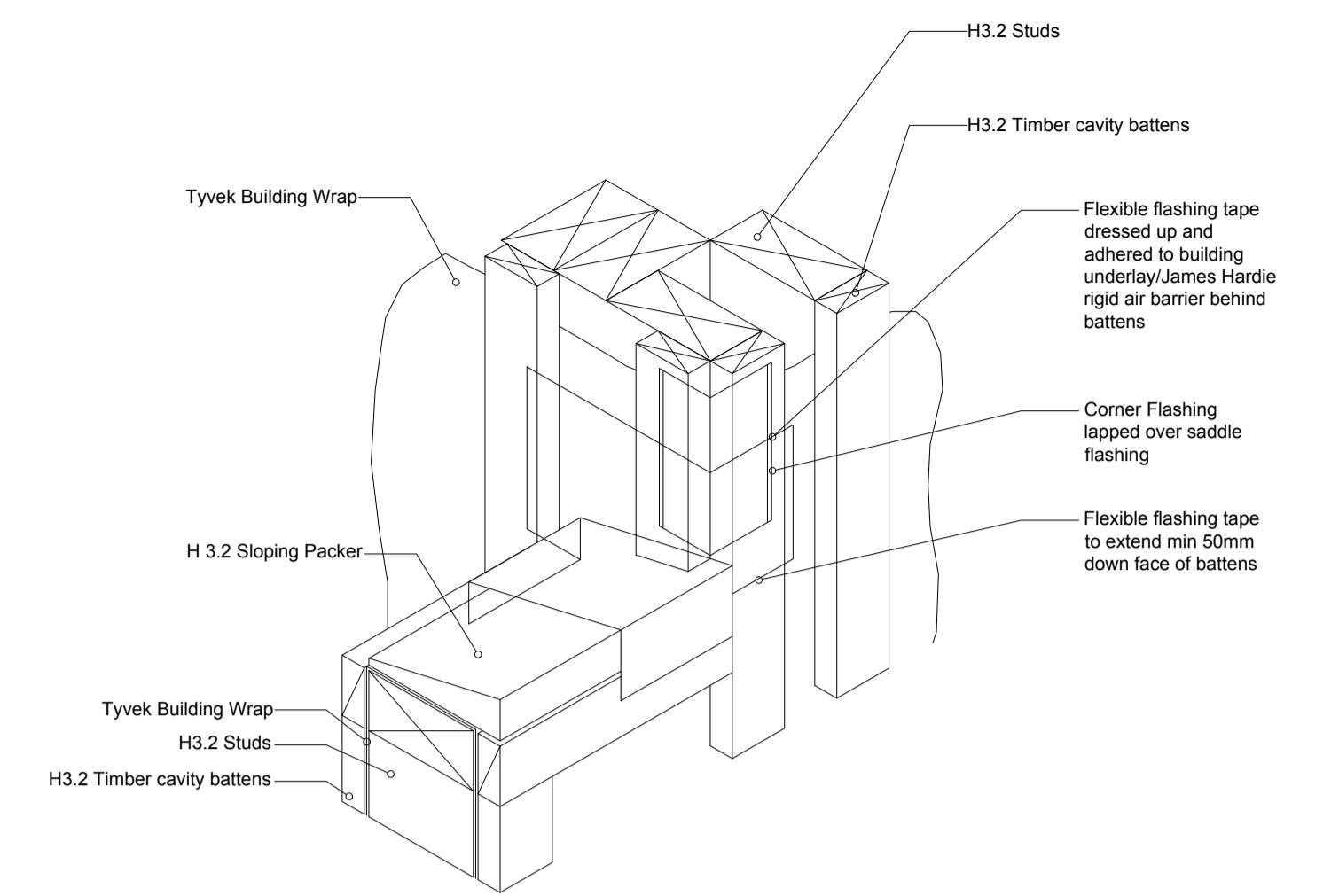

**38** Parapet to Wall Junction  
030 scale 1:5

H3.2 Jamb liners

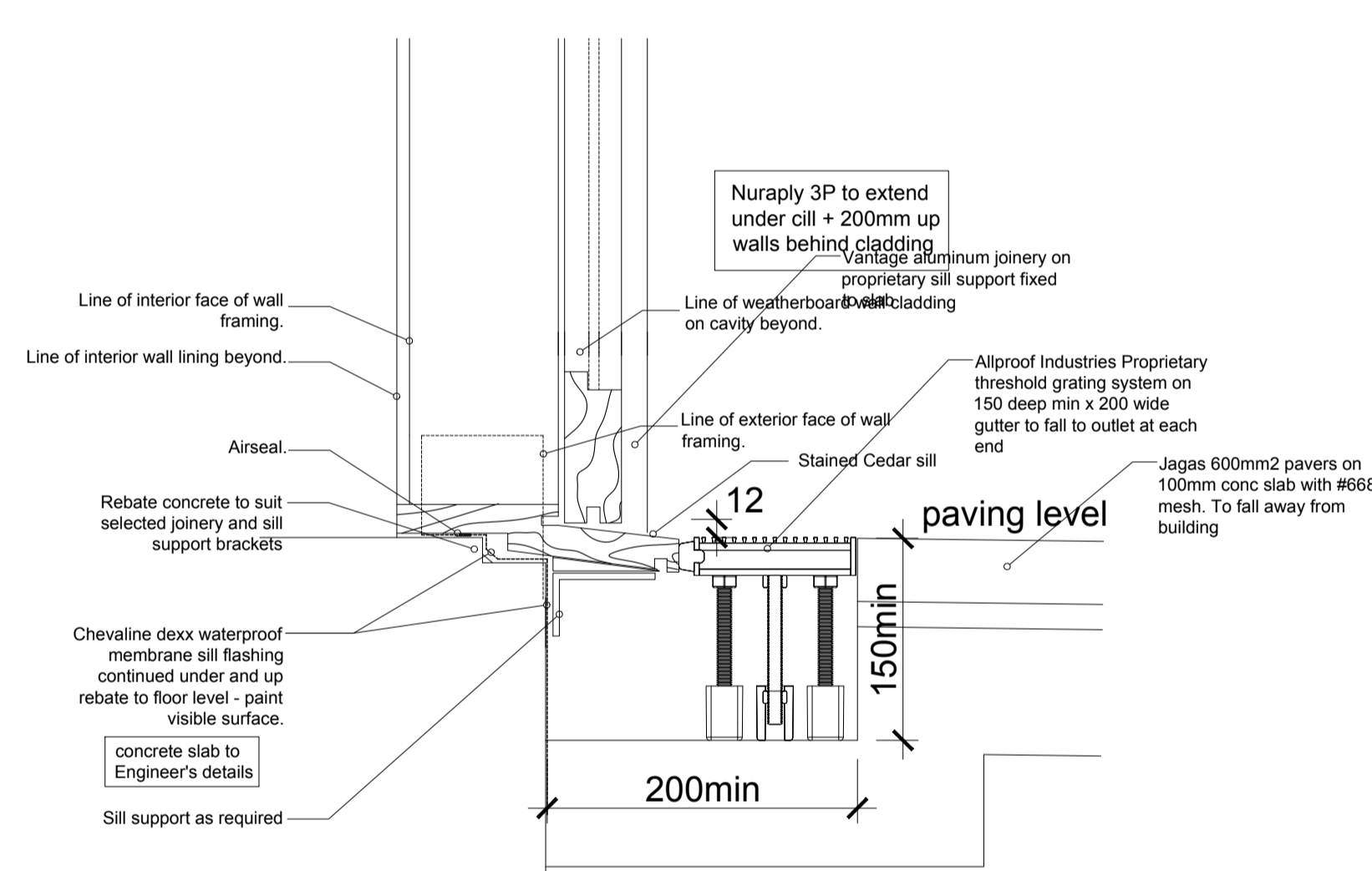
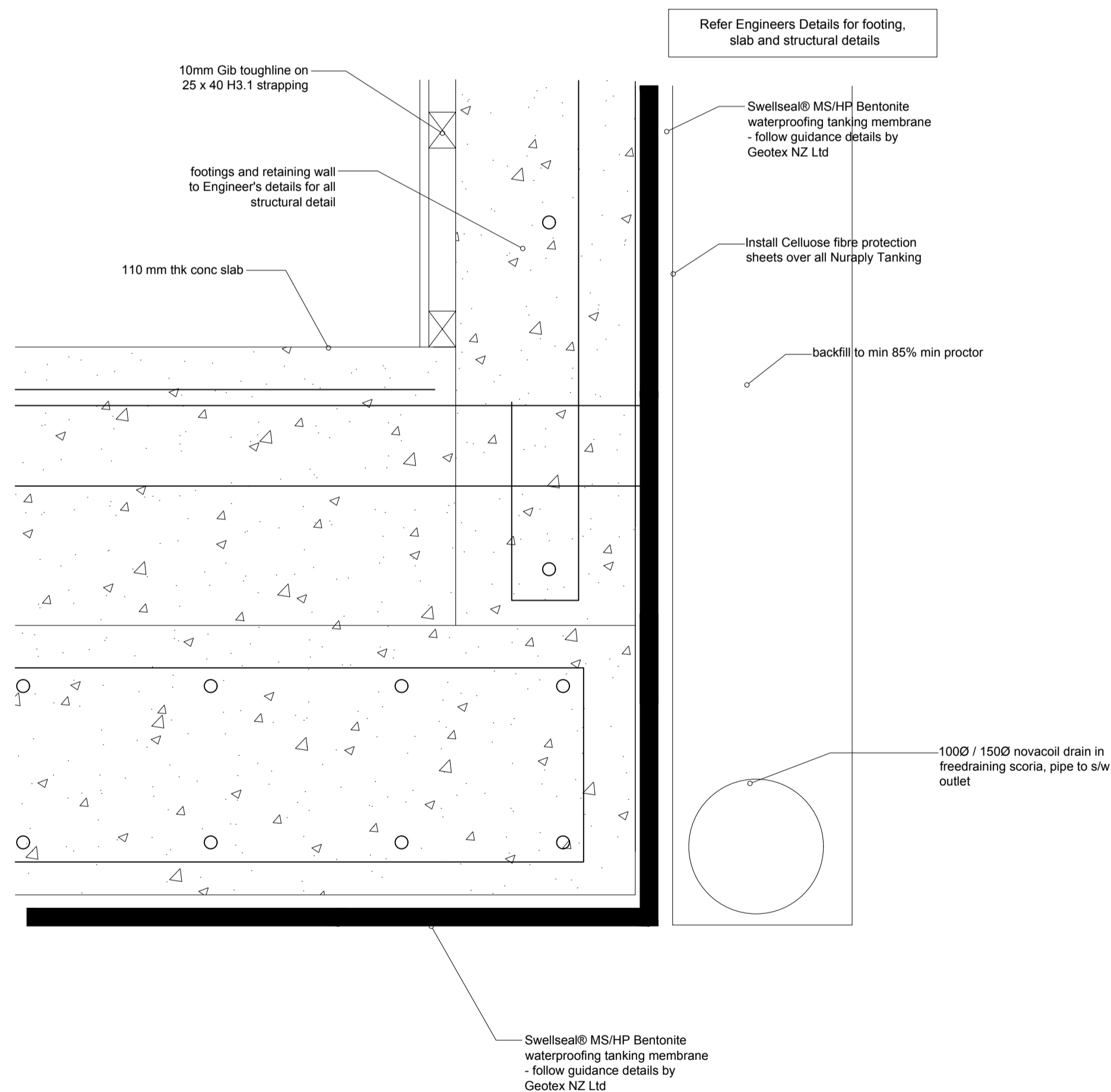

**37** Level Threshold Detail  
030 scale 1:5

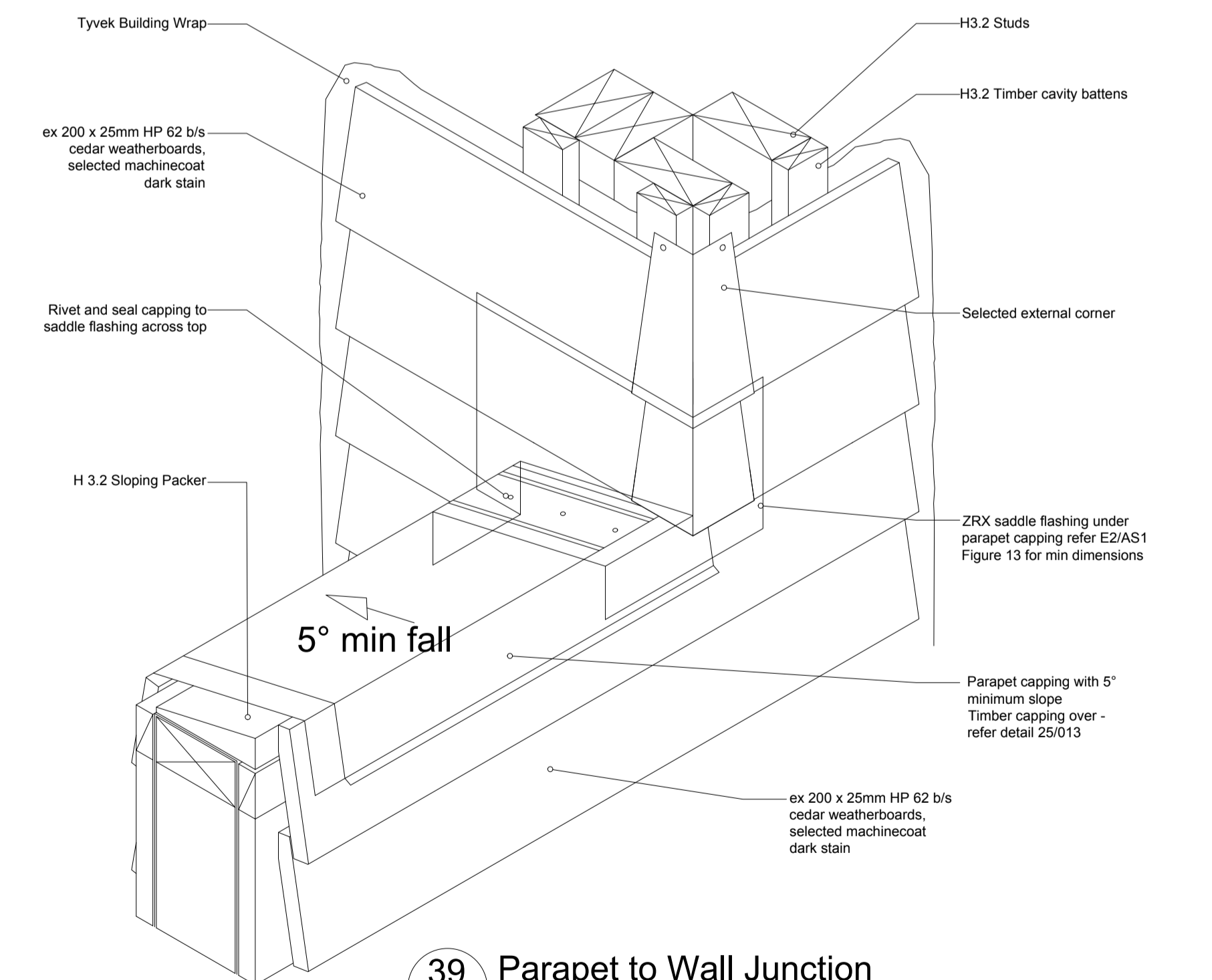

**39** Parapet to Wall Junction  
030 scale 1:5

All underground tanking & related systems to be installed by Auckland Council approved applicators who provide PS3 to Council satisfaction.  
Tanking Details are Indicitive and Geotex NZ Ltd - Swellseal details take precedent

Revisions	General notes

NOTE:  
**STAGE 2  
CONSENT**

59 ROSEBERRY AVE BIRKENHEAD AUCKLAND TEL (09)418 2432 FAX (09)419 5142  
APARTMENT DEVELOPMENT  
81 SANSFIELD STREET, HERNE BAY

**DELAMARE ARCHITECTS**

Date DEC'17  
Scale 1/5 @ A1  
Drawing Reference  
job no SAR 030  
revision  
Cod ref SAR  
CADREF

USE POURED DIMENSIONS. DO NOT SCALE FROM DRAWING.  
ALL LEVELS AND DIMENSIONS TO BE CHECKED ON SITE.  
DRAWING TO BE READ IN CONJUNCTION WITH ALL RELEVANT DOCUMENTS.  
© THE COPYRIGHT OF THIS DRAWING IS THE PROPERTY OF DAVID DELAMARE

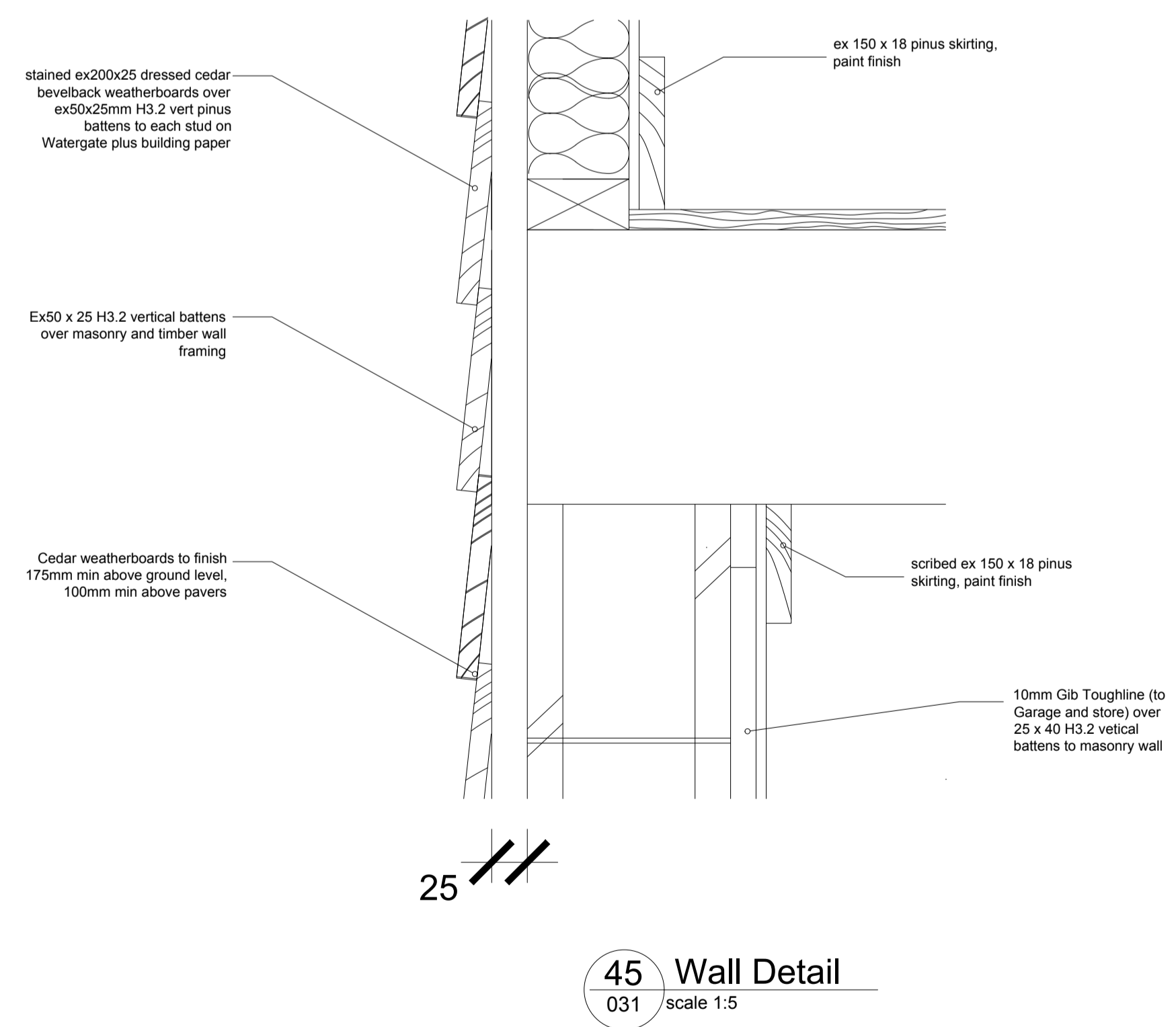
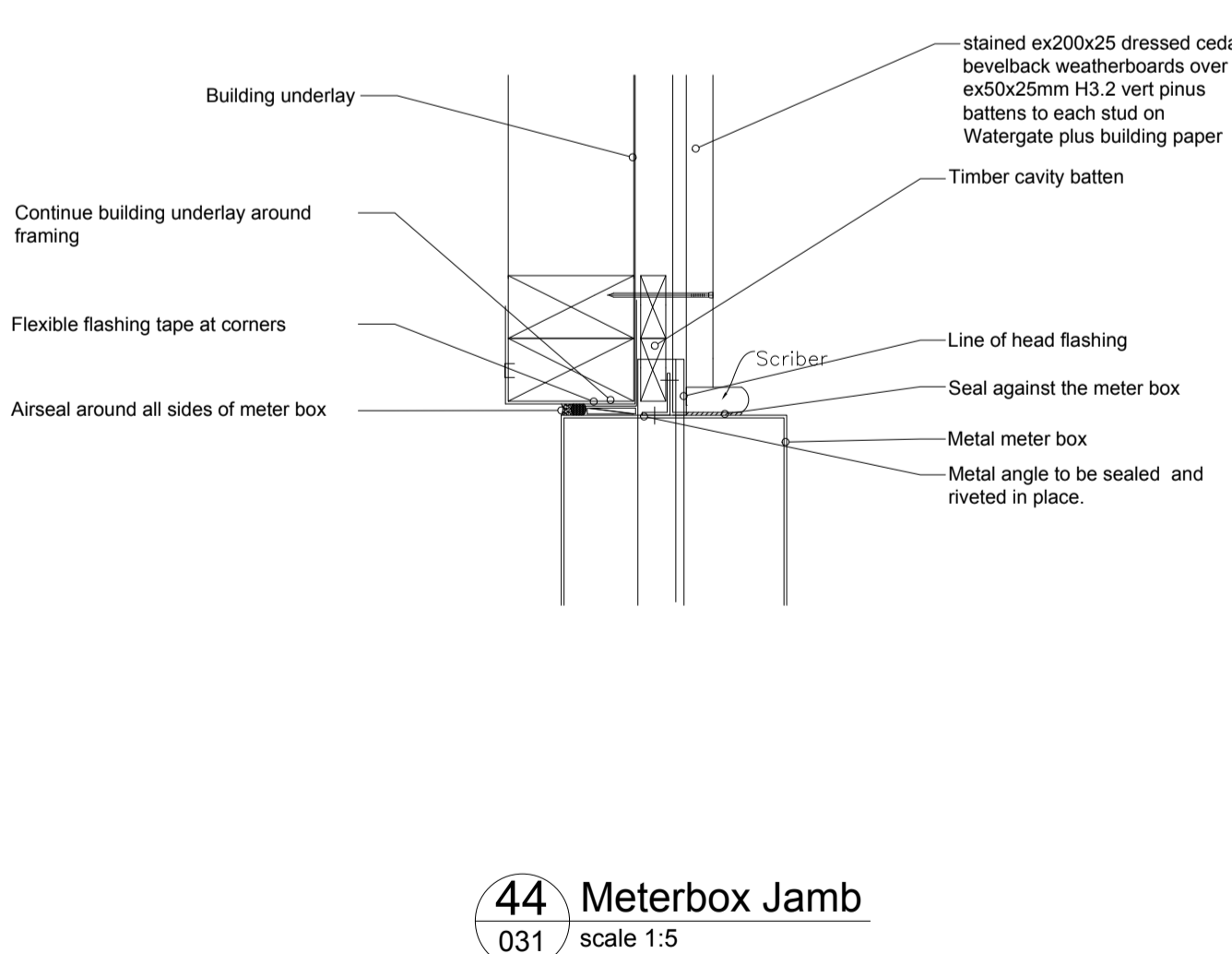
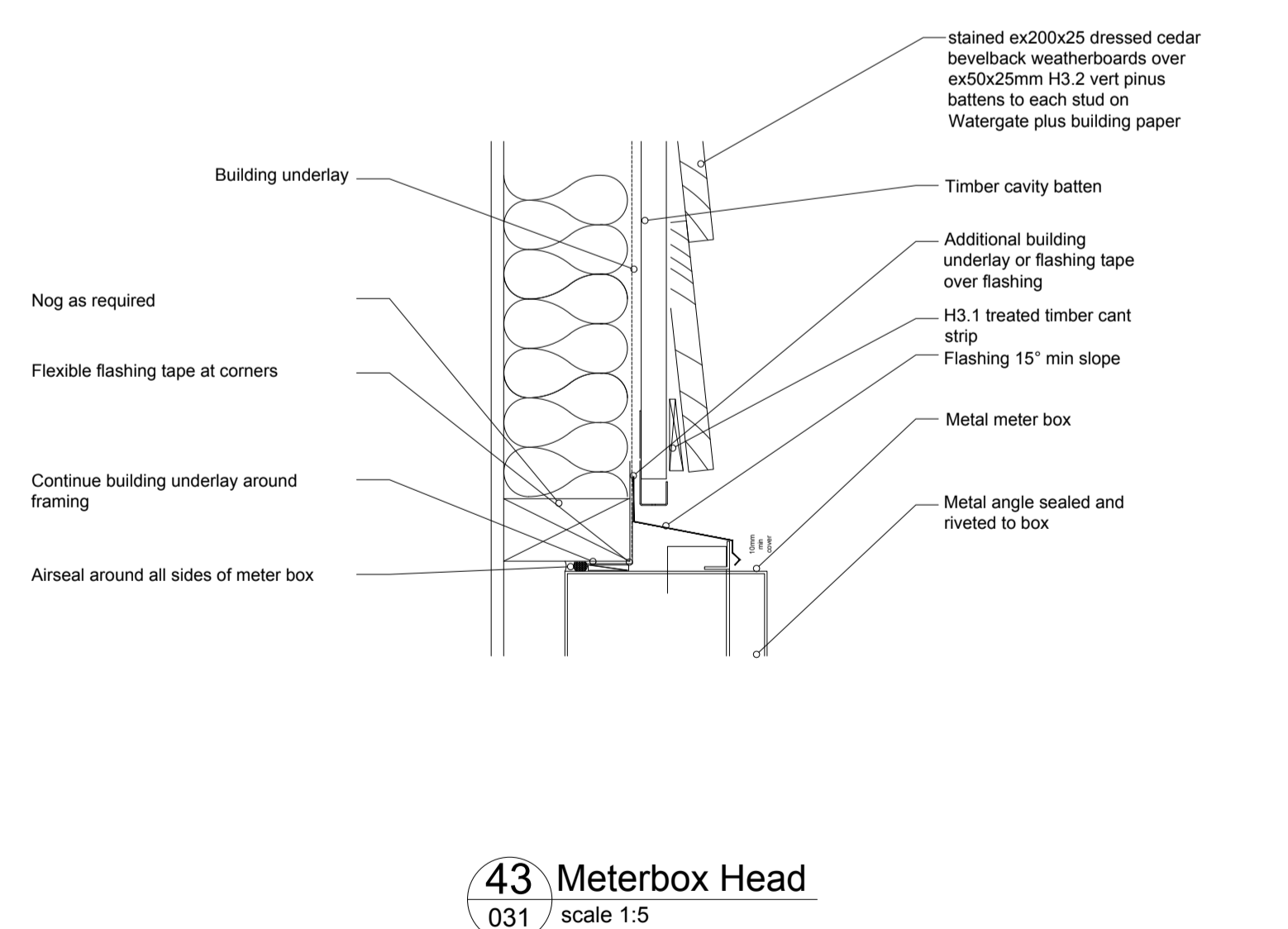
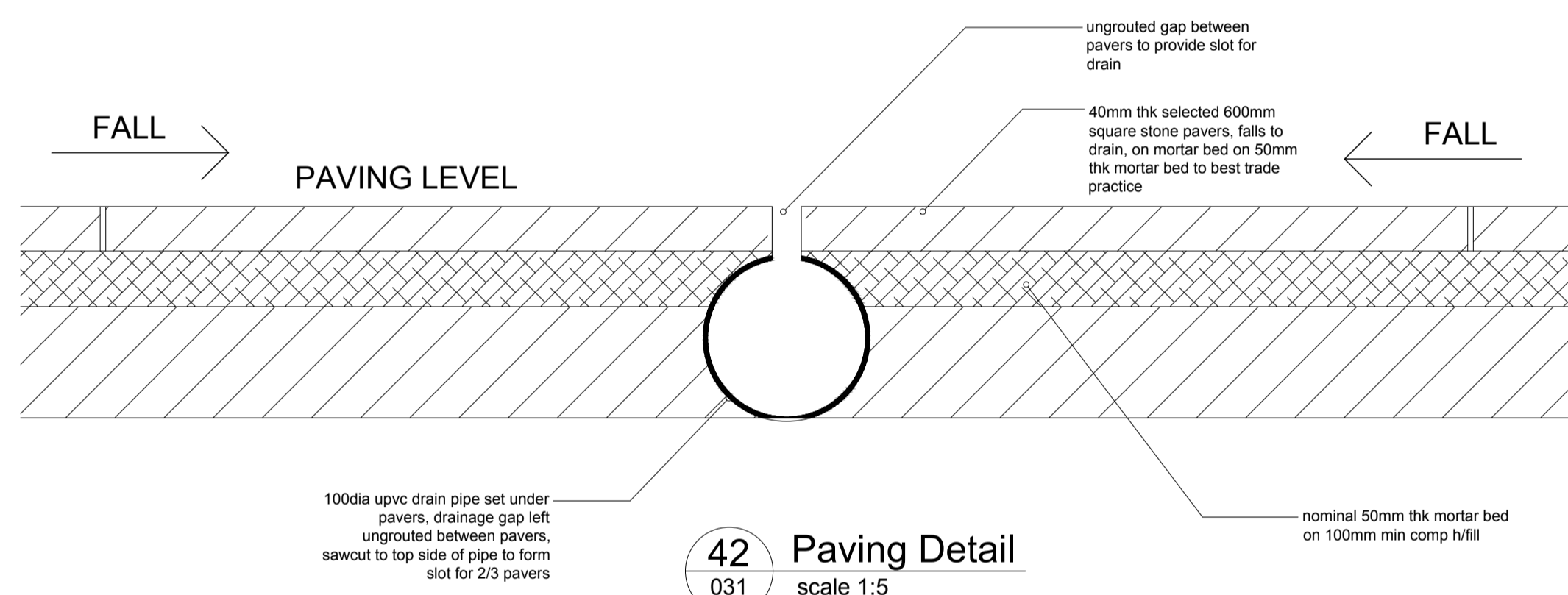
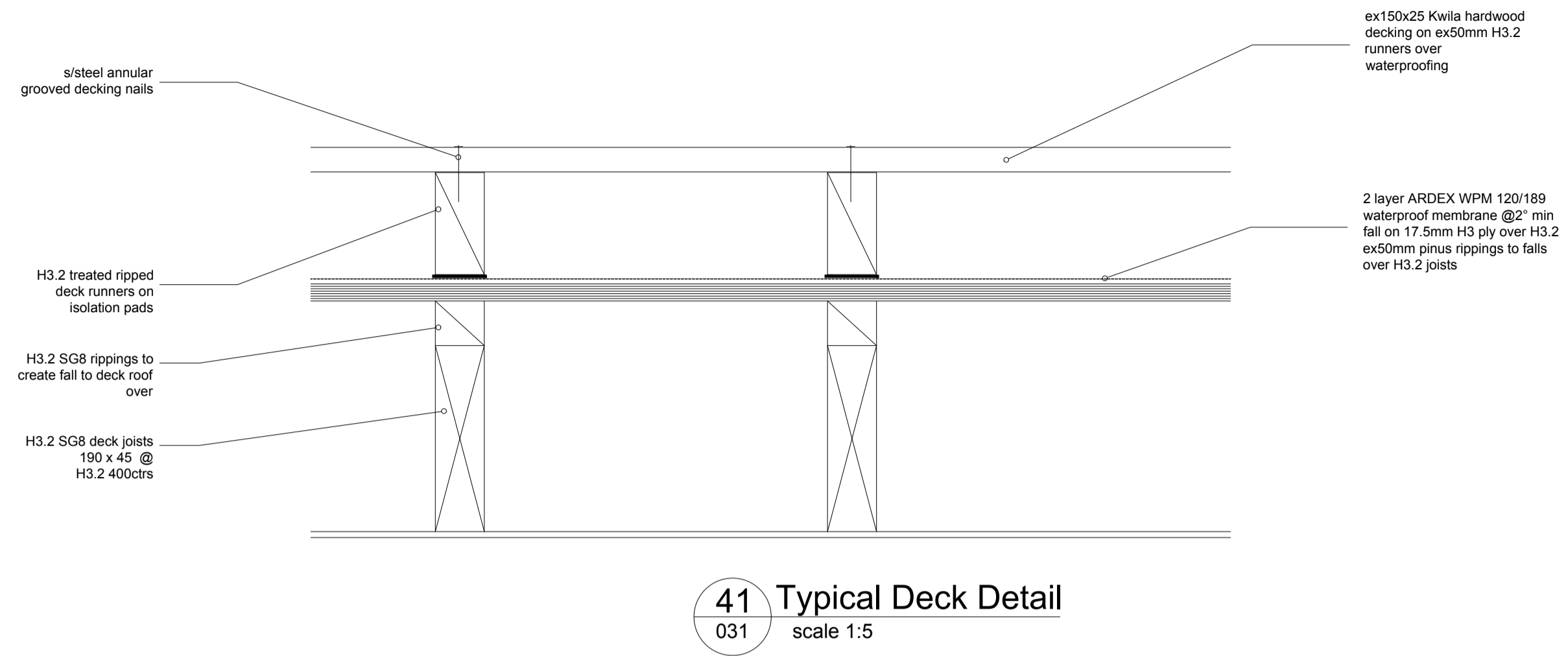
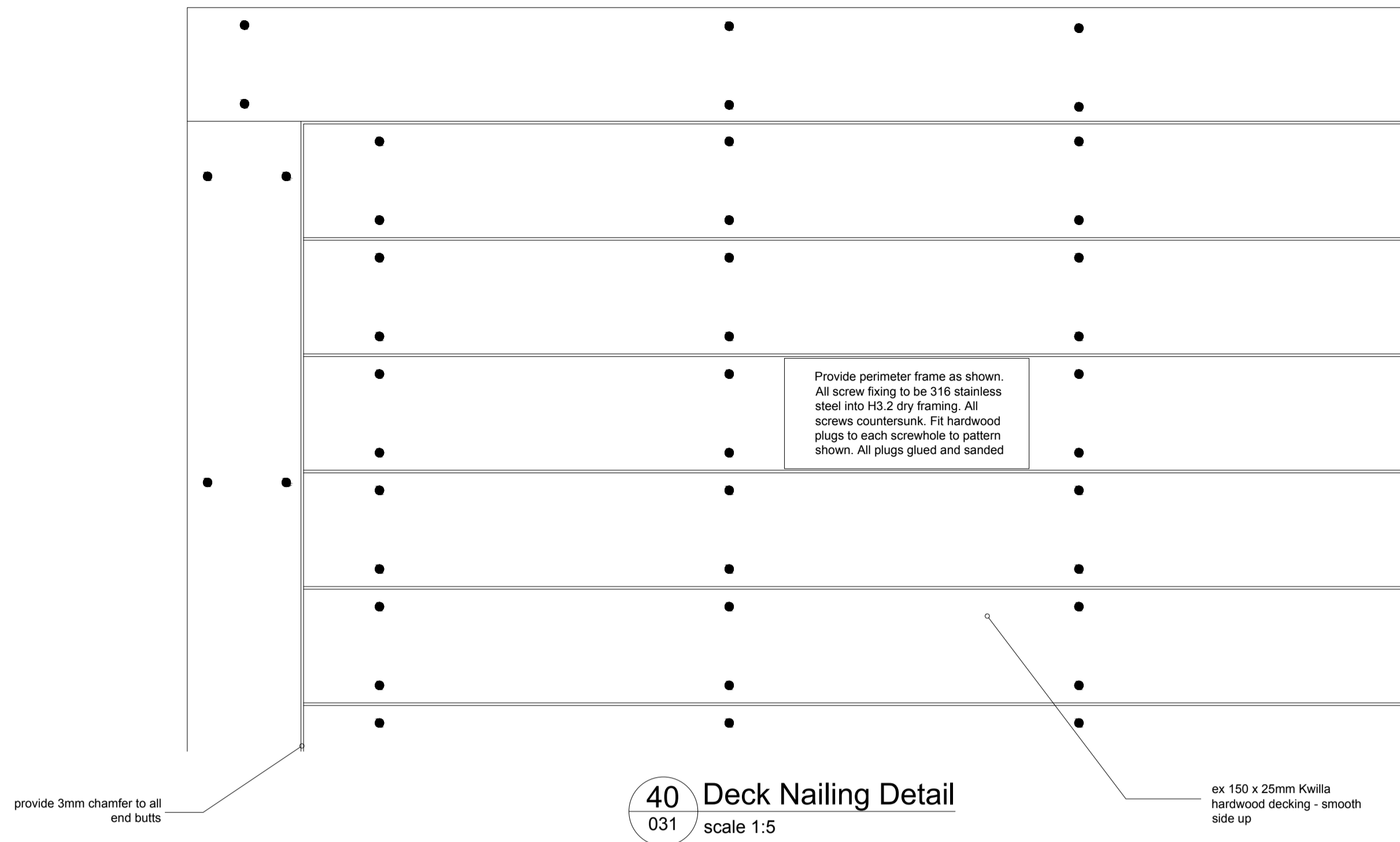

Revisions	General notes

NOTE:

**STAGE 2  
CONSENT**

59 ROSEBERRY AVE BIRKENHEAD AUCKLAND TEL (09)418 2432 FAX (09)419 5142

APARTMENT DEVELOPMENT  
81 Sarsfield Street, Herne Bay

**DELAMARE ARCHITECTS**

Date DEC'17  
Scale 1/5 @ A1  
Drawing Reference  
job no. SAR 031  
revision  
Cod ref SAR  
CADREF

USE DIMENSIONS: DO NOT SCALE FROM DRAWING. ALL LEVELS AND DIMENSIONS TO BE CHECKED ON SITE. DRAWING TO BE READ IN CONJUNCTION WITH ALL RELEVANT DOCUMENTS.  
©THE COPYRIGHT OF THIS DRAWING IS THE PROPERTY OF DAVID DELAMARE

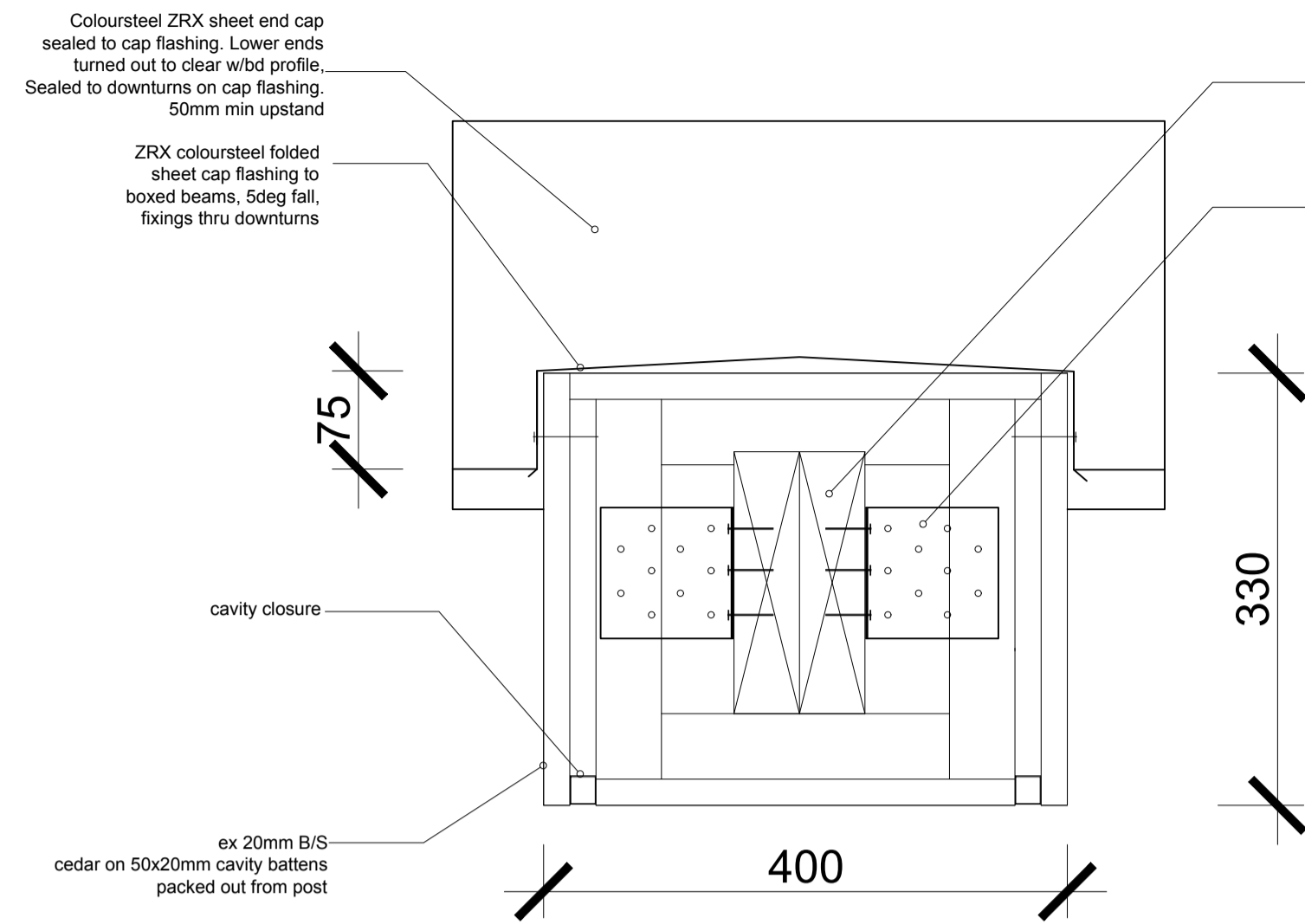

**46** Entry Beam/ pergola Detail  
032 scale 1:5

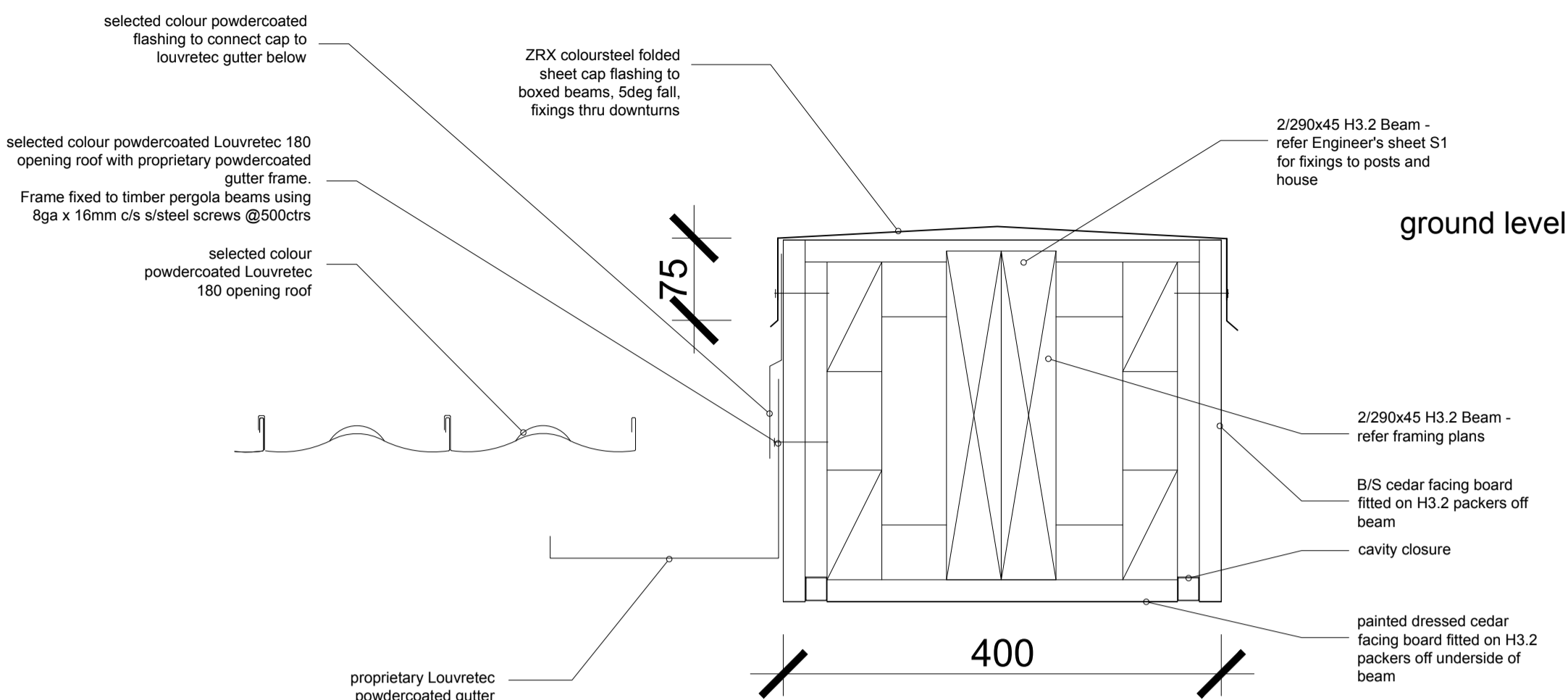

**47** Louvre Beam Detail  
032 scale 1:5

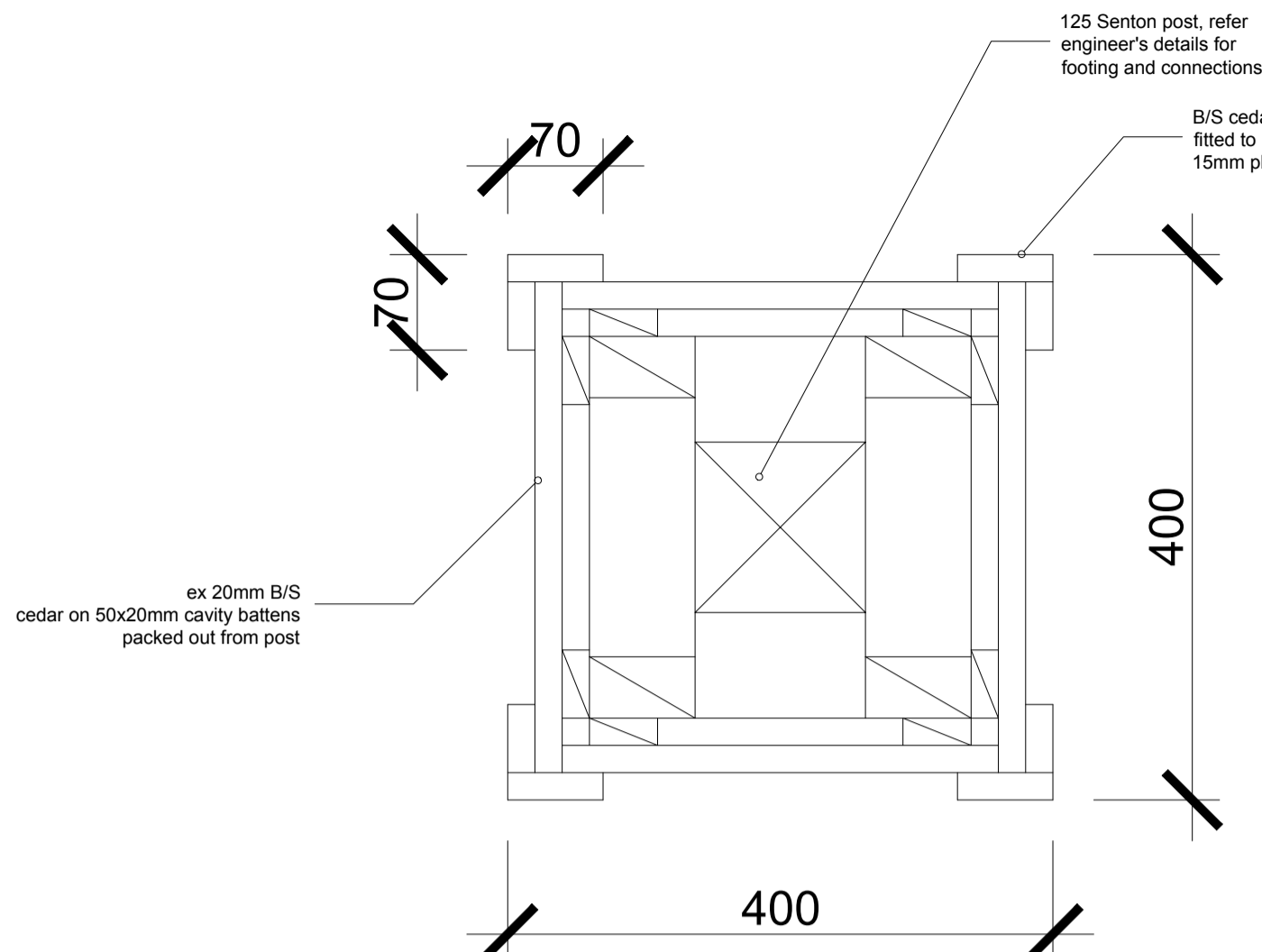

**48** Entry/Louvre Column Detail  
032 scale 1:5

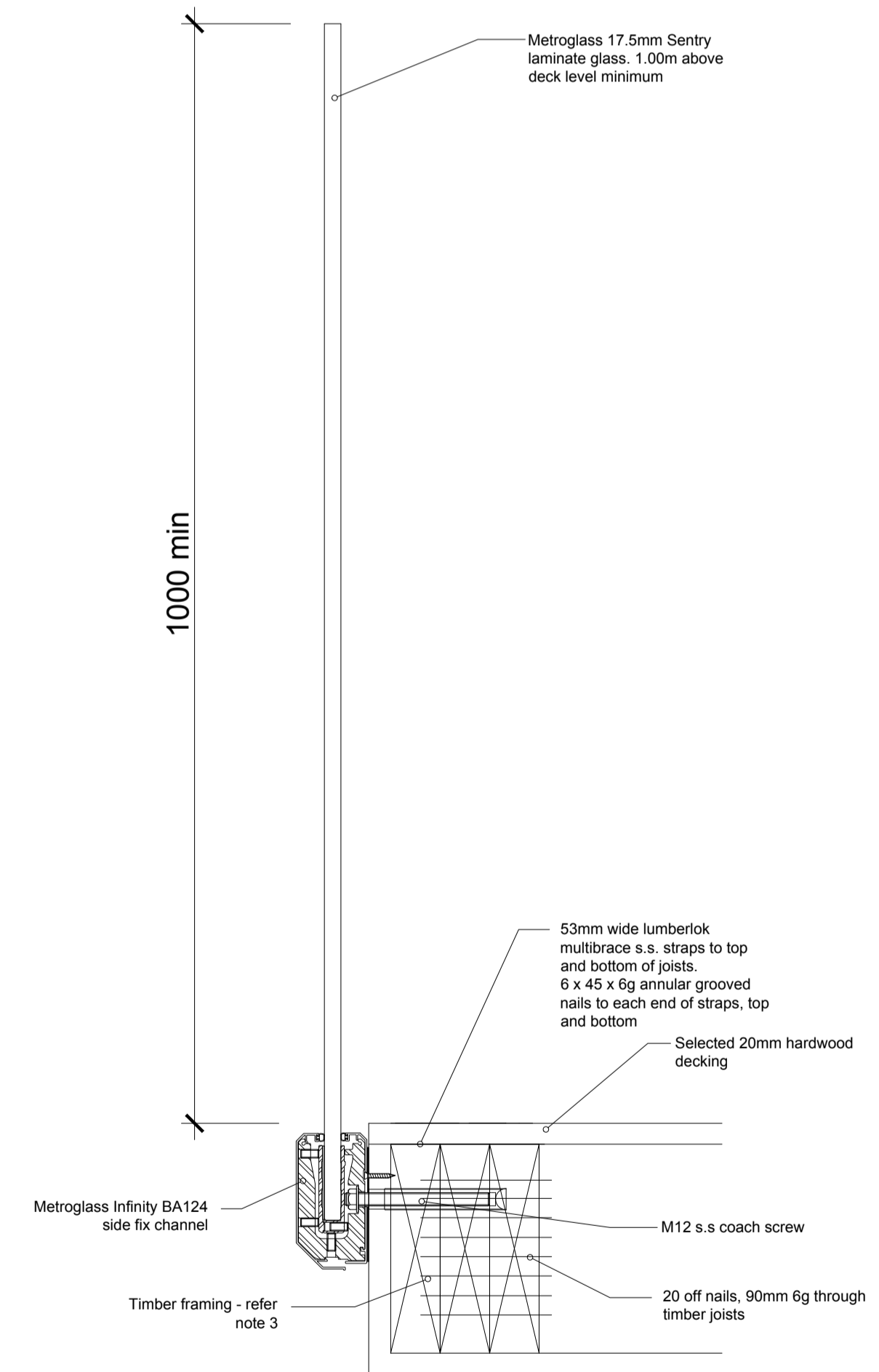

**49** Internal Balustrade Detail  
032 scale 1:5 METROGLASS RESIDENTIAL BALUSTRADE SYSTEM

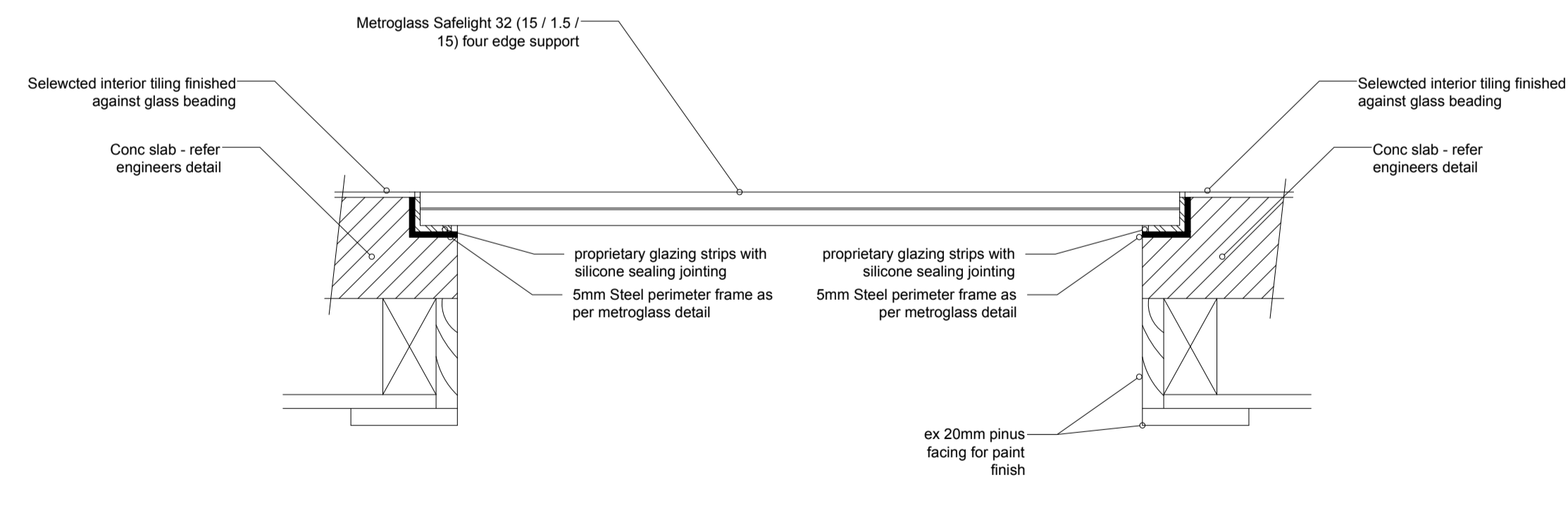

**50** Entry Glazing Detail  
032 scale 1:5

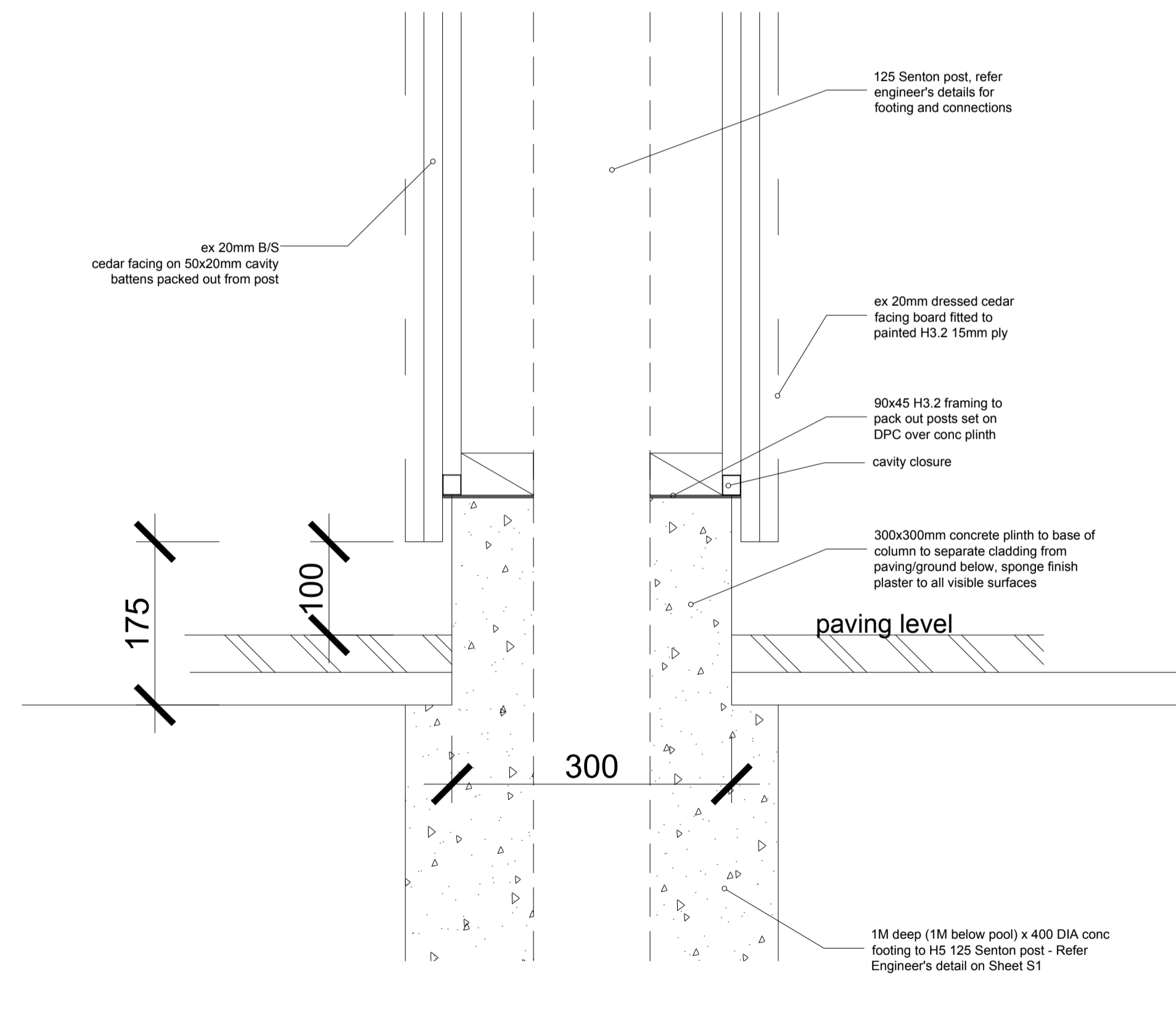

**51** Entry/Louvre Column Elevation  
032 scale 1:5

Revisions	General notes

NOTE:  
**STAGE 2  
CONSENT**

59 ROSEBERRY AVE BIRKENHEAD AUCKLAND TEL (09)418 2432 FAX (09)419 5142  
 APARTMENT DEVELOPMENT  
 81 SANSFIELD STREET, HERNE BAY

**DELAMARE ARCHITECTS**

Date DEC'17  
 Scale 1/5 @ A1  
 Drawing Reference  
 Job no SAR 032  
 Revision  
 Cad ref SAR  
 CADREF

USE POURED DIMENSIONS. DO NOT SCALE FROM DRAWING. ALL LEVELS AND DIMENSIONS TO BE CHECKED ON SITE. DRAWING TO BE READ IN CONJUNCTION WITH ALL RELEVANT DOCUMENTS. ©THE COPYRIGHT OF THIS DRAWING IS THE PROPERTY OF DAVID DELAMARE



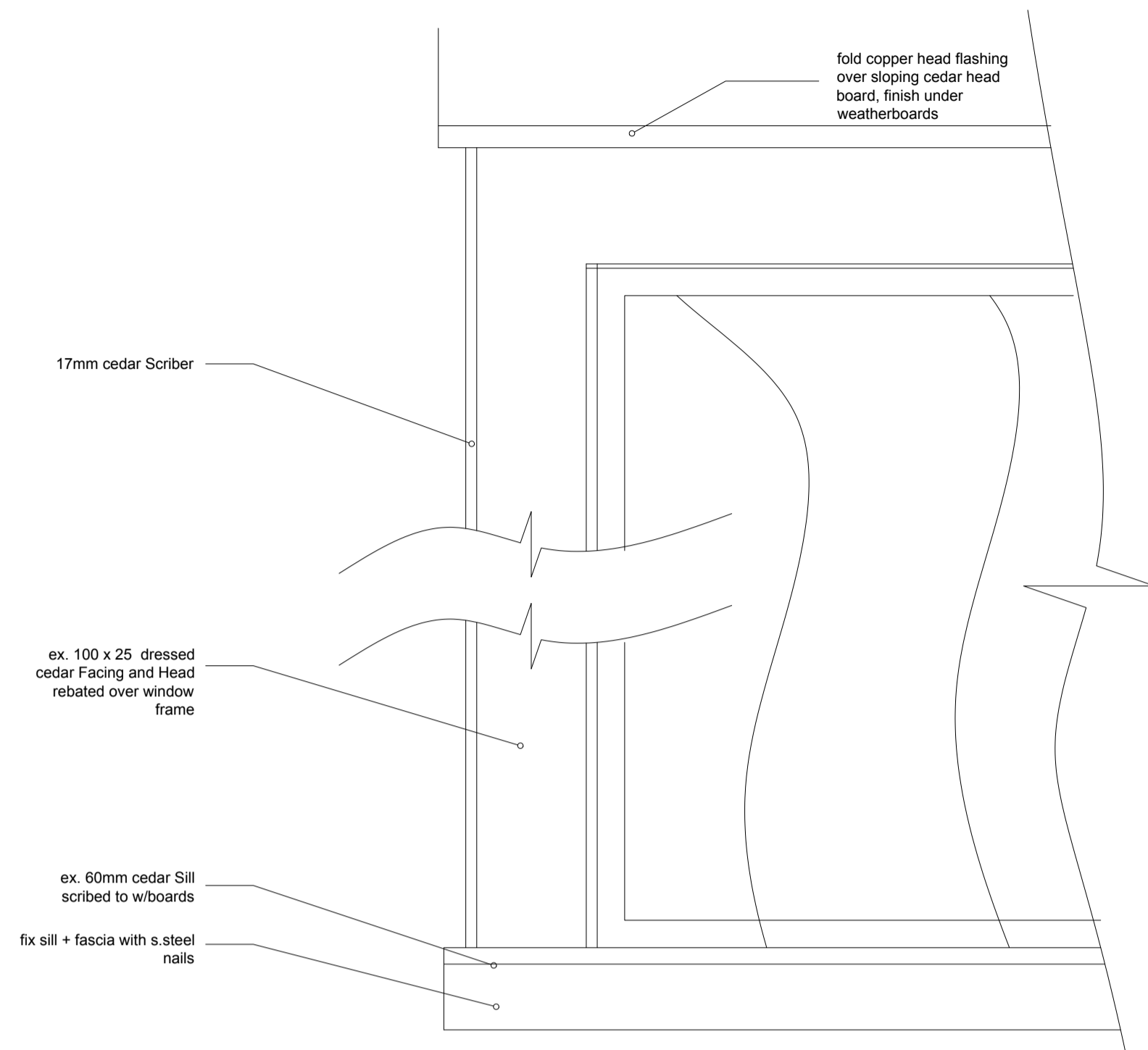

**51** Joinery Facing Elevation  
033 scale 1:5

All exterior frames

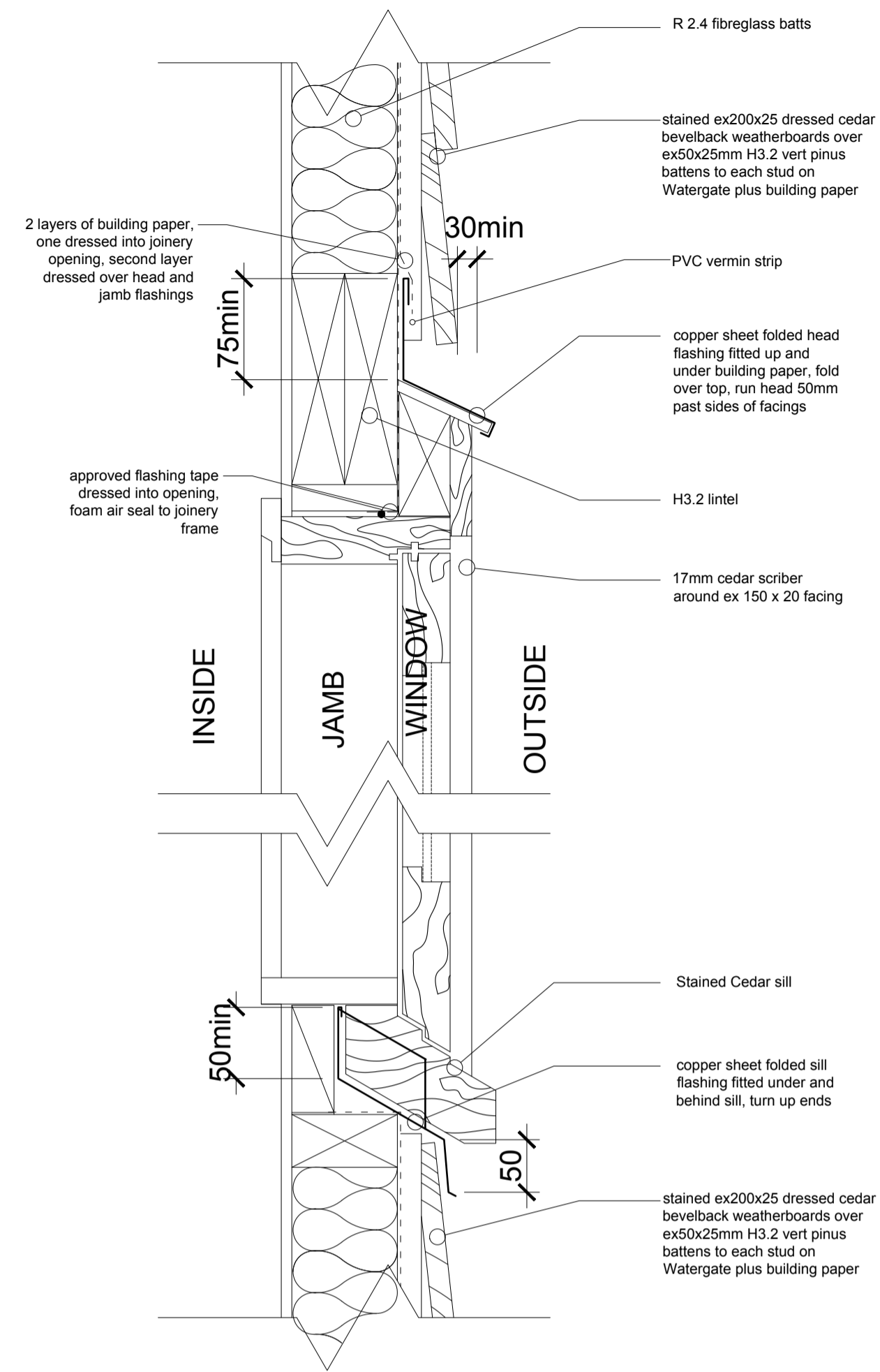

**52** Window head & sill  
033 scale 1:5

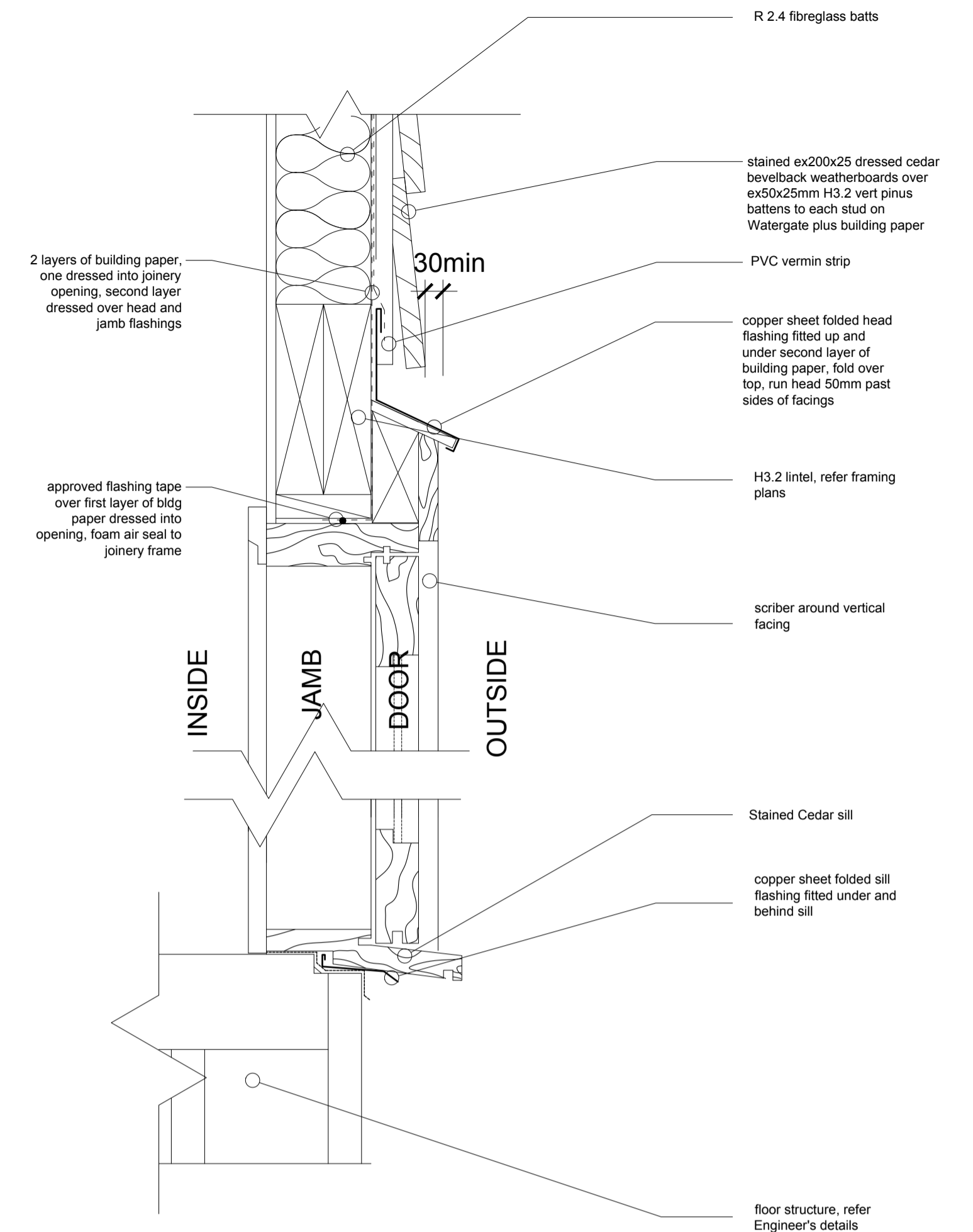

**53** Door head & sill  
033 scale 1:5

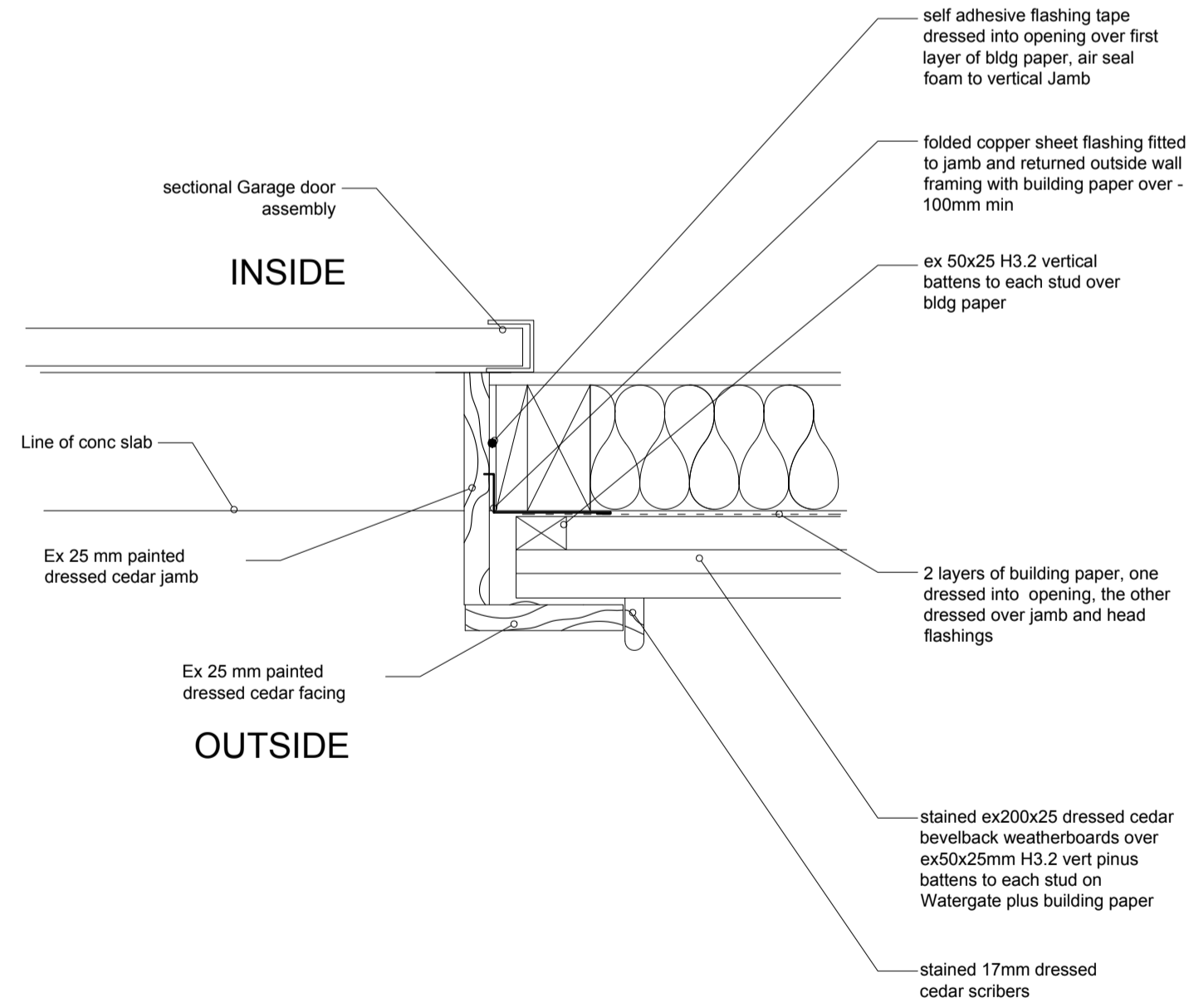

**54** Garage Door Jamb Detail  
033 scale 1:5 (PLAN)

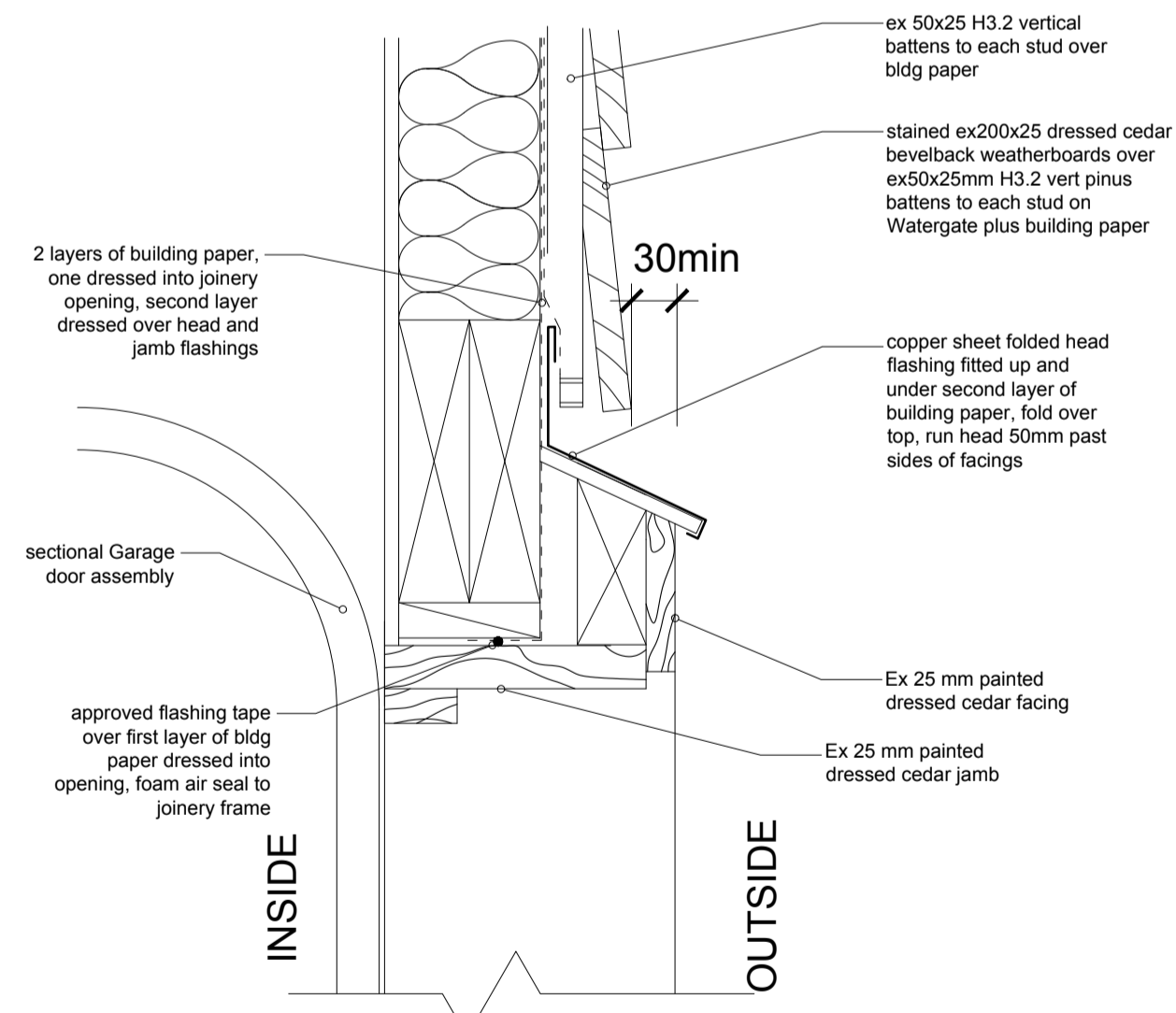

**55** Garage Door head  
033 scale 1:5

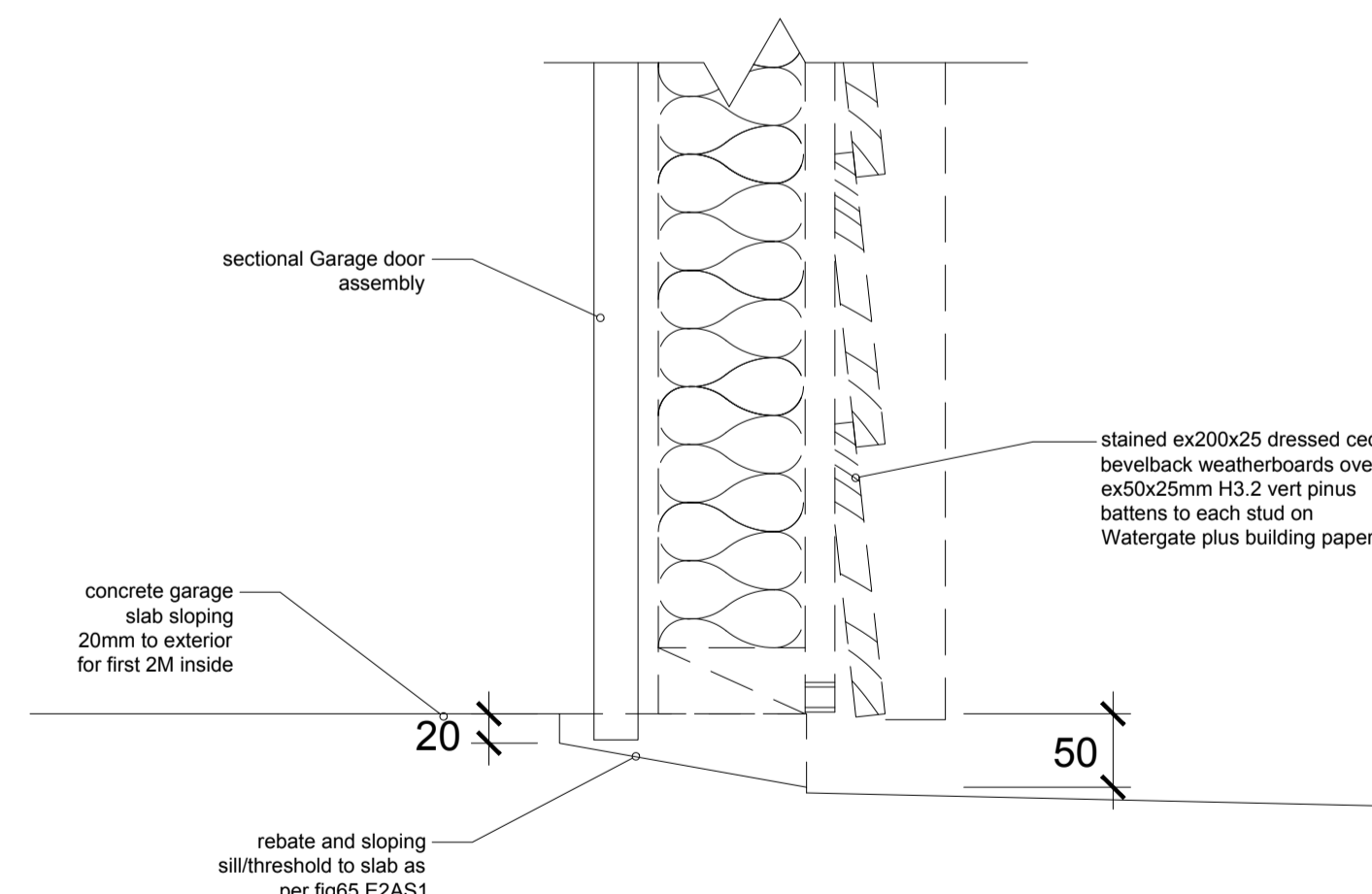

**56** Garage Door Sill  
033 scale 1:5

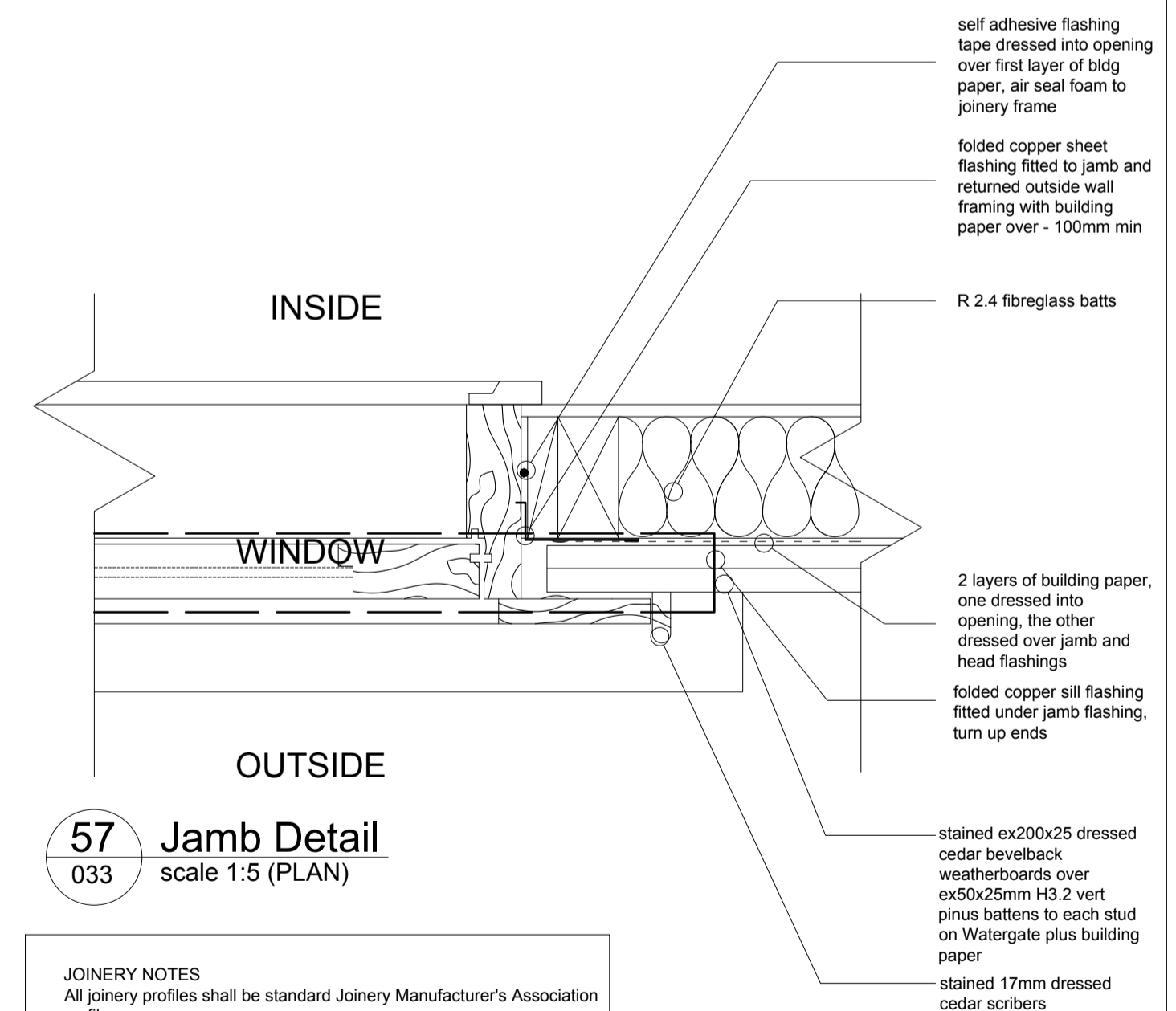

**57** Jamb Detail  
033 scale 1:5 (PLAN)

**JOINERY NOTES**  
All joinery profiles shall be standard Joinery Manufacturer's Association profiles  
Sashes Cedar - Frames Pinus H3.2 FJ for paint finish

Revisions	General notes

NOTE:

**STAGE 2  
CONSENT**

59 ROSEBERRY AVE BIRKENHEAD AUCKLAND TEL (09)418 2432 FAX (09)419 5142

APARTMENT DEVELOPMENT  
81 SARSFIELD STREET, HERNE BAY

**DELAMARE  
ARCHITECTS**

DETAILS

Drawing Reference

job no: SAR 033

Date DEC'17

Scale 1/5 @ A1

revision

CADREF

USE SQUARE DIMENSIONS. DO NOT SCALE FROM DRAWING.  
ALL LEVELS AND DIMENSIONS TO BE CHECKED ON SITE.  
DRAWING TO BE READ IN CONJUNCTION WITH ALL  
RELEVANT DOCUMENTS.  
©THE COPYRIGHT OF THIS DRAWING IS THE PROPERTY  
OF DAVID DELAMARE

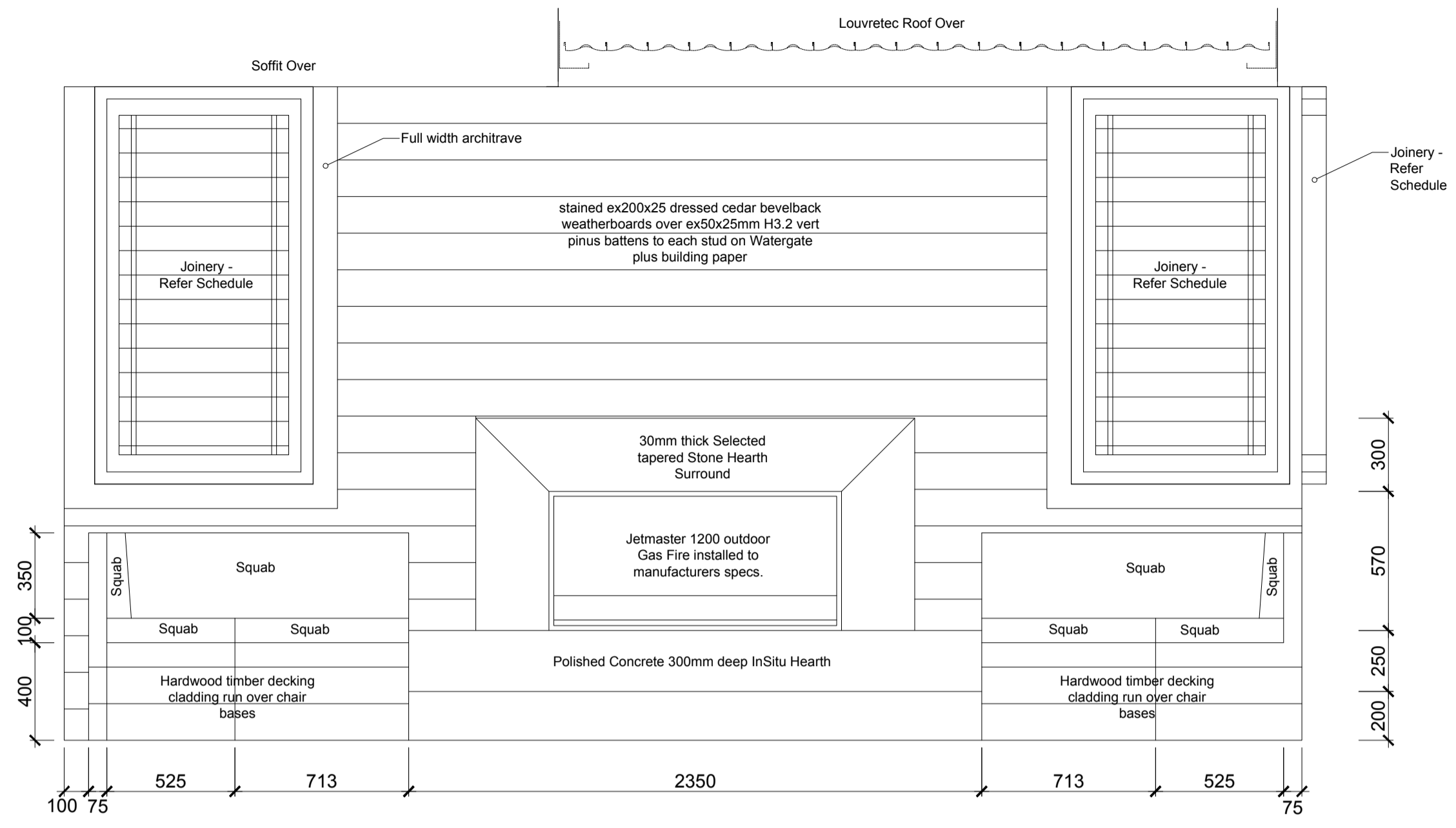

Apartment 1 - Outside Fireplace  
scale 1:20

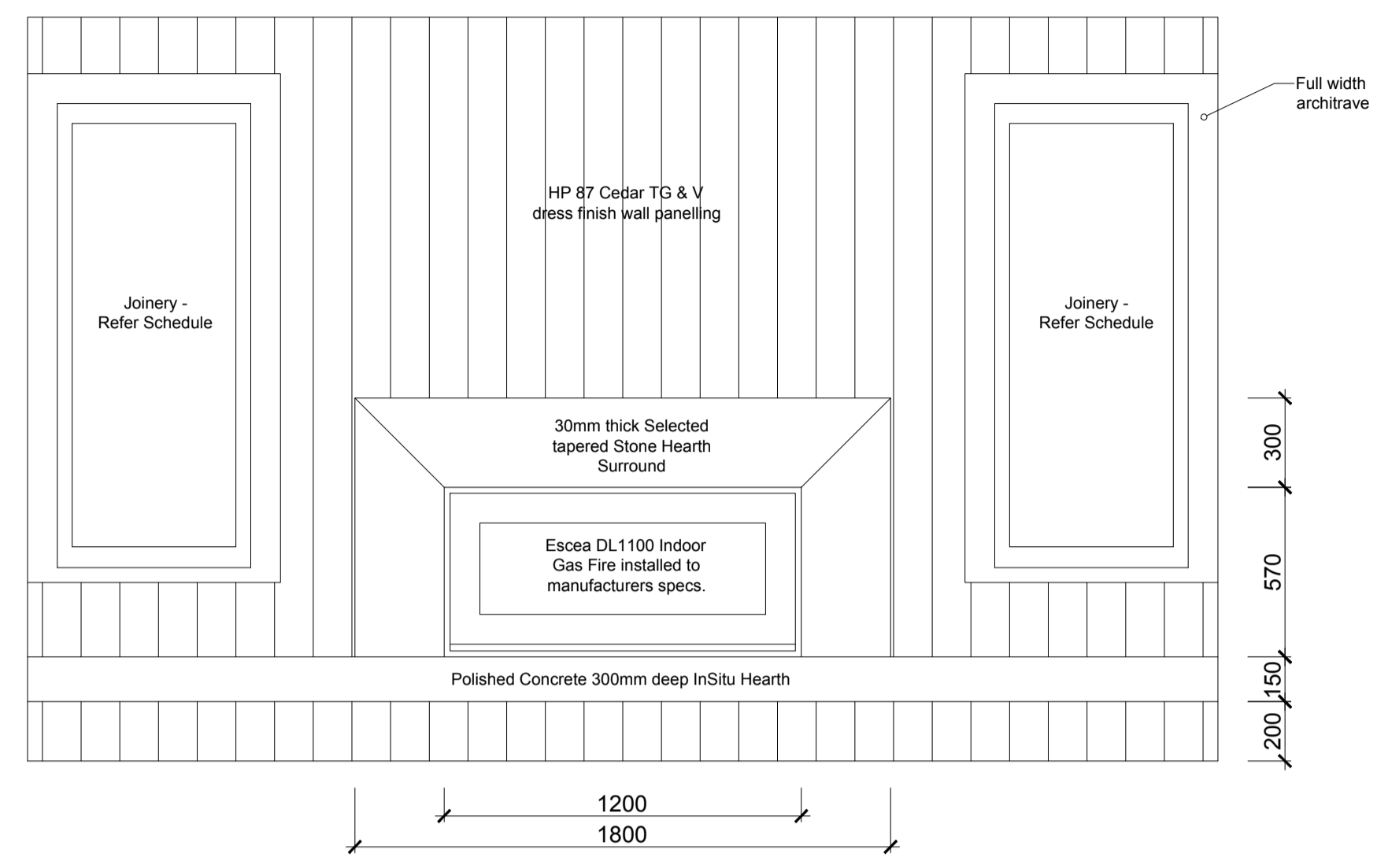

Apartment 1 - Living Room Fireplace  
scale 1:20

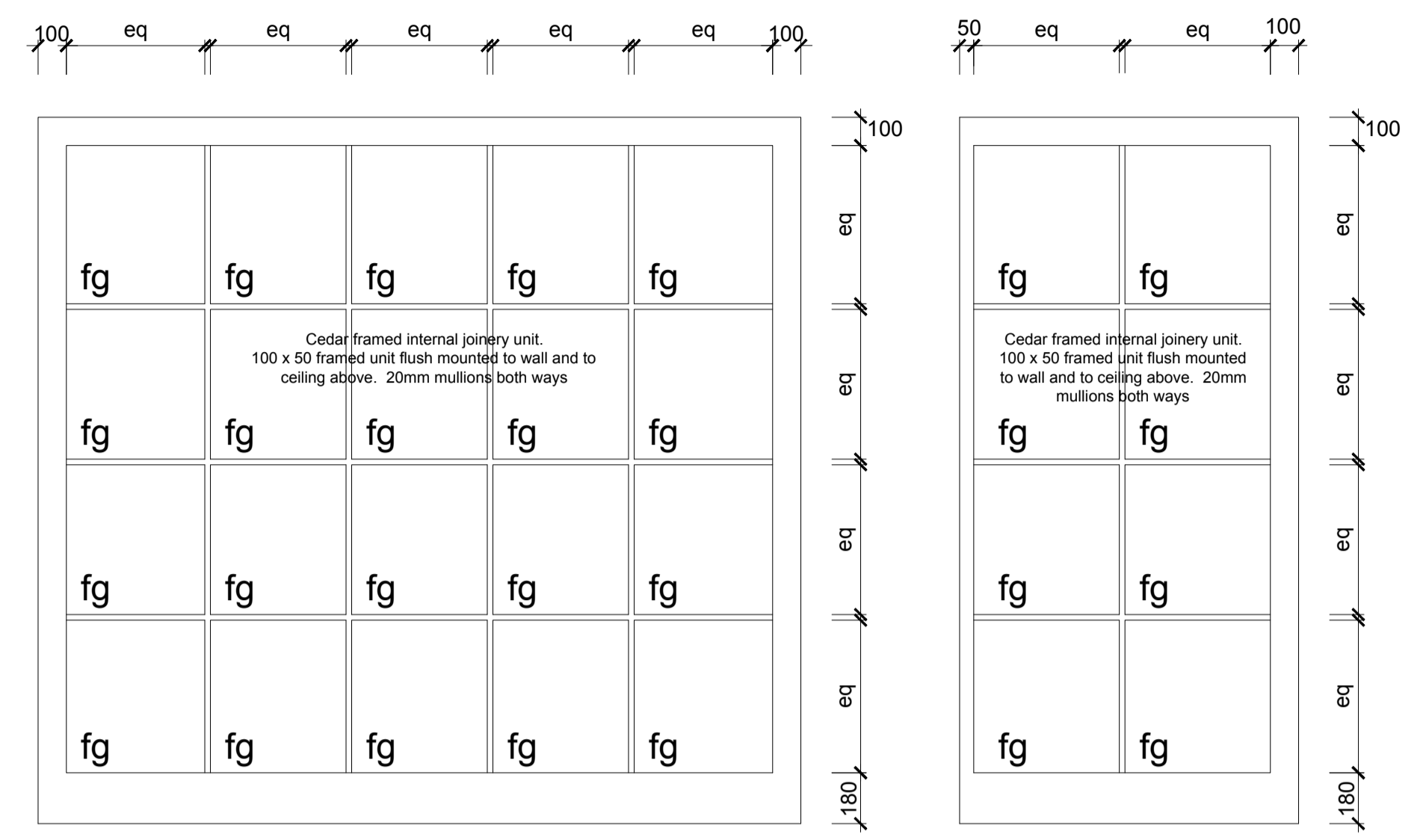

Den wall partition  
scale 1:20

Kitchen wall partition  
scale 1:20

**IMPORTANT**  
Confirm all Joinery dimensions on site prior to manufacture

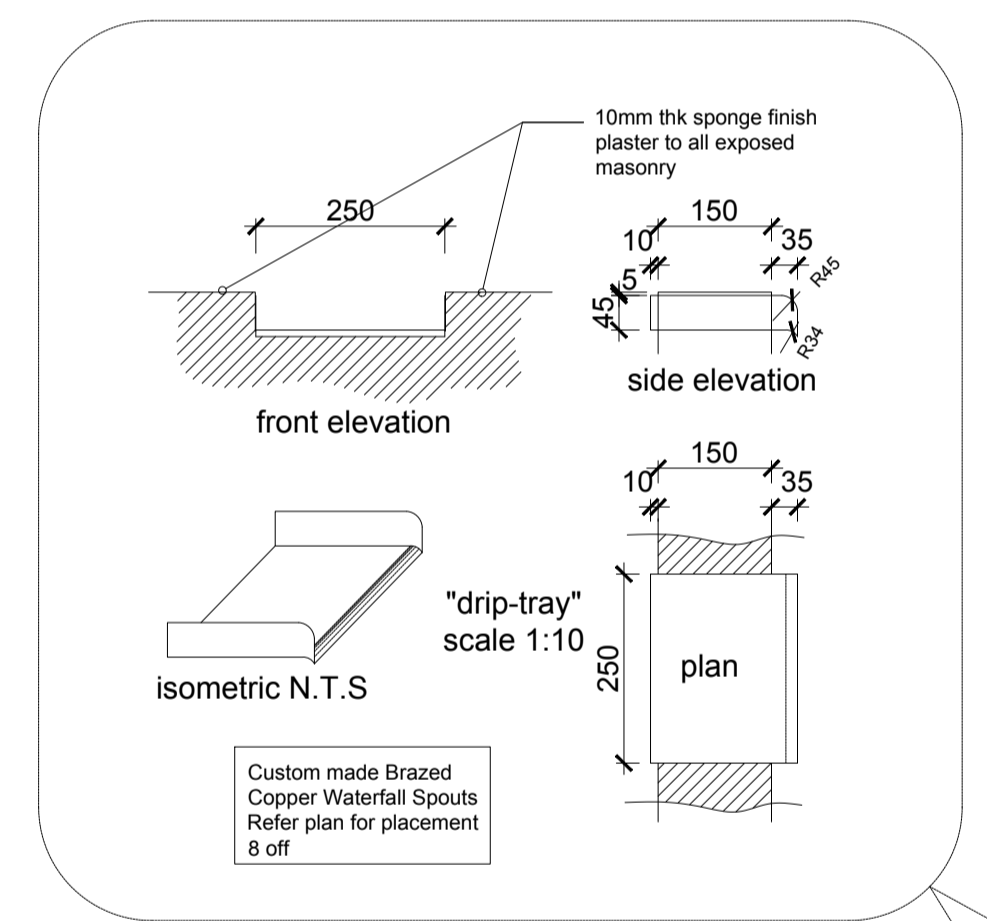

Water Feature Detail  
scale 1:20 Refer engineers drawings for all footing, retaining and slab details

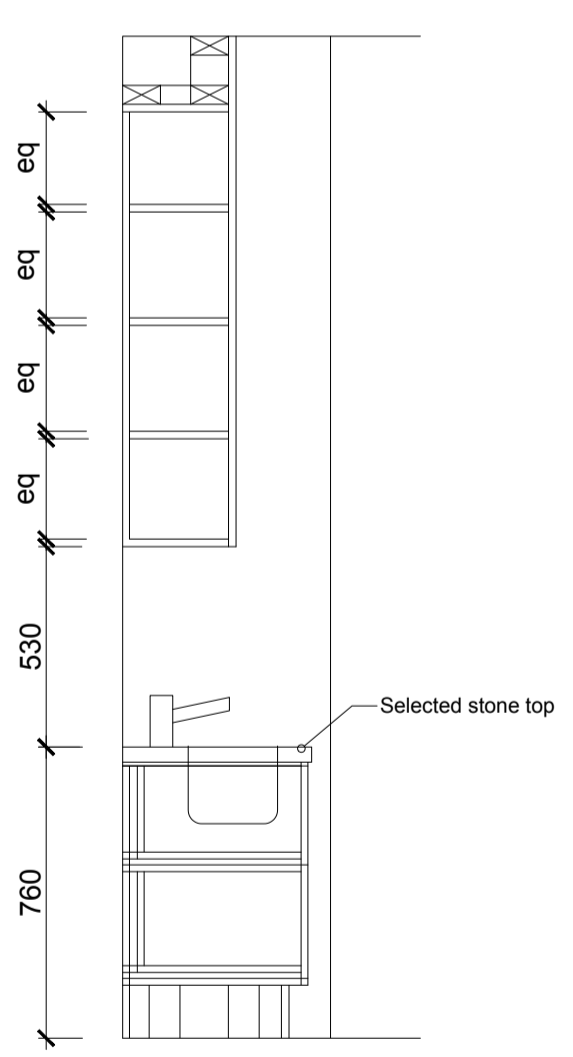
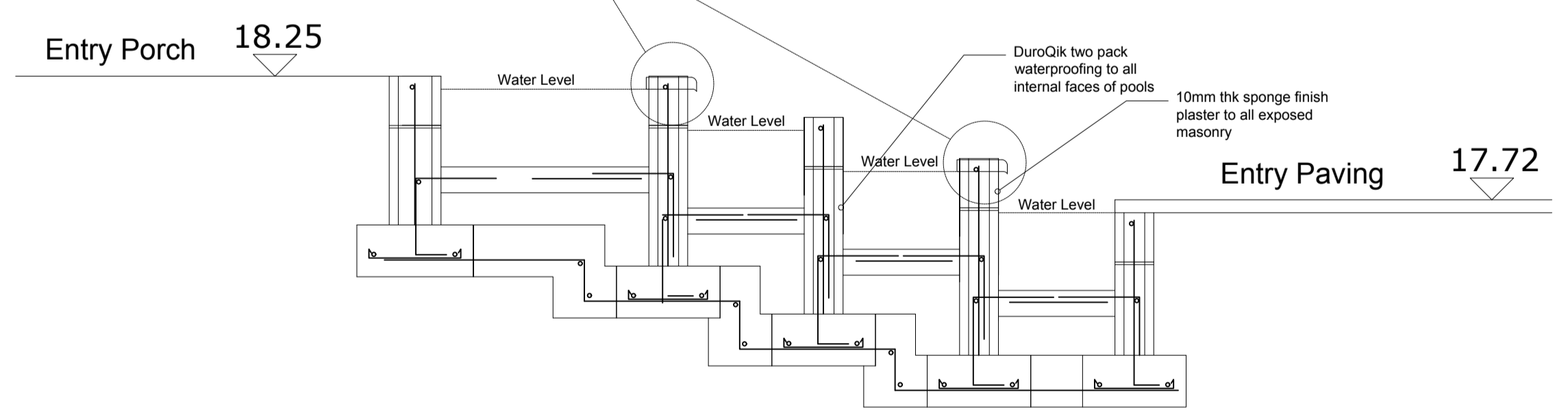

Workstation - Section  
scale 1:20

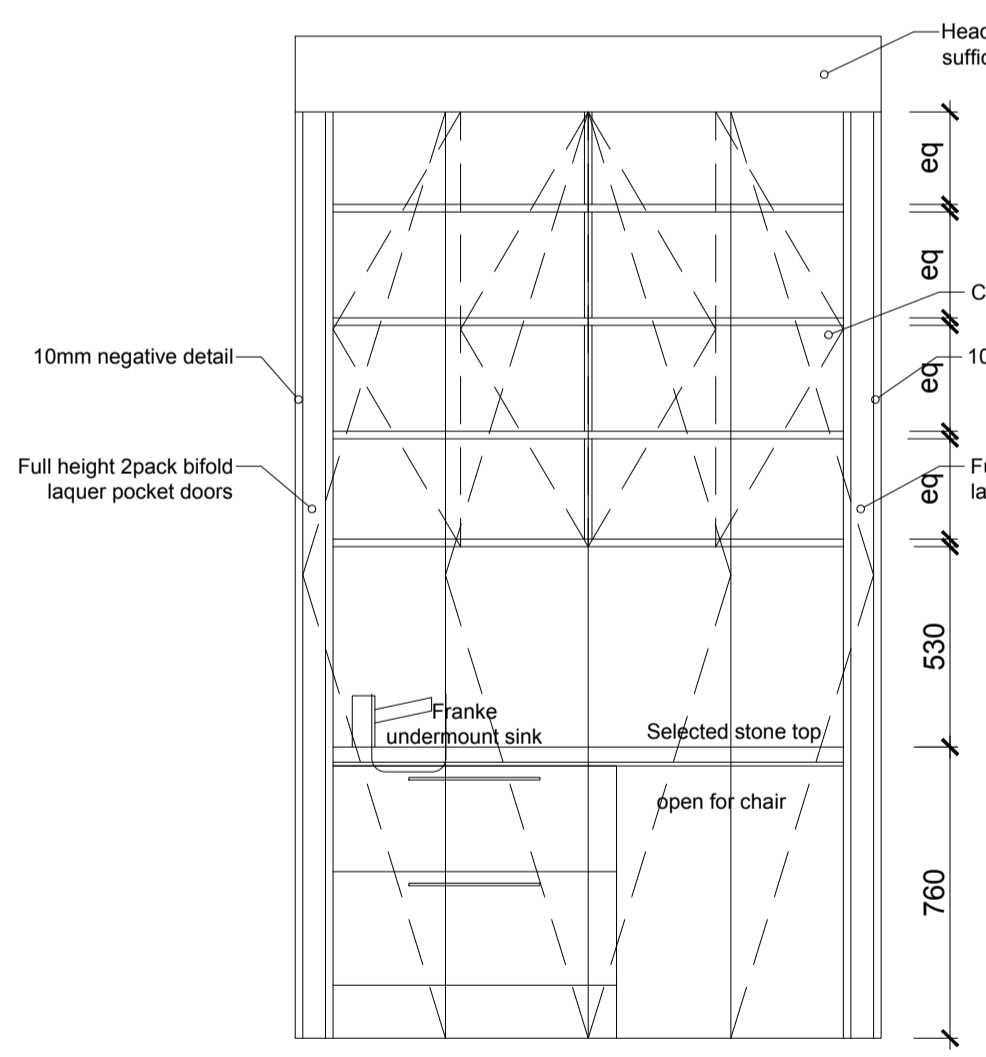

Apartment 1 - Workstation  
scale 1:20

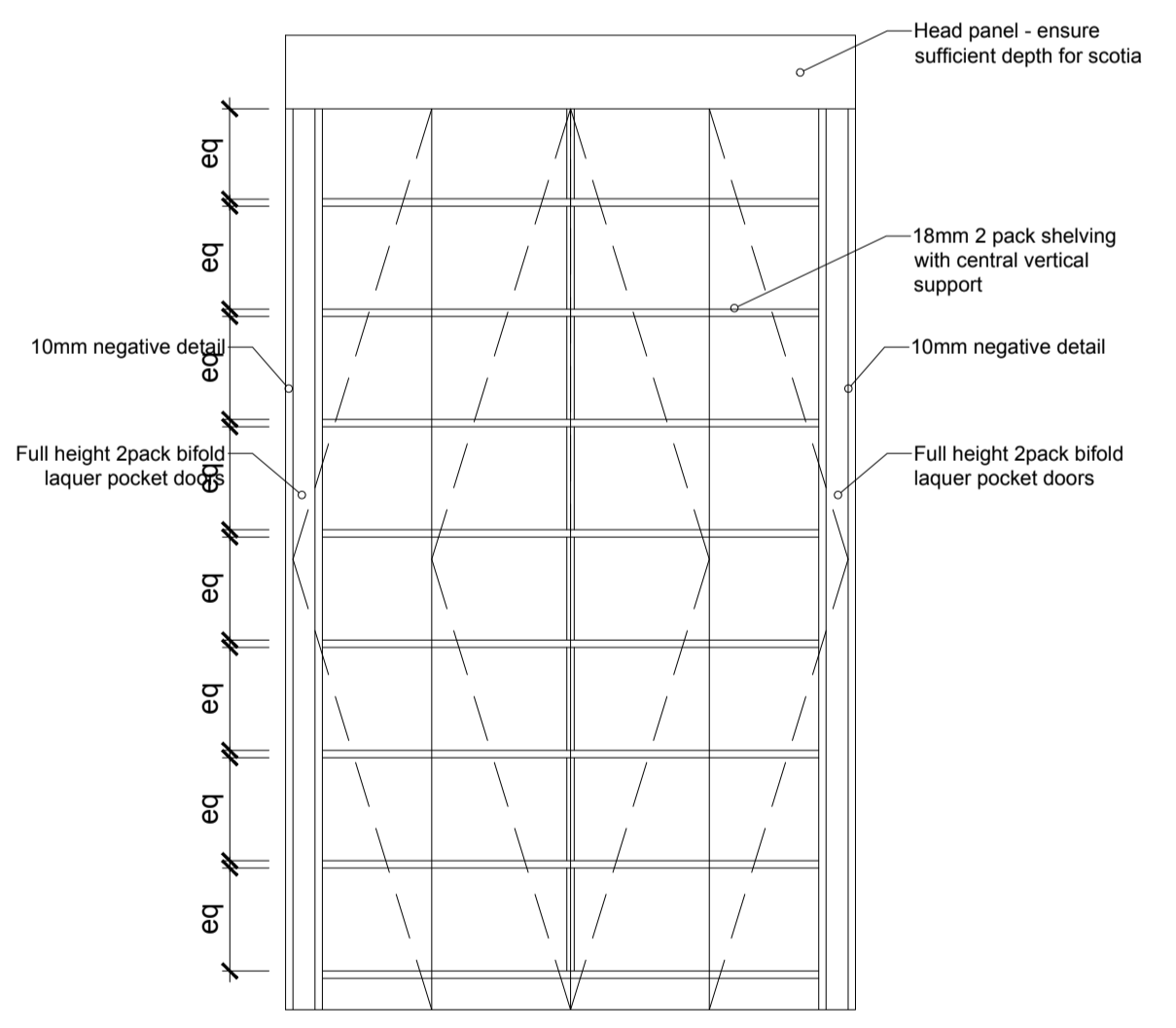

Apartment 1 - Storage  
scale 1:20

Revisions	General notes

NOTE:  
**STAGE 2  
CONSENT**

59 ROSEBERRY AVE BIRKENHEAD AUCKLAND TEL (09)418 2432 FAX (09)419 5142  
**APARTMENT DEVELOPMENT**  
 81 SANSFIELD STREET, HERNE BAY

**DELAMARE ARCHITECTS**

Date DEC'17  
 Scale 1/20 @ A1  
 Drawing Reference  
 APARTMENT 1 FITTINGS  
 Job no SAR  
 Des no 034  
 Revision  
 Cad ref SAR  
 CADREF

USE DIMENSIONS. DO NOT SCALE FROM DRAWING.  
 ALL LEVELS AND DIMENSIONS TO BE CHECKED ON SITE.  
 DRAWING TO BE READ IN CONJUNCTION WITH ALL RELEVANT DOCUMENTS.  
 THE CONTENT OF THIS DRAWING IS THE PROPERTY OF DAVID DELAMARE

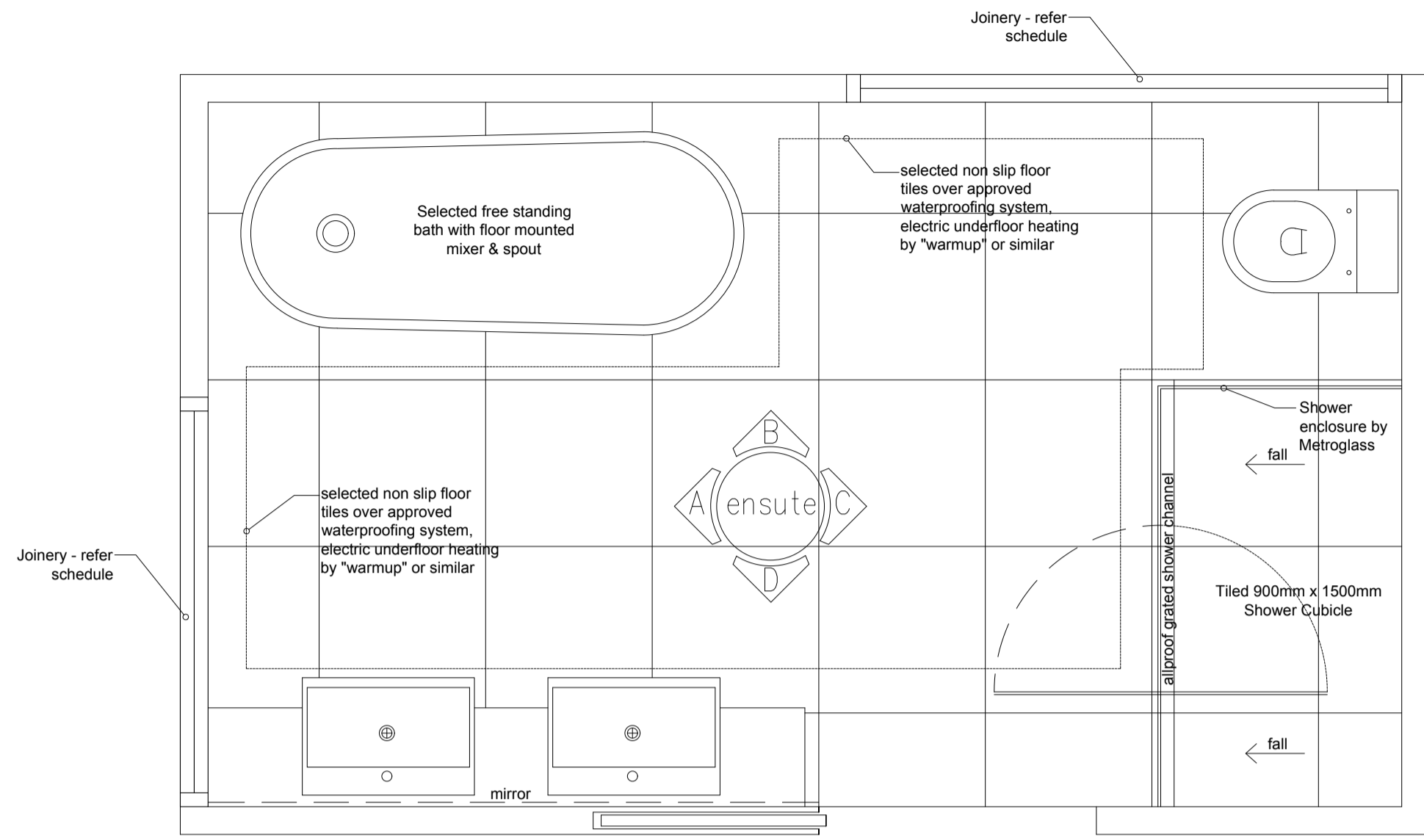

**Master Ensuite - Apartment 1**  
 bthrm scale 1:20

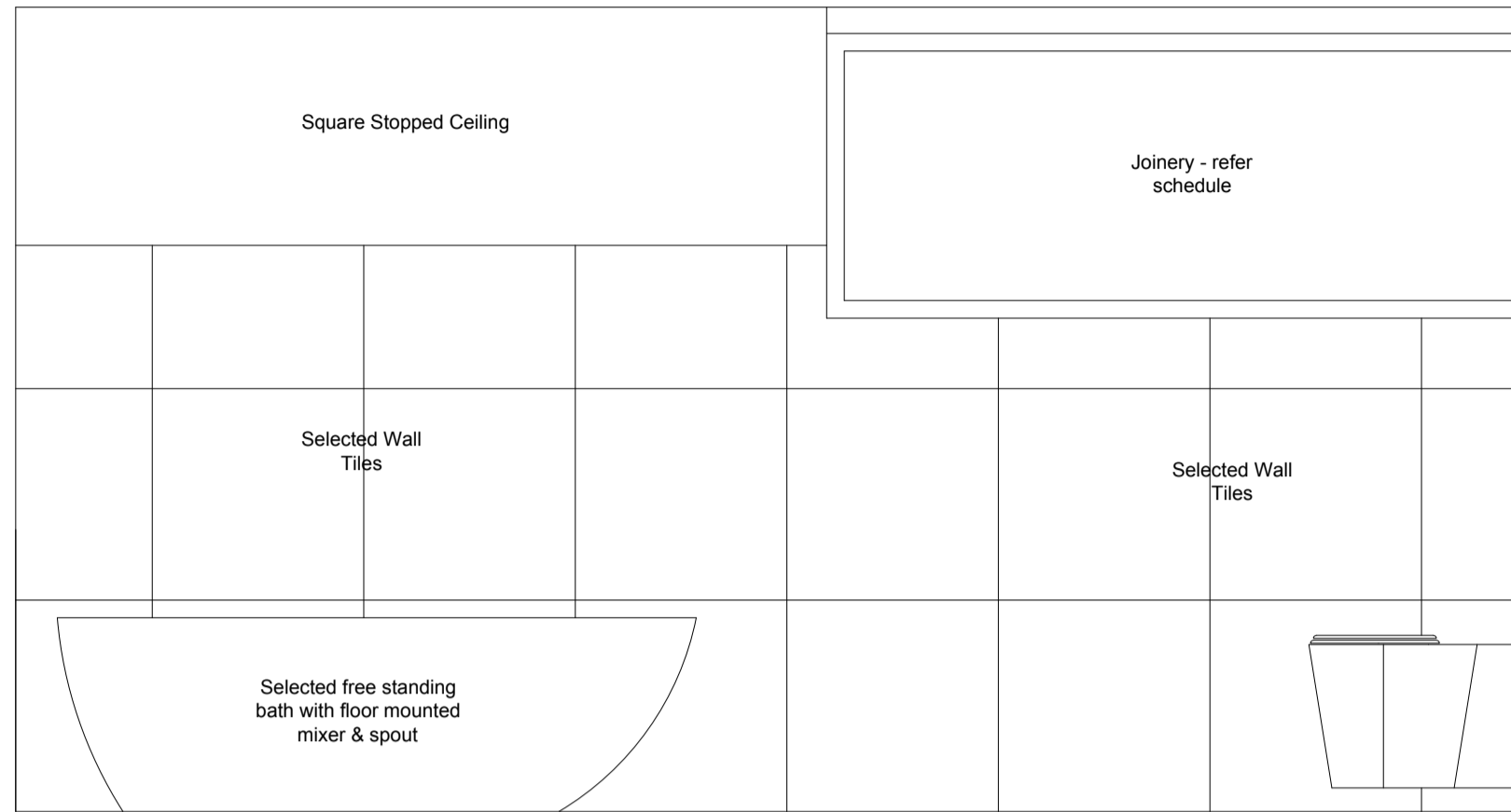

**Master Ensuite - Elevation D**  
 bthrm scale 1:20

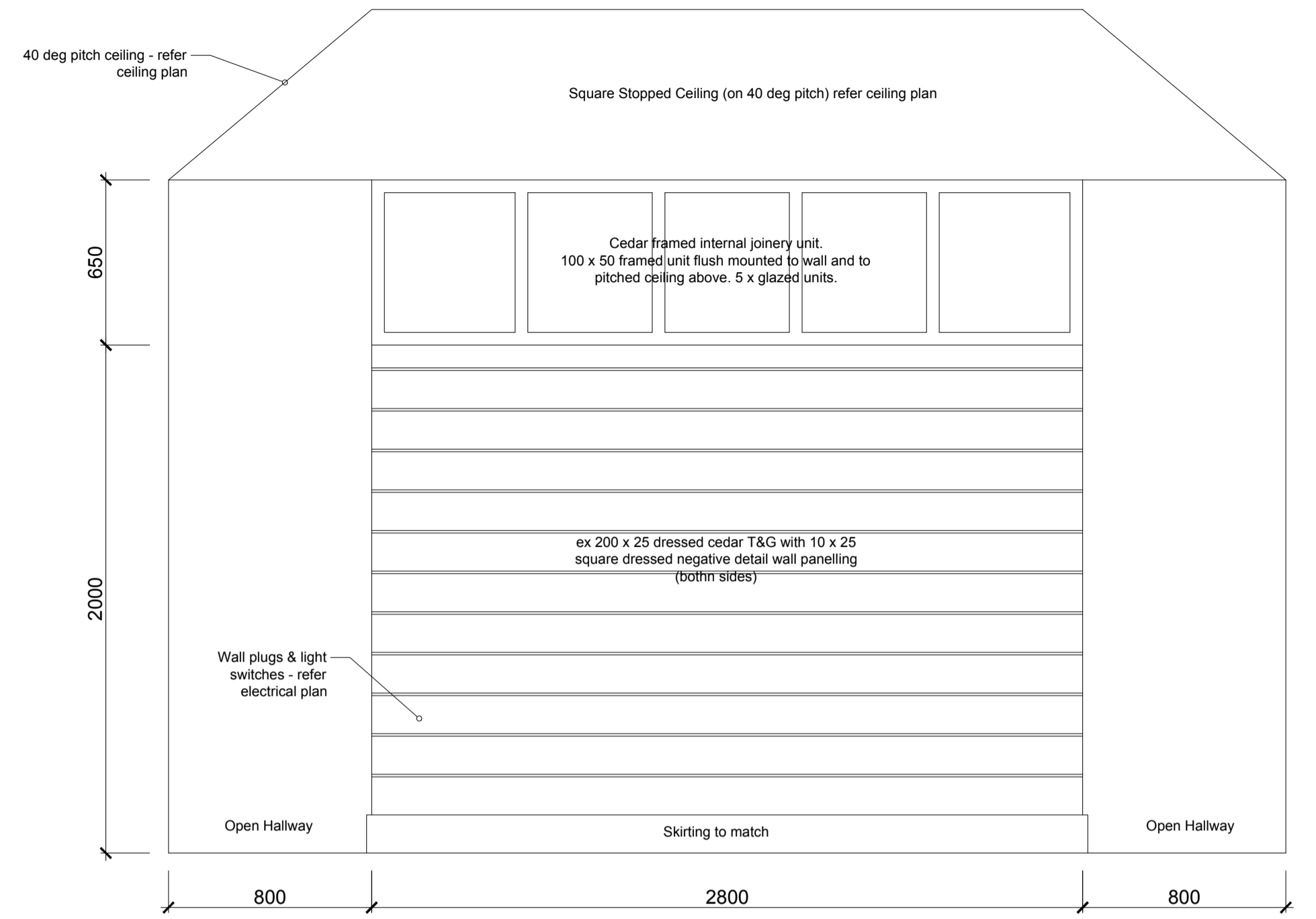

**Master Bedroom - Bed Head**  
 scale 1:20

**IMPORTANT**  
 Confirm all Joinery dimensions on site prior to manufacture

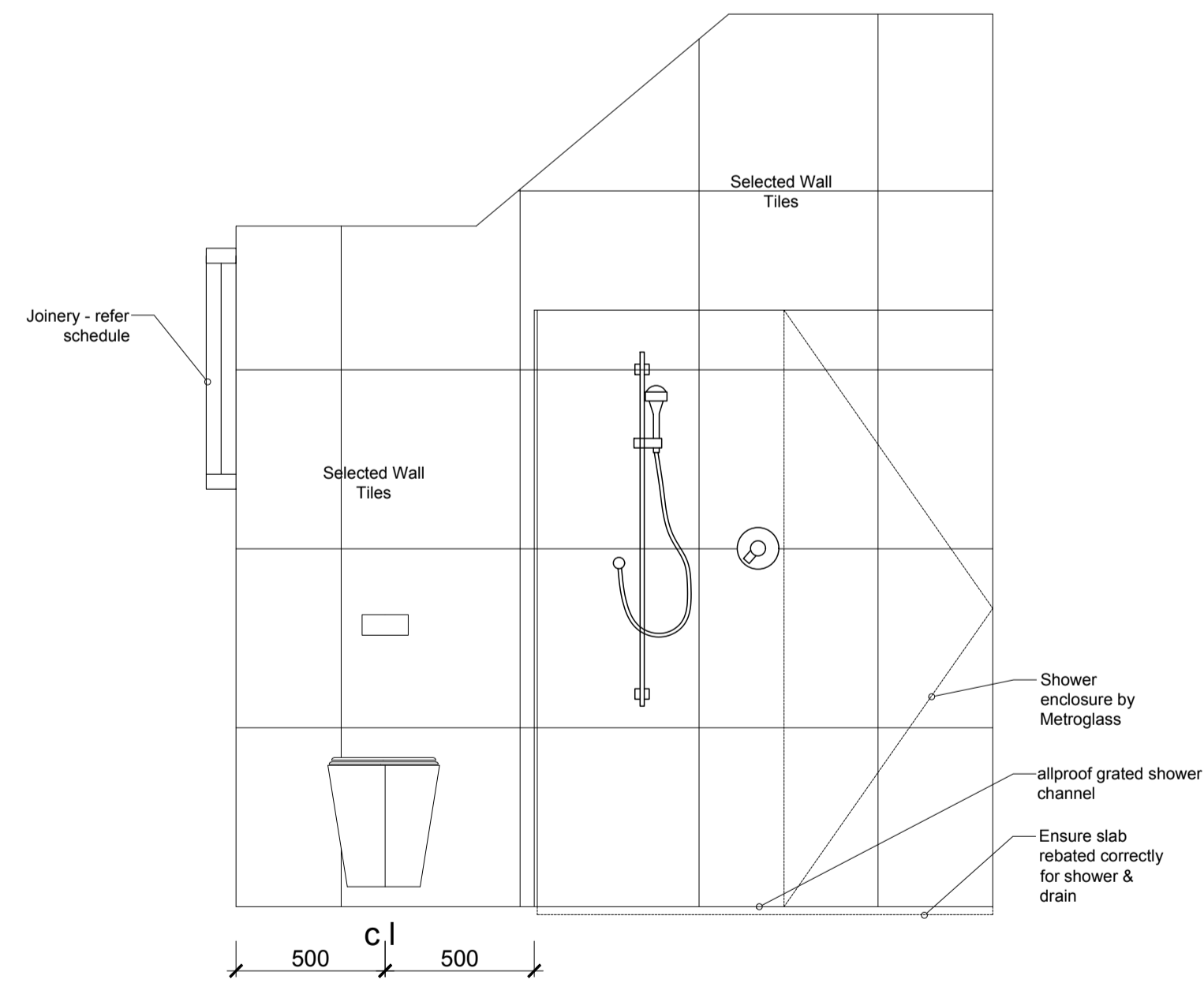

**Master Ensuite - Elevation A**  
 bthrm scale 1:20

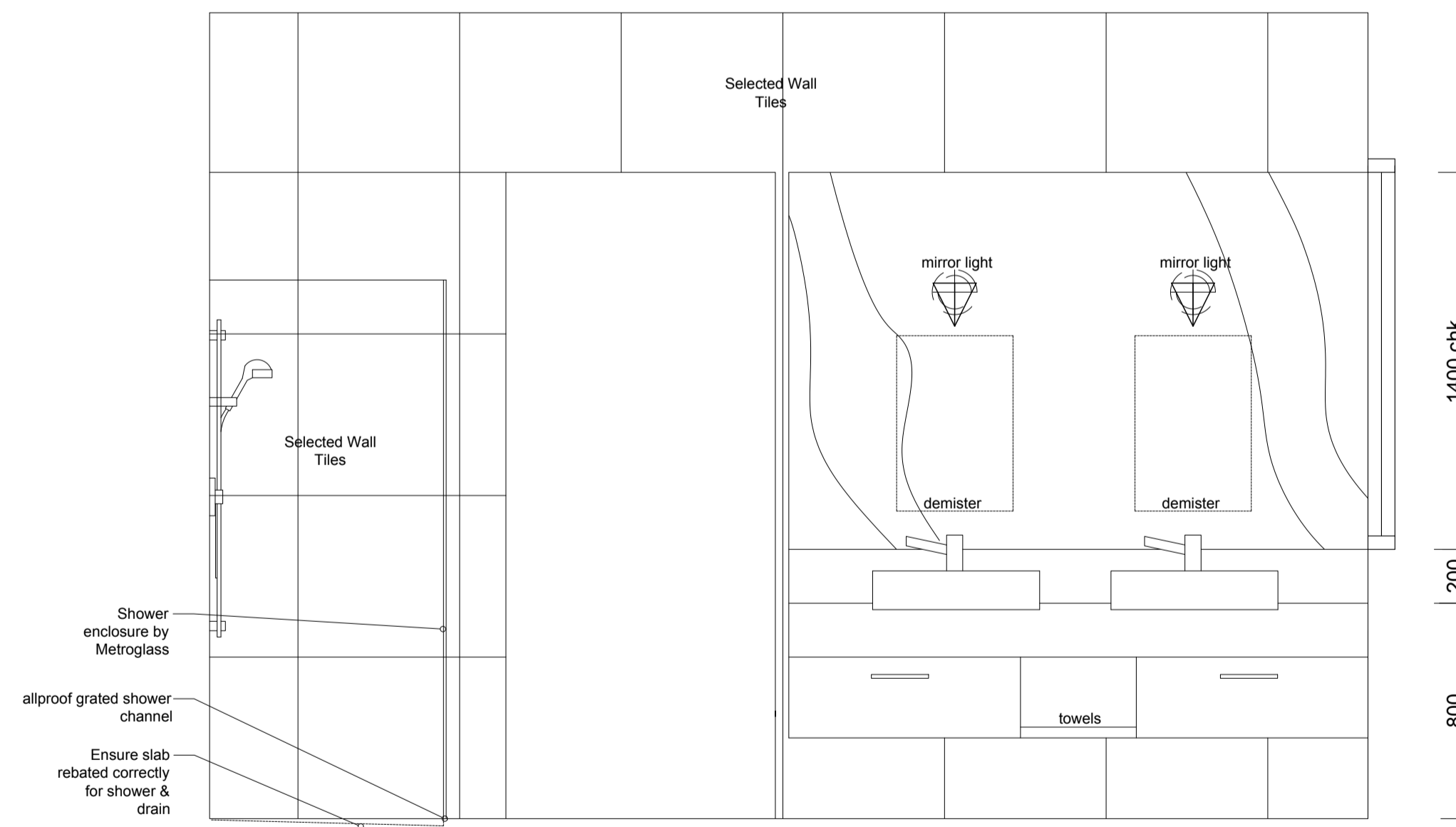

**Master Ensuite - Elevation B**  
 bthrm scale 1:20

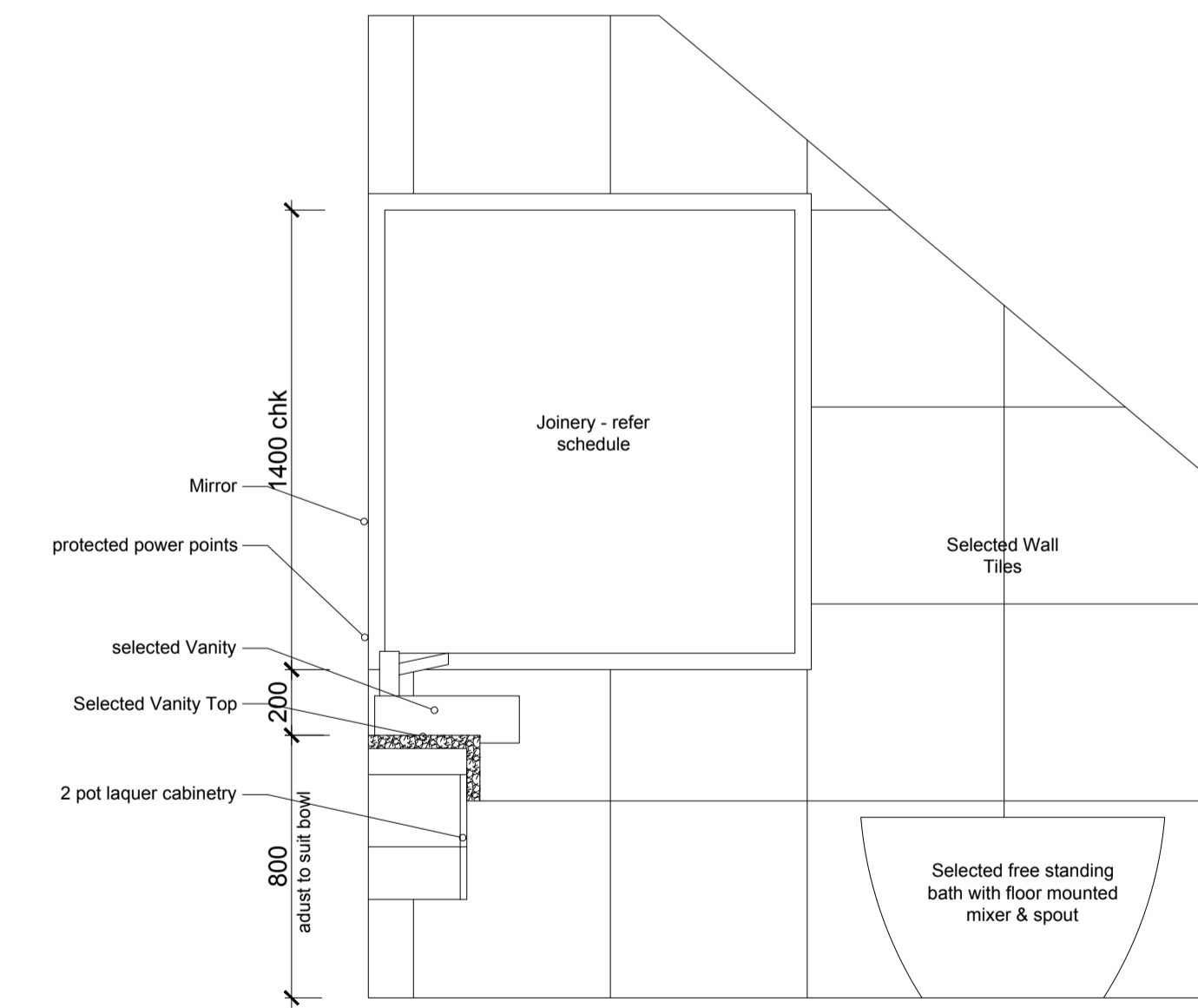

**Master Ensuite - Elevation C**  
 bthrm scale 1:20

Revisions	General notes

NOTE:  
**STAGE 2**  
**CONSENT**

59 ROSEBERRY AVE BIRKENHEAD AUCKLAND TEL (09)418 2432 FAX (09)419 5142  
 APARTMENT DEVELOPMENT  
 81 SANSFIELD STREET, HERNE BAY

**DELAMARE ARCHITECTS**

APARTMENT 1 MASTER ENSUITE  
 Drawing Reference: SAR 035  
 Date: DEC'17  
 Scale: 1/20 @ A1  
 Job no: SAR  
 Dep no: 035  
 Revision: CADREF

USE DIMENSIONS TO BE CHECKED ON SITE. DRAWING TO BE READ IN CONJUNCTION WITH ALL RELEVANT DOCUMENTS. ©THE COPYRIGHT OF THIS DRAWING IS THE PROPERTY OF DAVID DELAMARE.

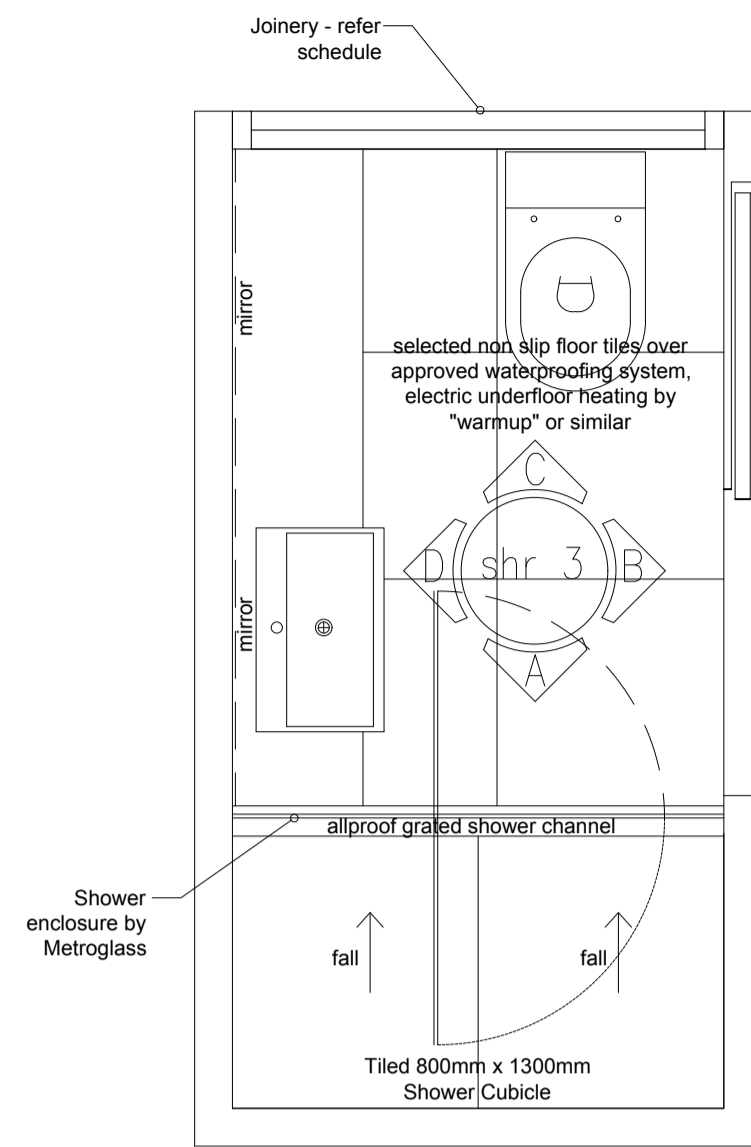

**Shower Room 3**  
scale 1:20  
bthrm

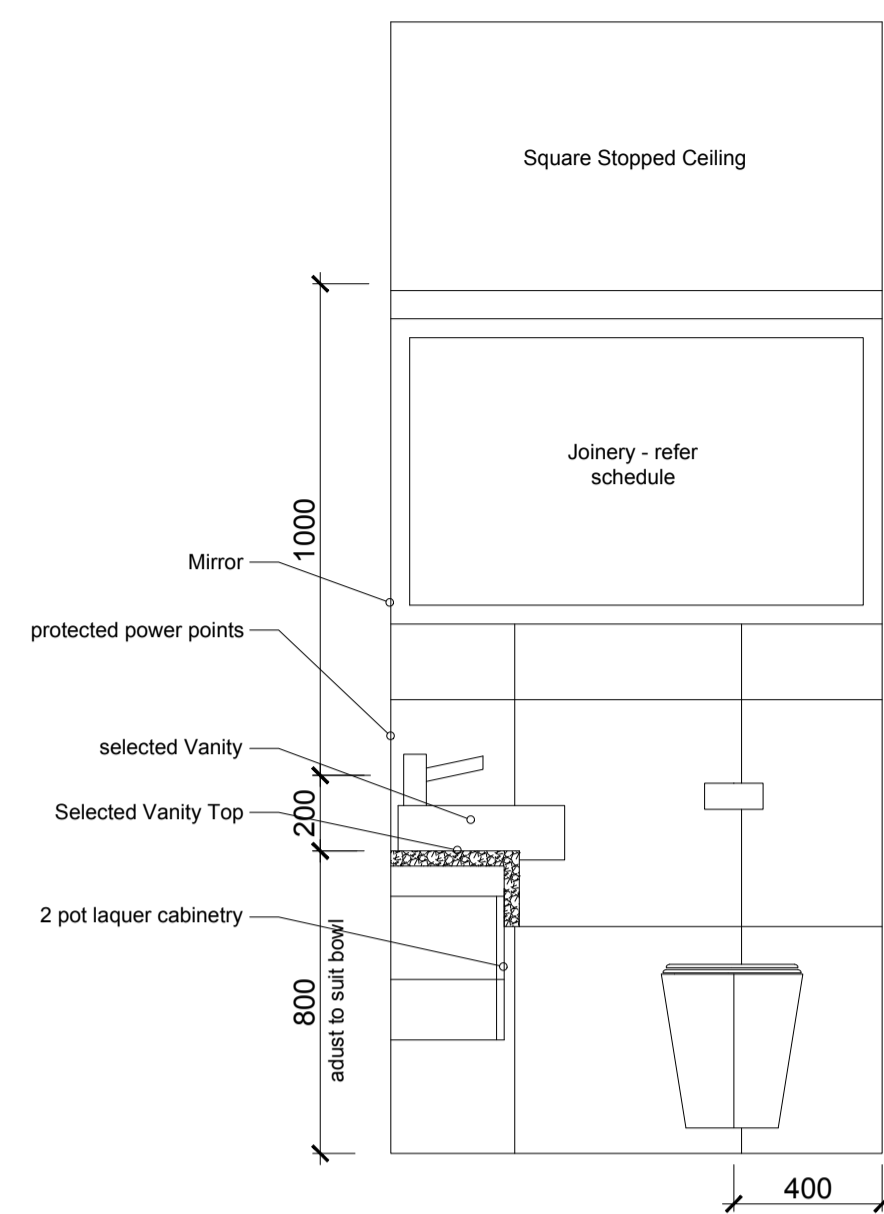

**Shower Room 3 Elevation A**  
scale 1:20  
bthrm

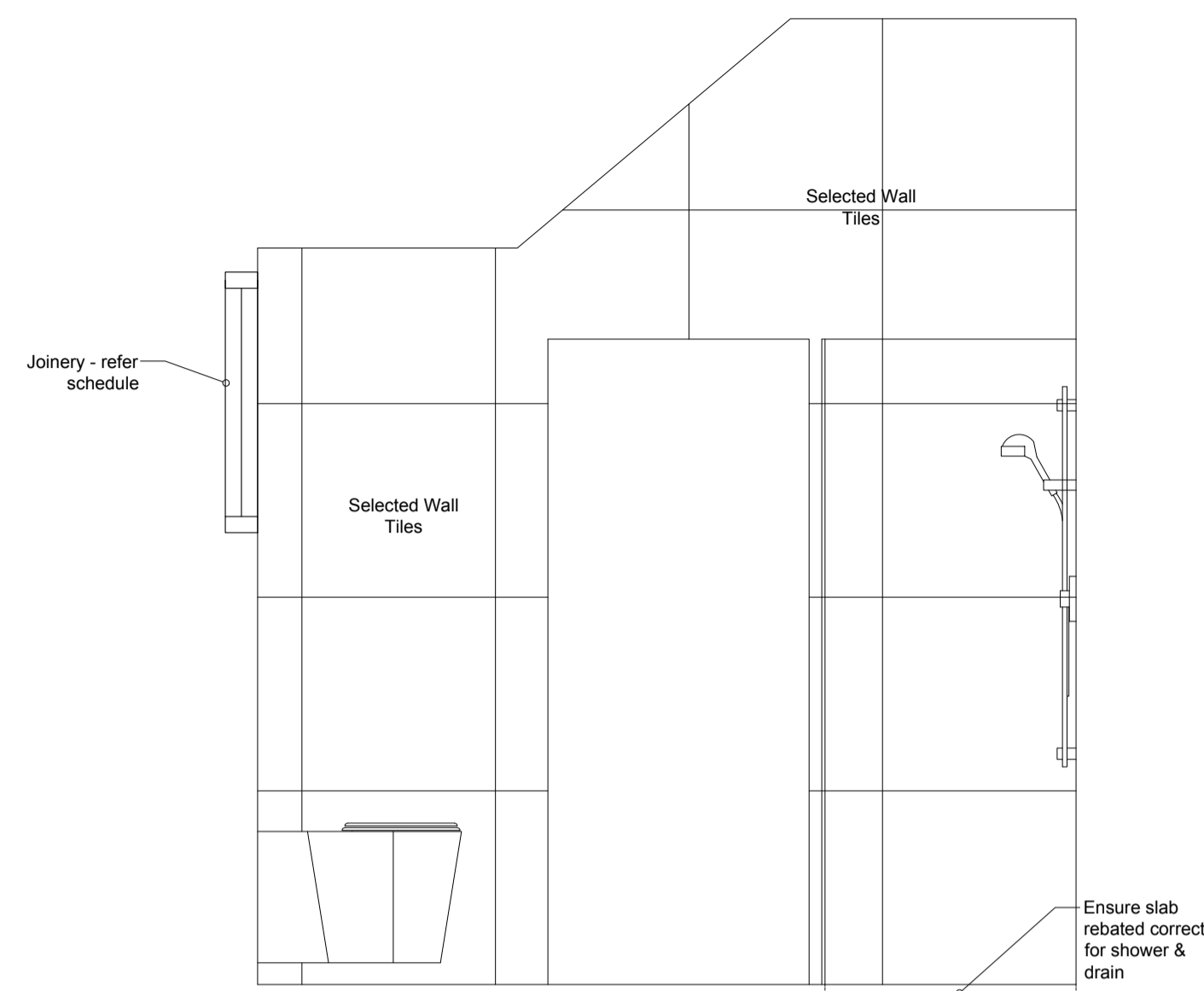

**Shower Room 3 Elevation B**  
scale 1:20  
bthrm

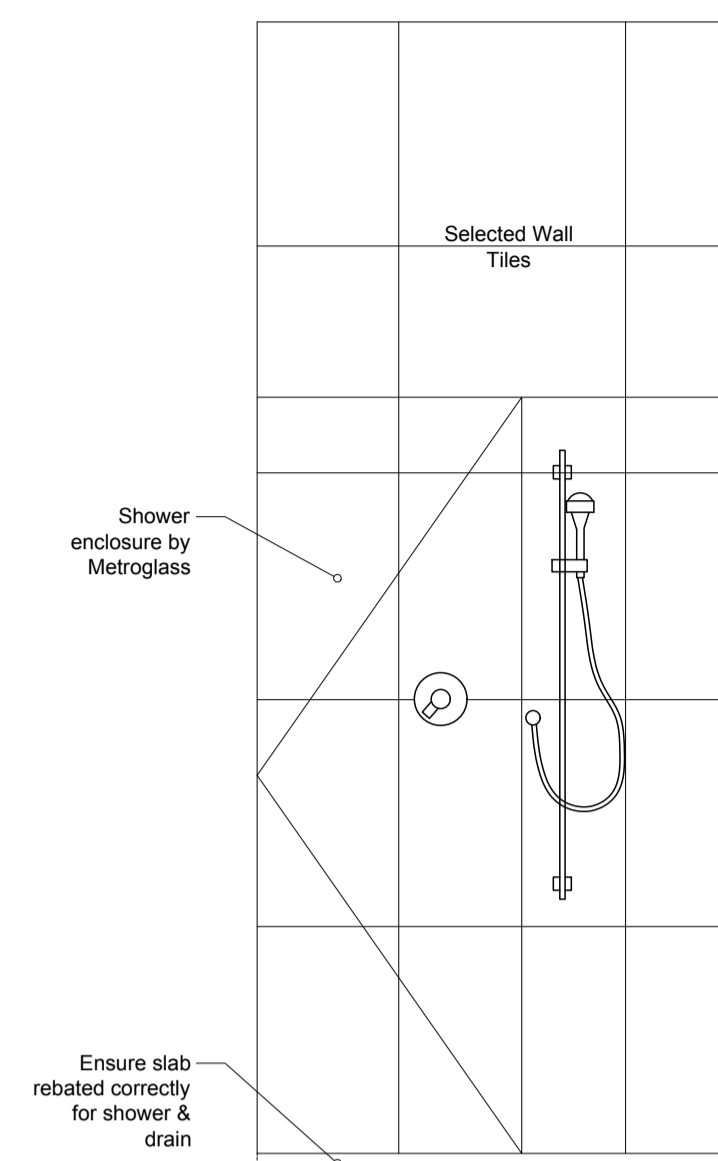

**Shower Room 3 Elevation C**  
scale 1:20  
bthrm

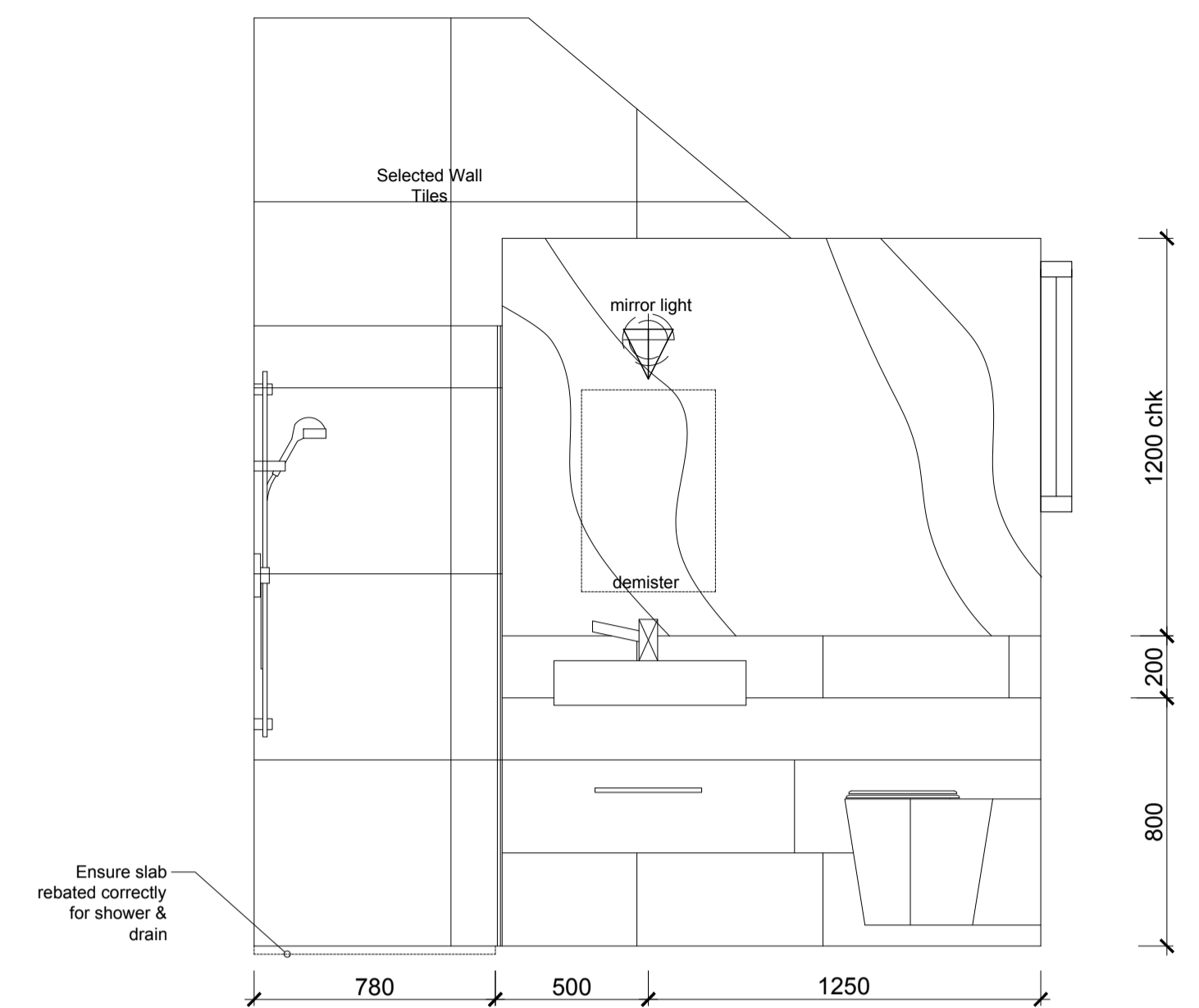

**Shower Room 3 Elevation D**  
scale 1:20  
bthrm

1. All wall tiling on 7.5mm Harditile underlay
2. All cabinet interiors double sided melteca, all edges clashed
3. Confirm all applicable dimensions before manufacture commences.
4. Waterproof all floor, shower, bath, vanity surrounds with ASA Dampfix waterproofing system
5. Allow for coloured grouting to match selected tiling. Colour matched silicone to all angles & butts with adjacent finishes
6. Doors and all exposed cabinetry American Oak all satin laquer finish.

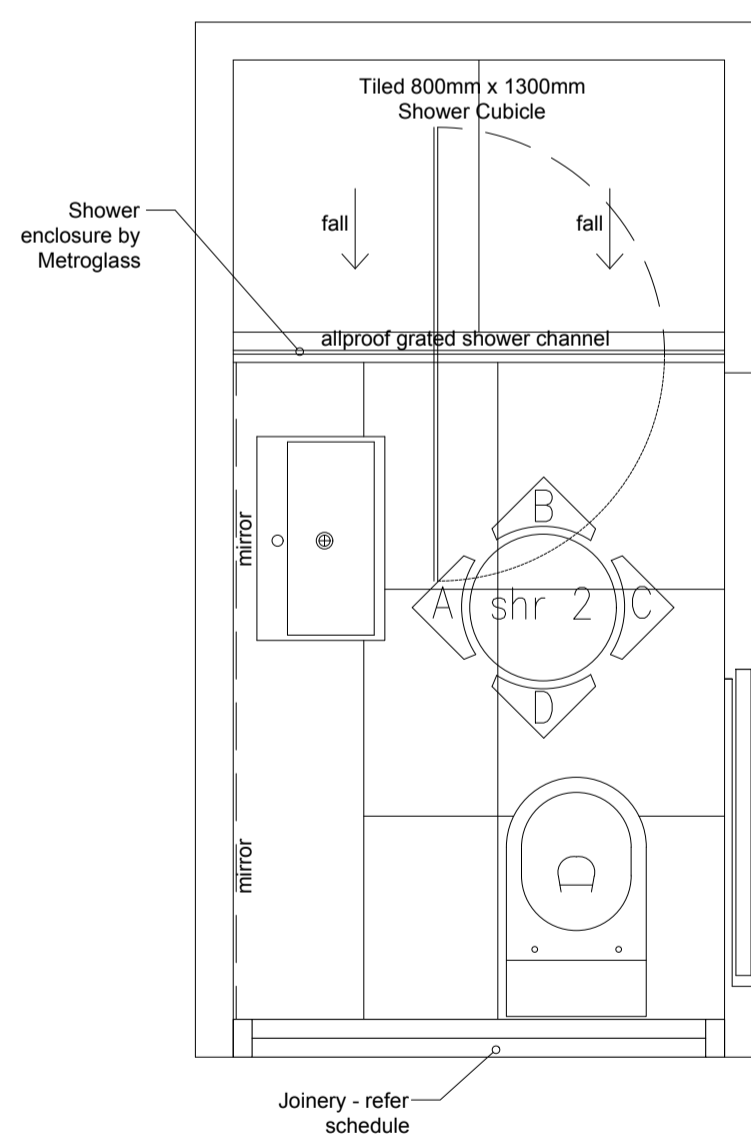

**Shower Room 2**  
scale 1:20  
bthrm

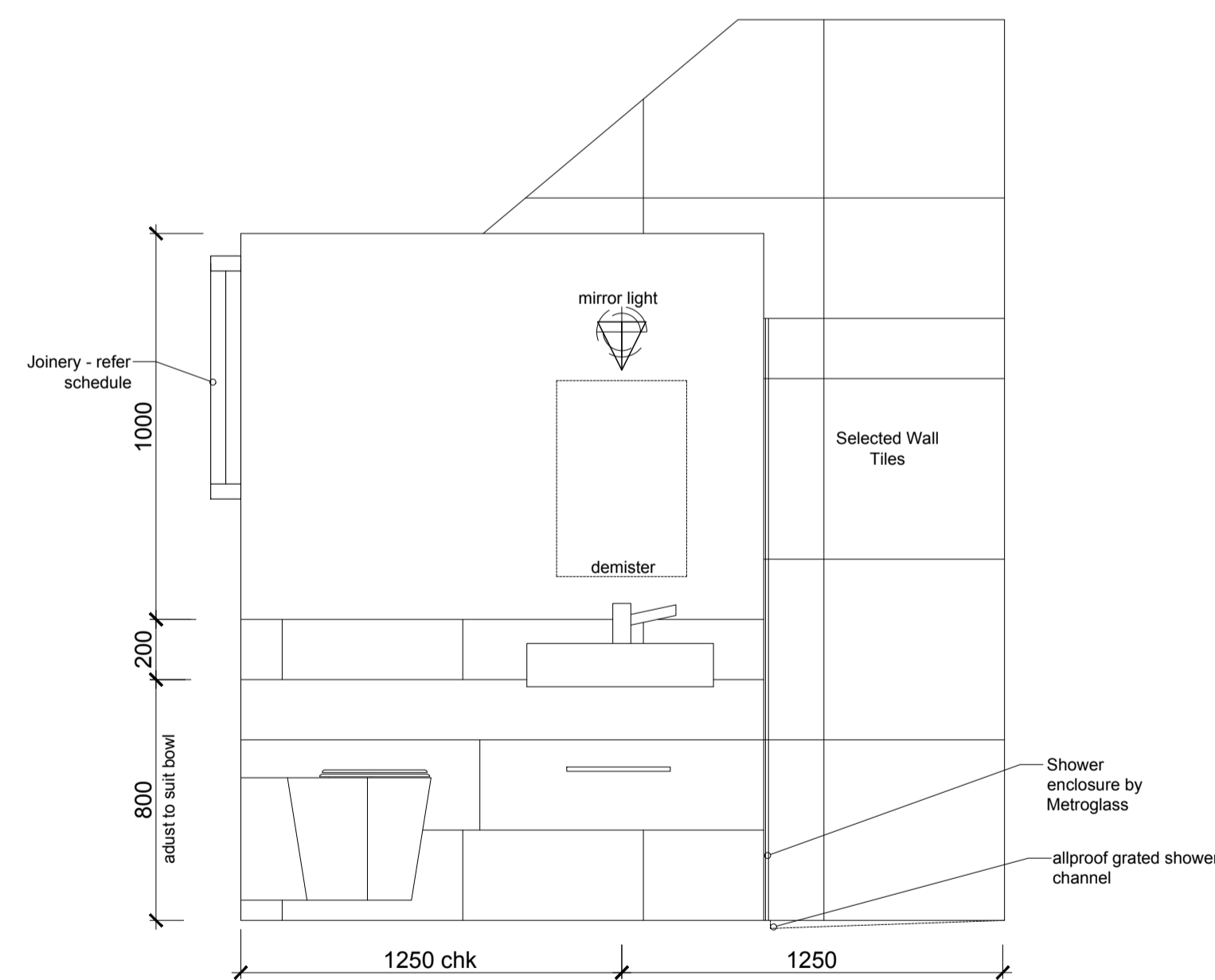

**Shower Room 3 Elevation A**  
scale 1:20  
bthrm

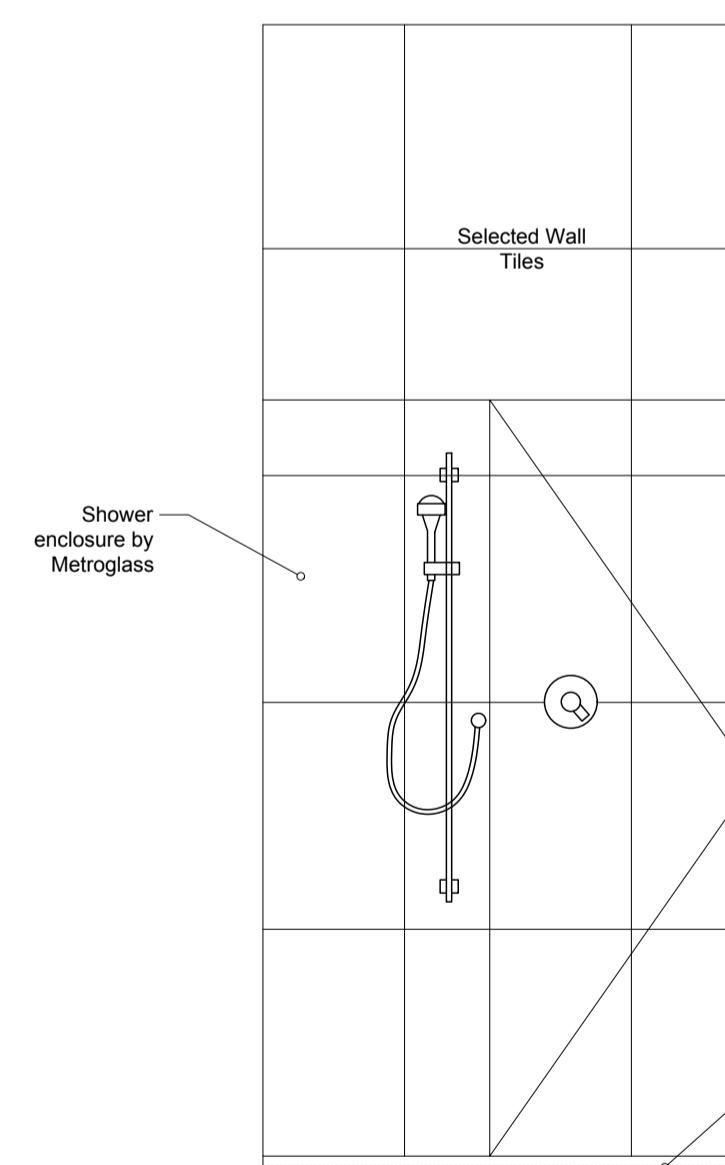

**Shower Room 3 Elevation B**  
scale 1:20  
bthrm

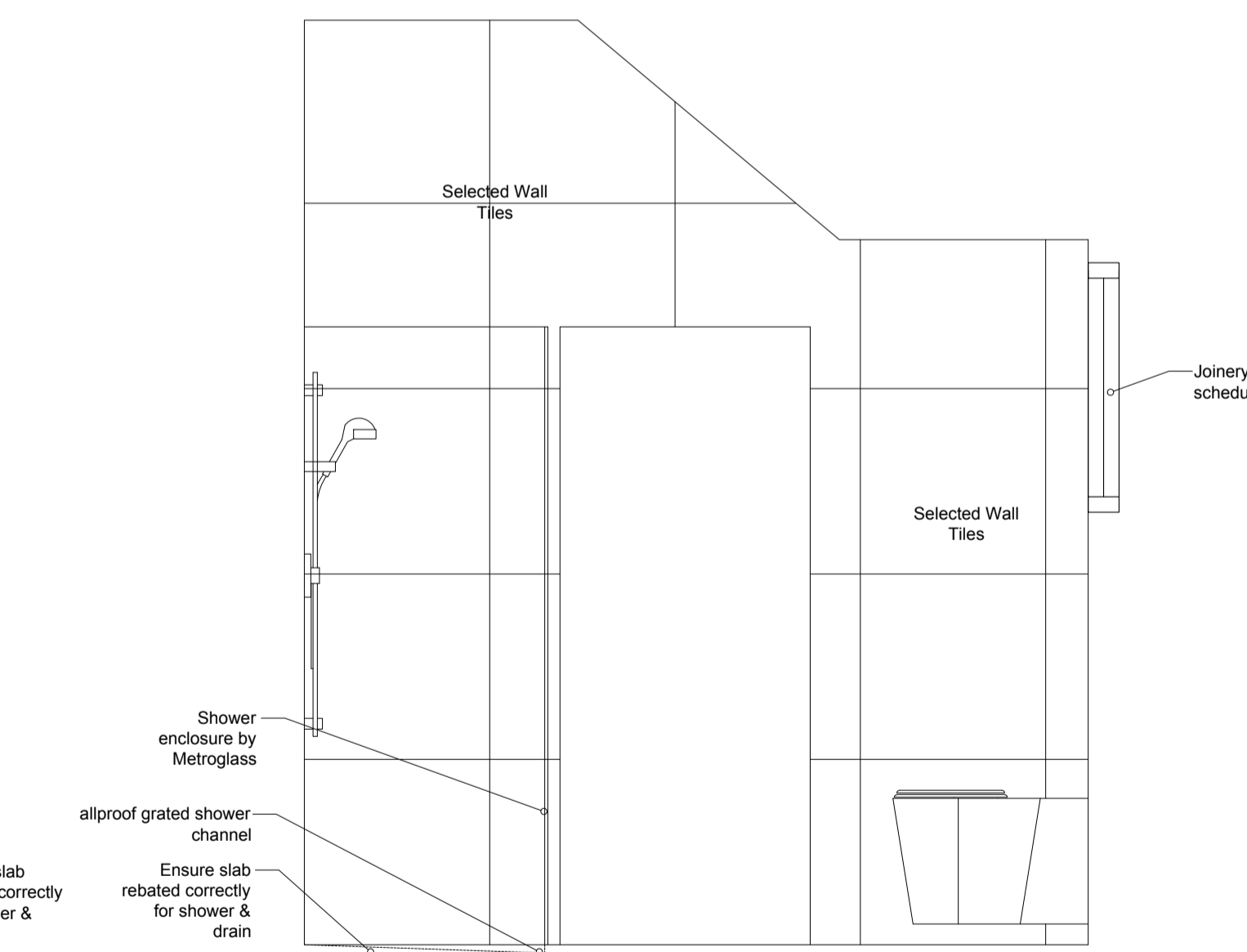

**Shower Room 3 Elevation C**  
scale 1:20  
bthrm

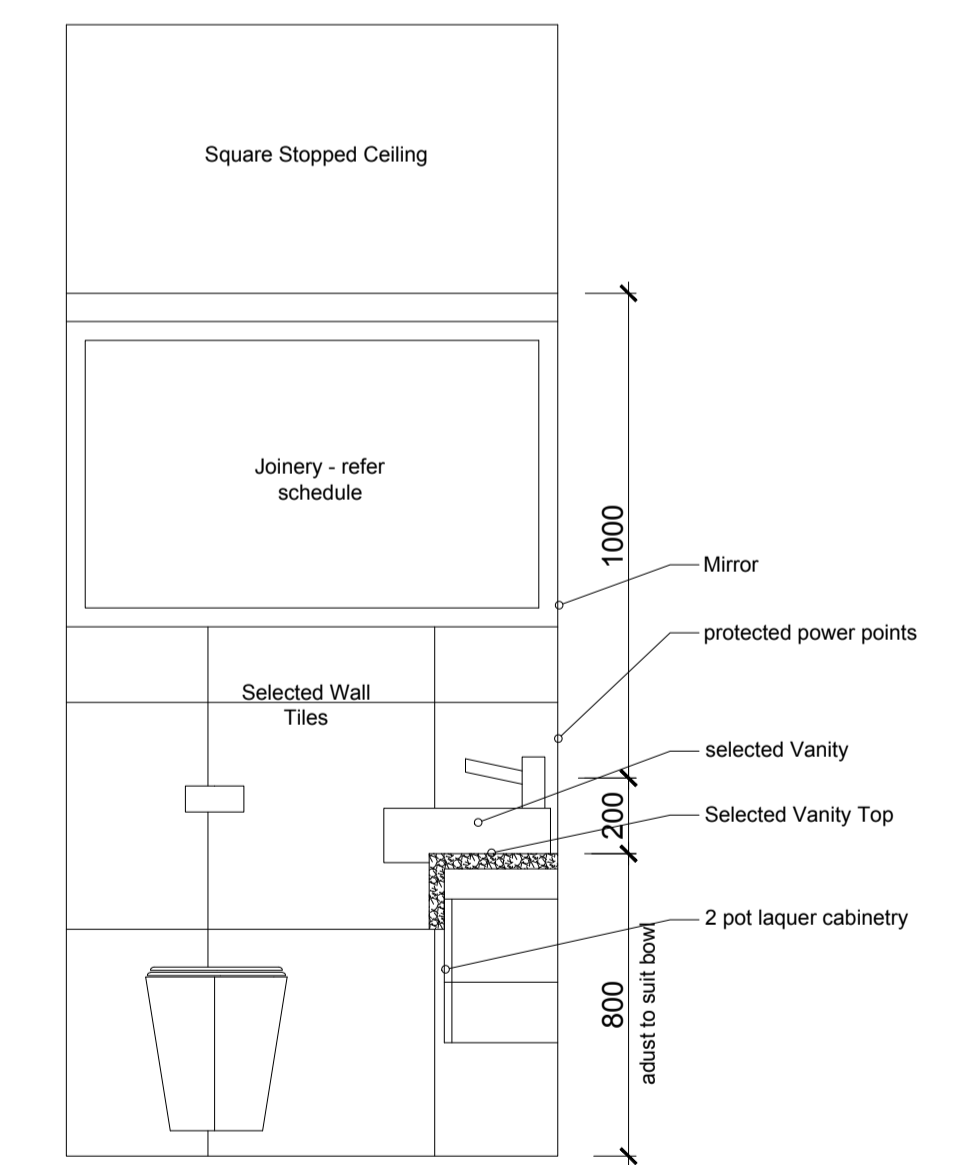

**Shower Room 3 Elevation D**  
scale 1:20  
bthrm

Revisions	General notes

NOTE:

**STAGE 2  
CONSENT**

59 ROSEBERRY AVE BIRKENHEAD AUCKLAND TEL (09)418 2432 FAX (09)419 5142

APARTMENT DEVELOPMENT  
81 SANSFIELD STREET, HERNE BAY

APARTMENT 1  
BATHROOMS

Drawing Reference  
job no: SAR  
dep no: 036

Date: DEC'17  
Scale: 1/20 @ A1  
revision: SAR  
CADREF

**DELAMARE  
ARCHITECTS**

USE FIGURED DIMENSIONS. DO NOT SCALE FROM DRAWING.  
ALL LEVELS AND DIMENSIONS TO BE CHECKED ON SITE.  
DRAWING TO BE READ IN CONJUNCTION WITH ALL  
RELEVANT DOCUMENTS.  
© THE CONTENT OF THIS DRAWING IS THE PROPERTY  
OF DAVID DELAMARE

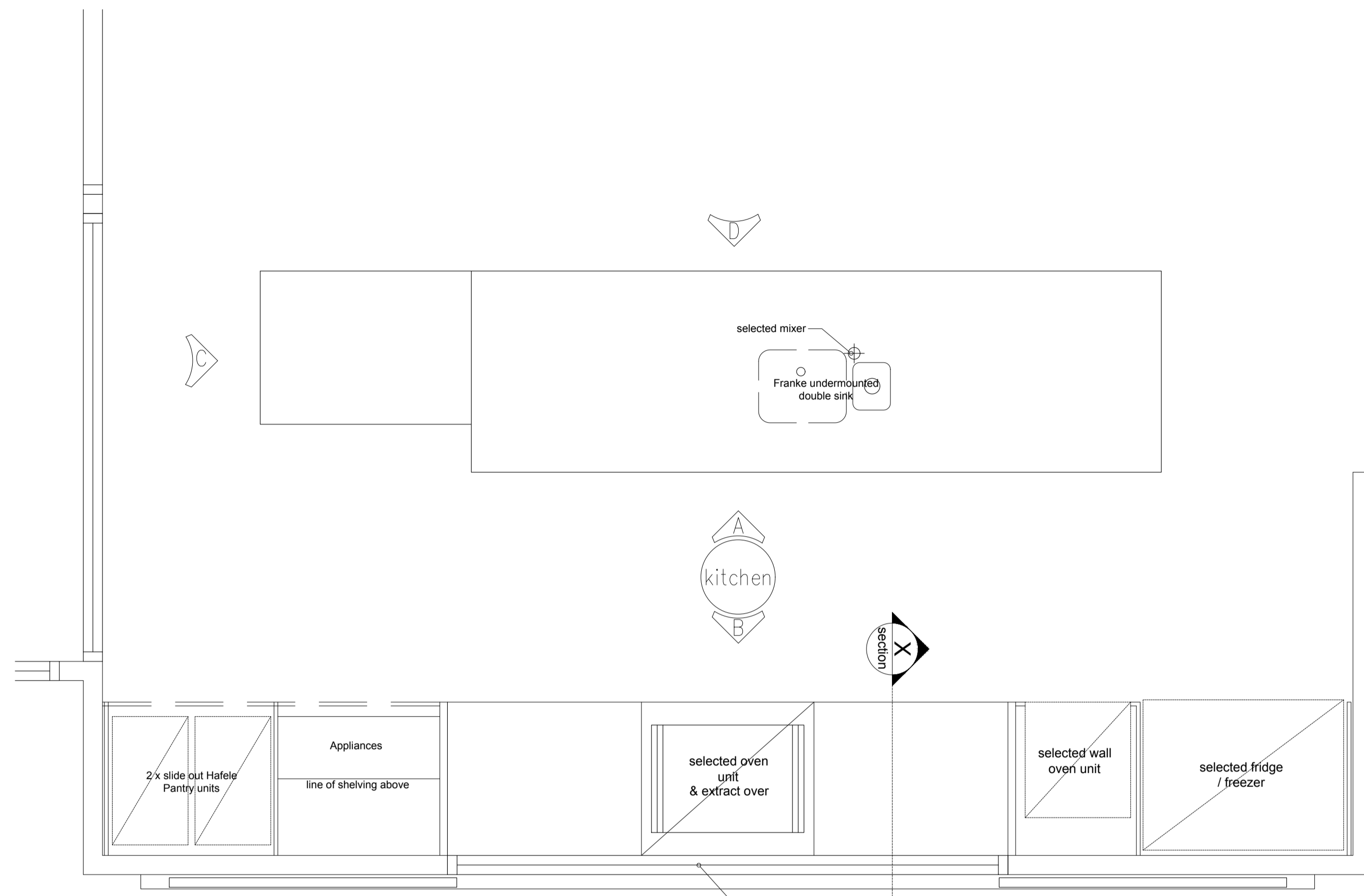

**Kitchen - Apartment 1**  
scale 1:20

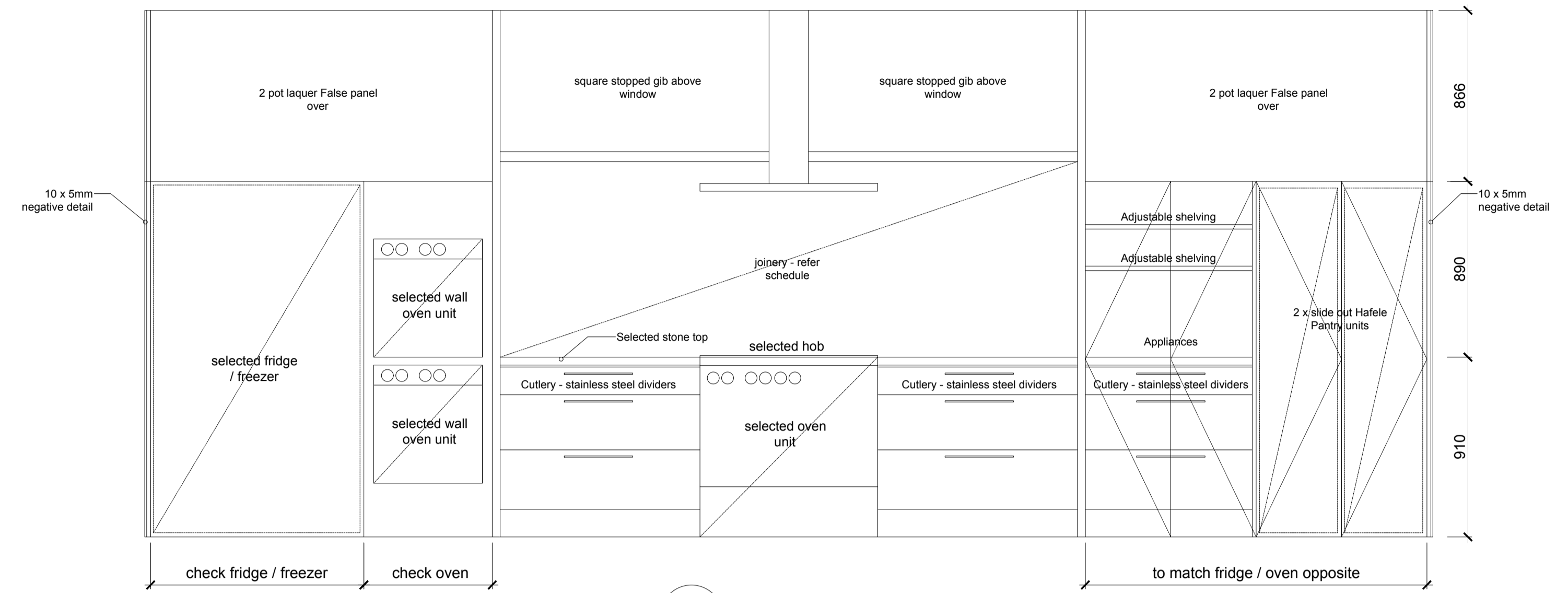

**B Kitchen Elevation**  
scale 1:20

1. Exterior cabinets all satin laquer
2. All interiors double sided melteca or as noted
3. Confirm all appliance dimensions before manufacture commences.
4. Owner to provide installation instructions of all selected appliances.
5. Fit stainless steel cutlery dividers to cutlery drawers.
6. Selected granite tops in nett sum.
7. Handles included in hardware sum
8. All shelves adustable.
9. All hinges and drawer runners by Blum or Grasse
10. All electrical switches and isolating switches are to be installed in Pantry / Fridge enclosure walls - Not in Backpainted glass
11. Overmounted cupboards & drawers throughout
12. Stainless Steel cutlery divisions & pantry units by Hafele
13. Allow to install existing wastemaster, new dishwasher, induction hob & electric oven

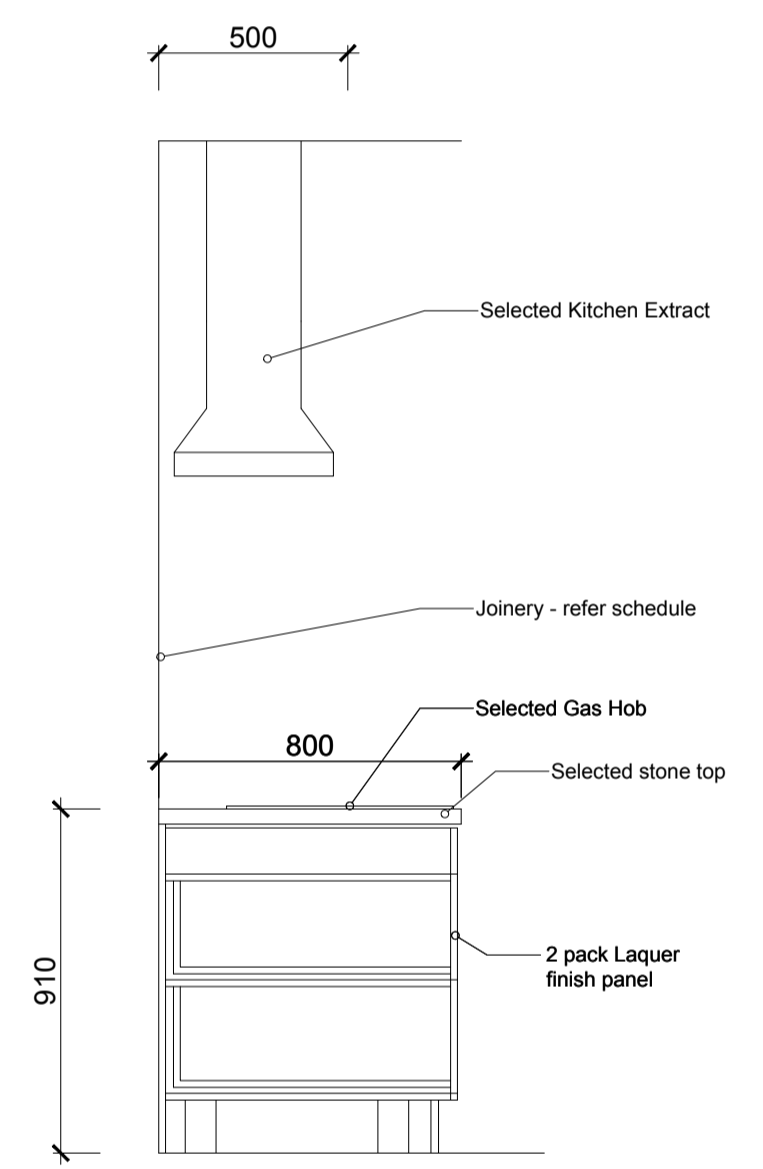

**X Kitchen Section**  
scale 1:20

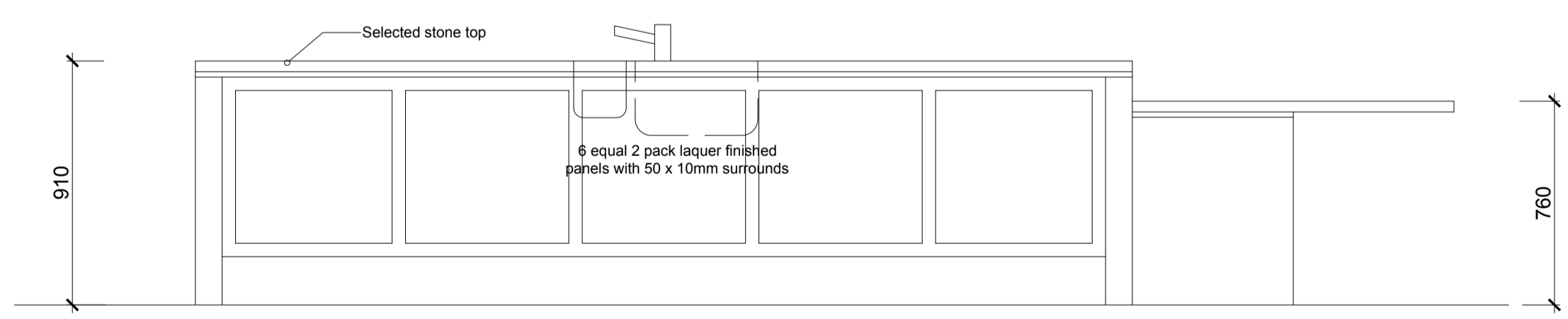

**D Kitchen Elevation**  
scale 1:20

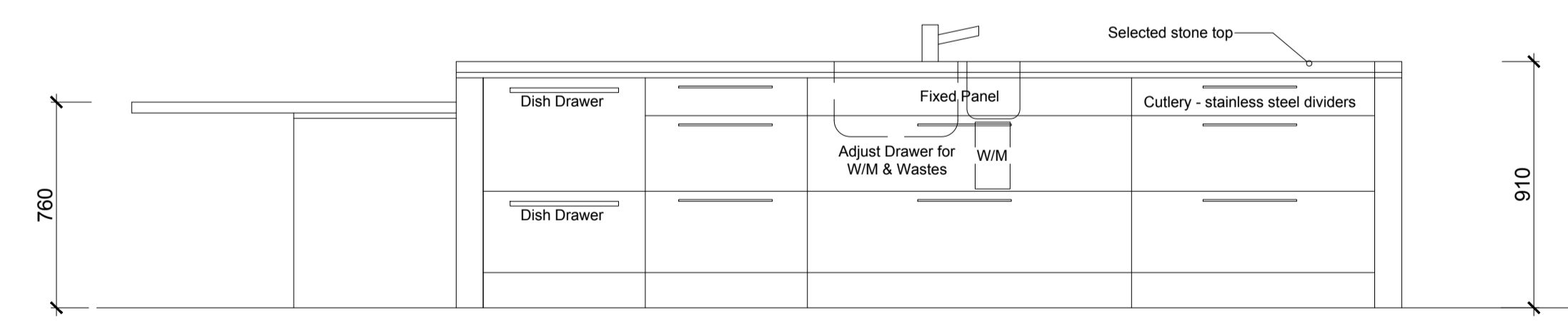

**B Kitchen Elevation**  
scale 1:20

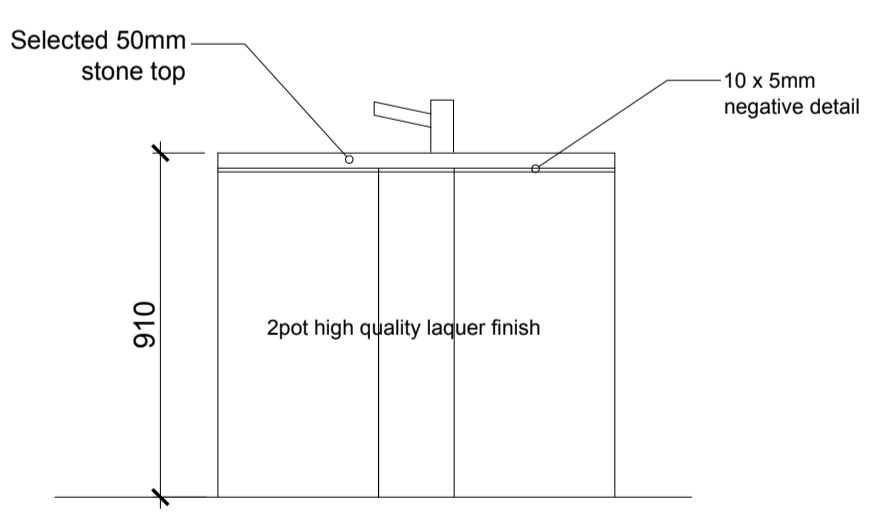

**C Kitchen Elevation**  
scale 1:20

Revisions	General notes

NOTE:  
**STAGE 2  
CONSENT**

59 ROSEBERRY AVE BIRKENHEAD AUCKLAND TEL (09)418 2432 FAX (09)419 5142  
 APARTMENT DEVELOPMENT  
 81 SARSFIELD STREET, HERNE BAY

**DELAMARE ARCHITECTS**

APARTMENT 1 KITCHEN  
 Drawing Reference: SAR 037  
 Date: DEC'17  
 Scale: 1/20 @ A1  
 Job no: SAR  
 Des no: 037  
 Revision: SAR  
 Cod ref: SAR  
 CADREF

USE FOURED DIMENSIONS. DO NOT SCALE FROM DRAWING. ALL LEVELS AND DIMENSIONS TO BE CHECKED ON SITE. DRAWING TO BE READ IN CONJUNCTION WITH ALL RELEVANT DOCUMENTS. ©THE COPYRIGHT OF THIS DRAWING IS THE PROPERTY OF DAVID DELAMARE.

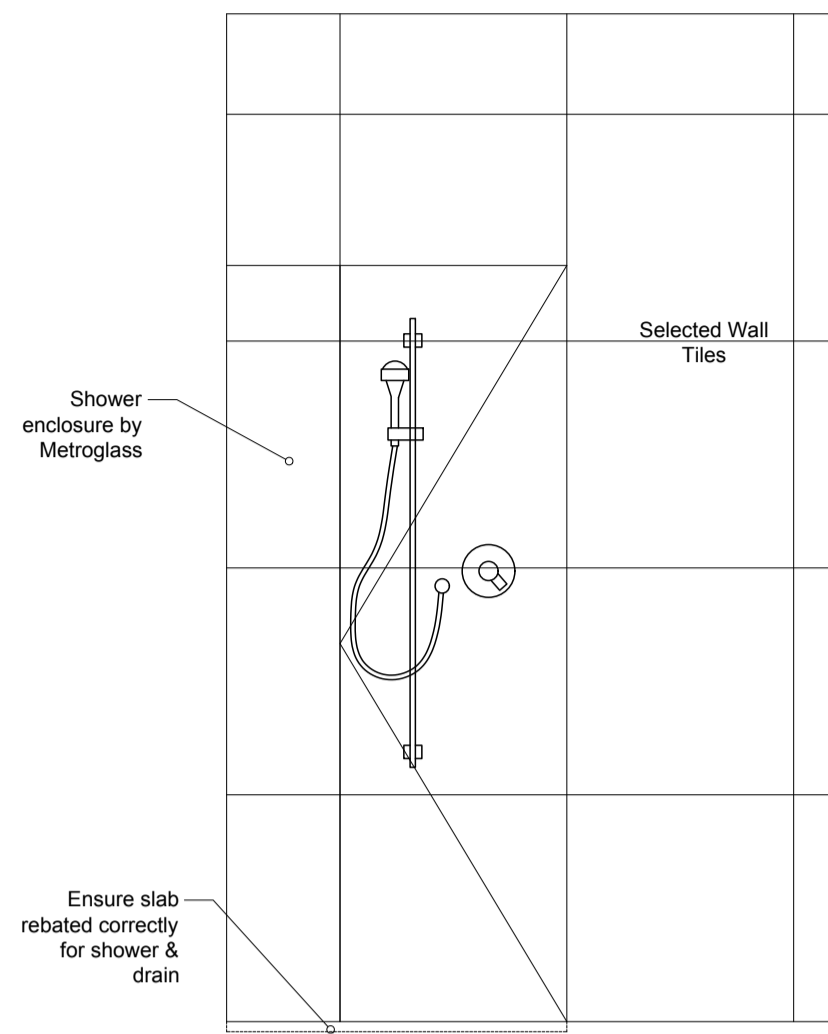

**Ensuite 2 Elevation D**  
bthrm scale 1:20

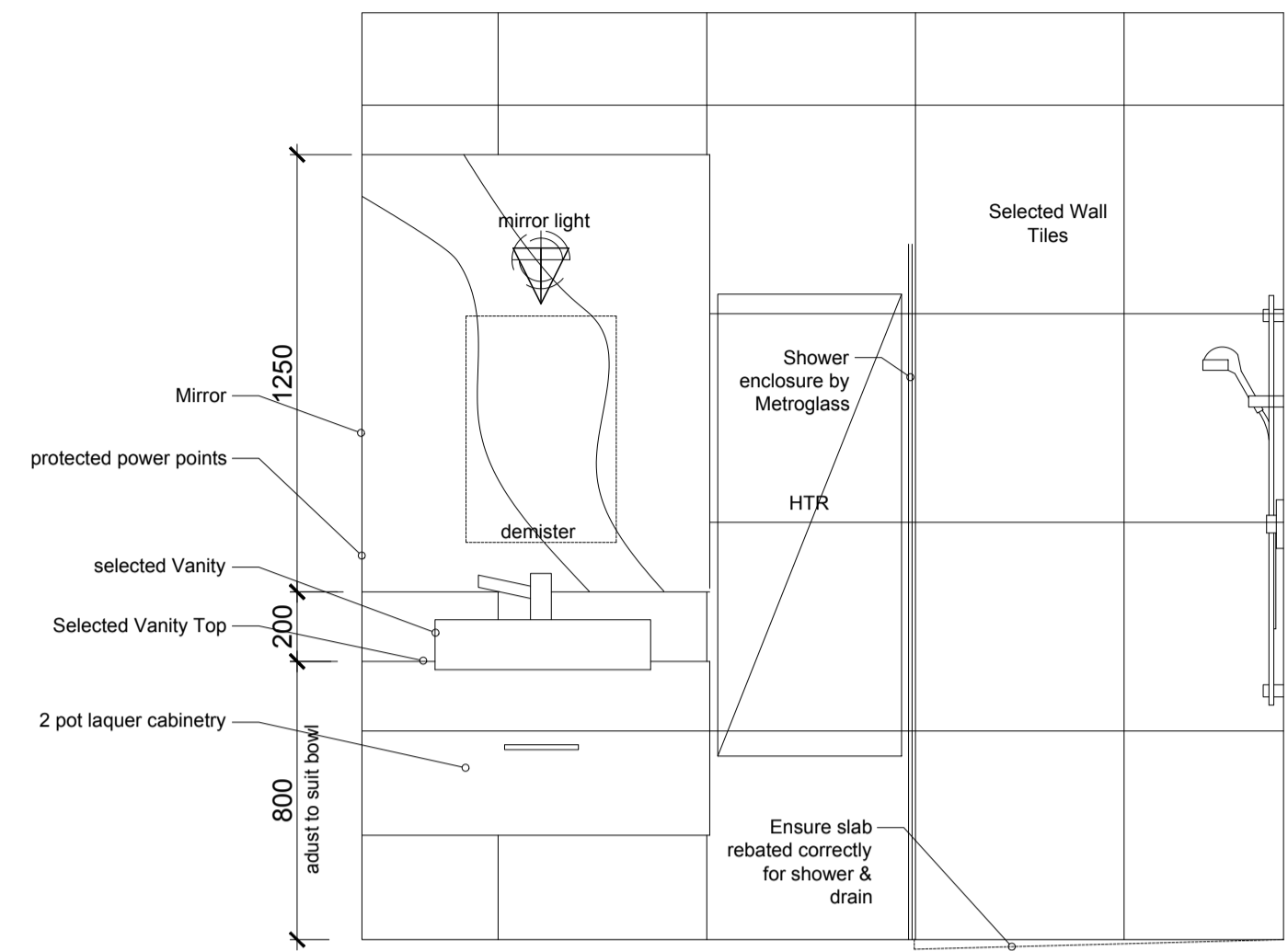

**Ensuite 2 Elevation C**  
bthrm scale 1:20

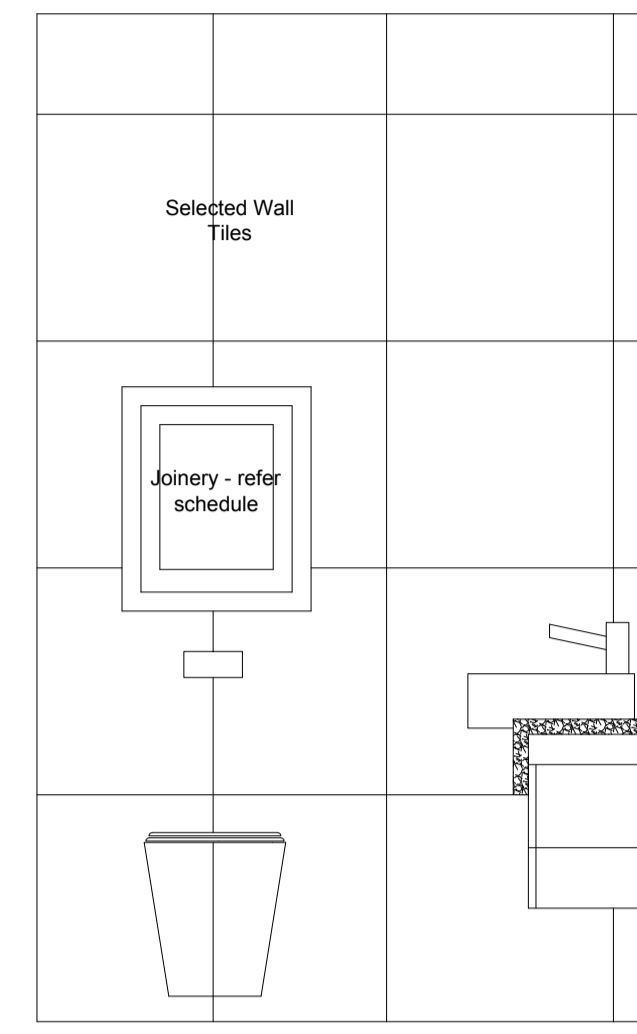

**Ensuite 2 Elevation B**  
bthrm scale 1:20

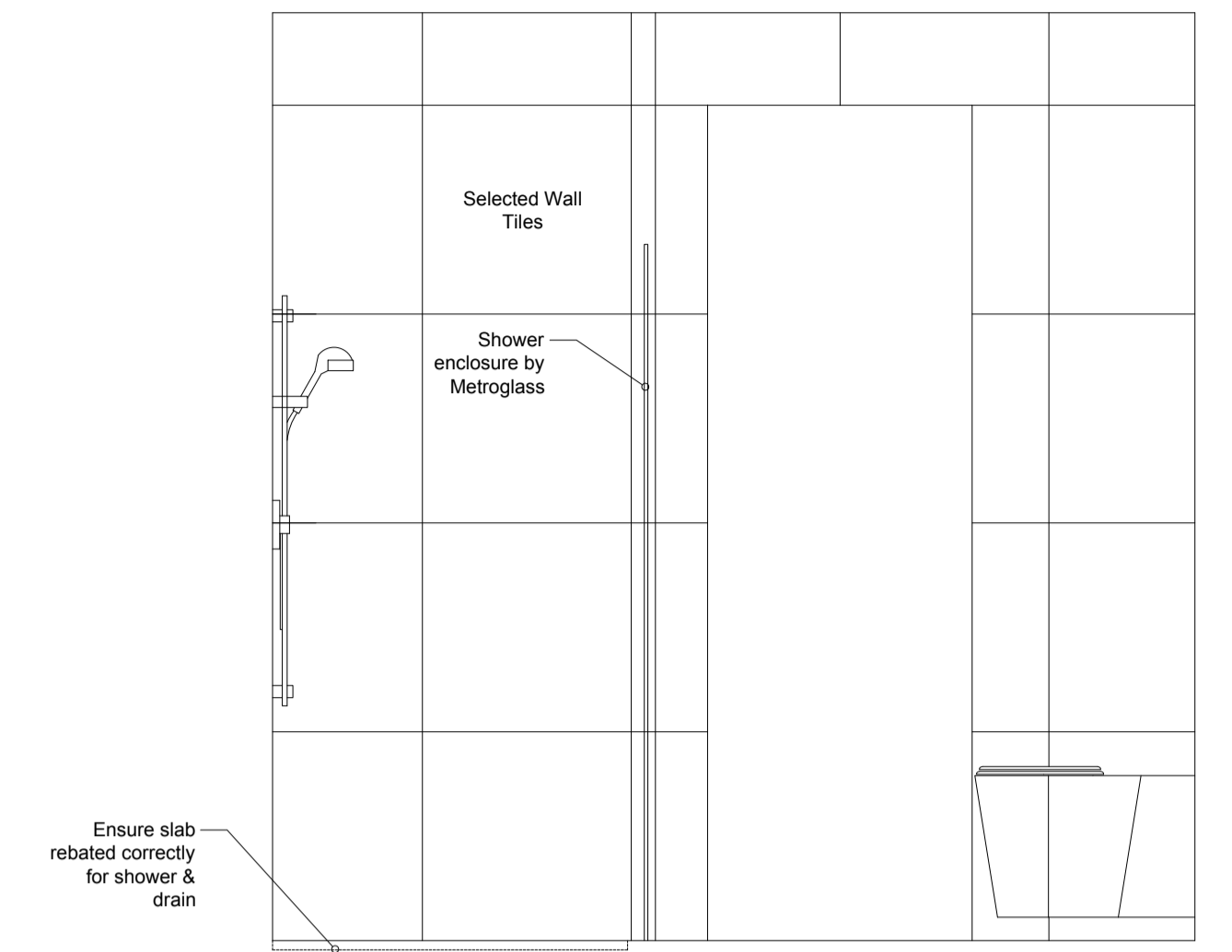

**Ensuite 2 Elevation A**  
bthrm scale 1:20

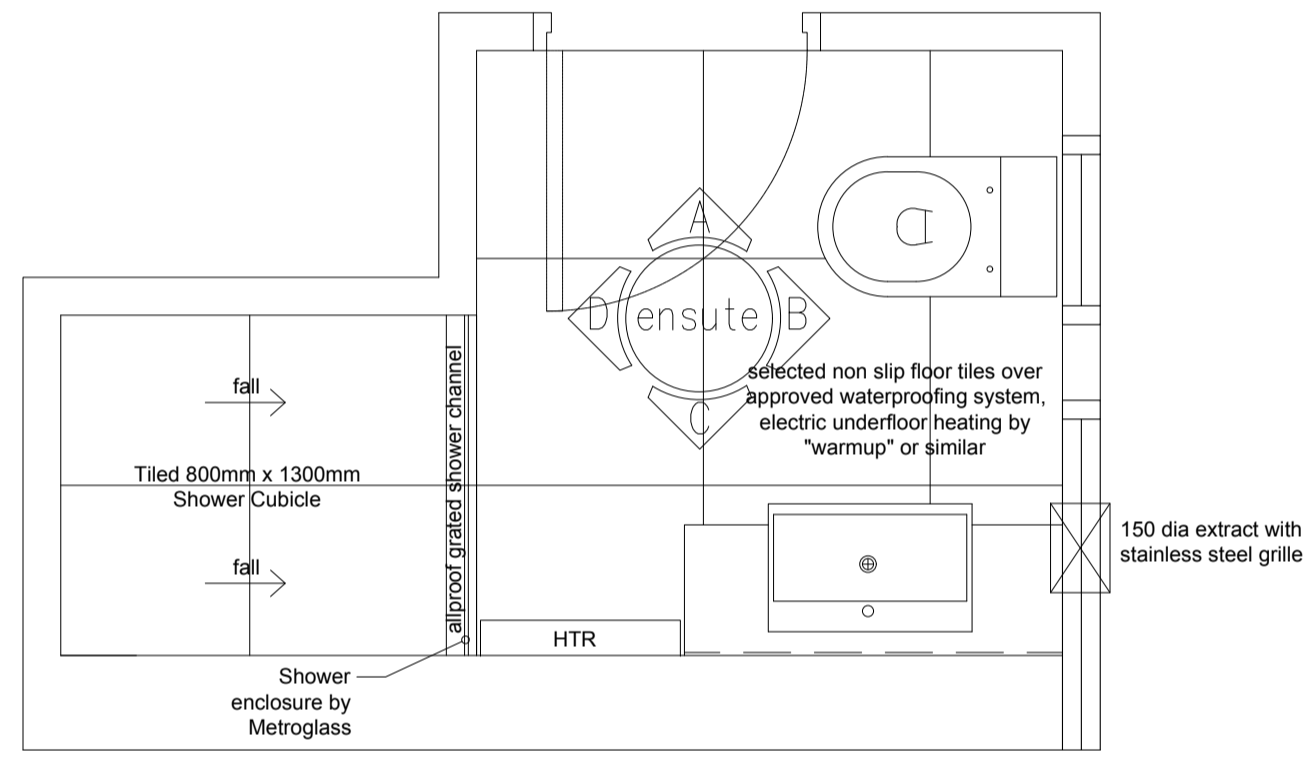

**Ensuite 2**  
bthrm scale 1:20

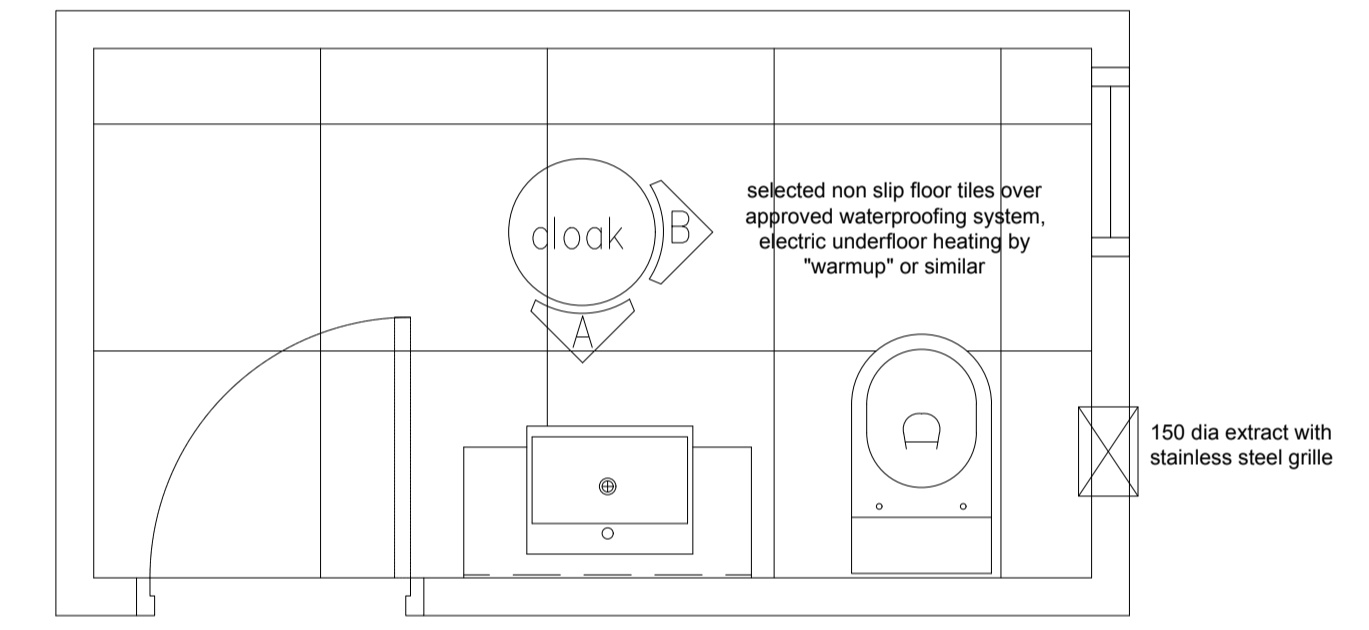

**Cloak**  
bthrm scale 1:20

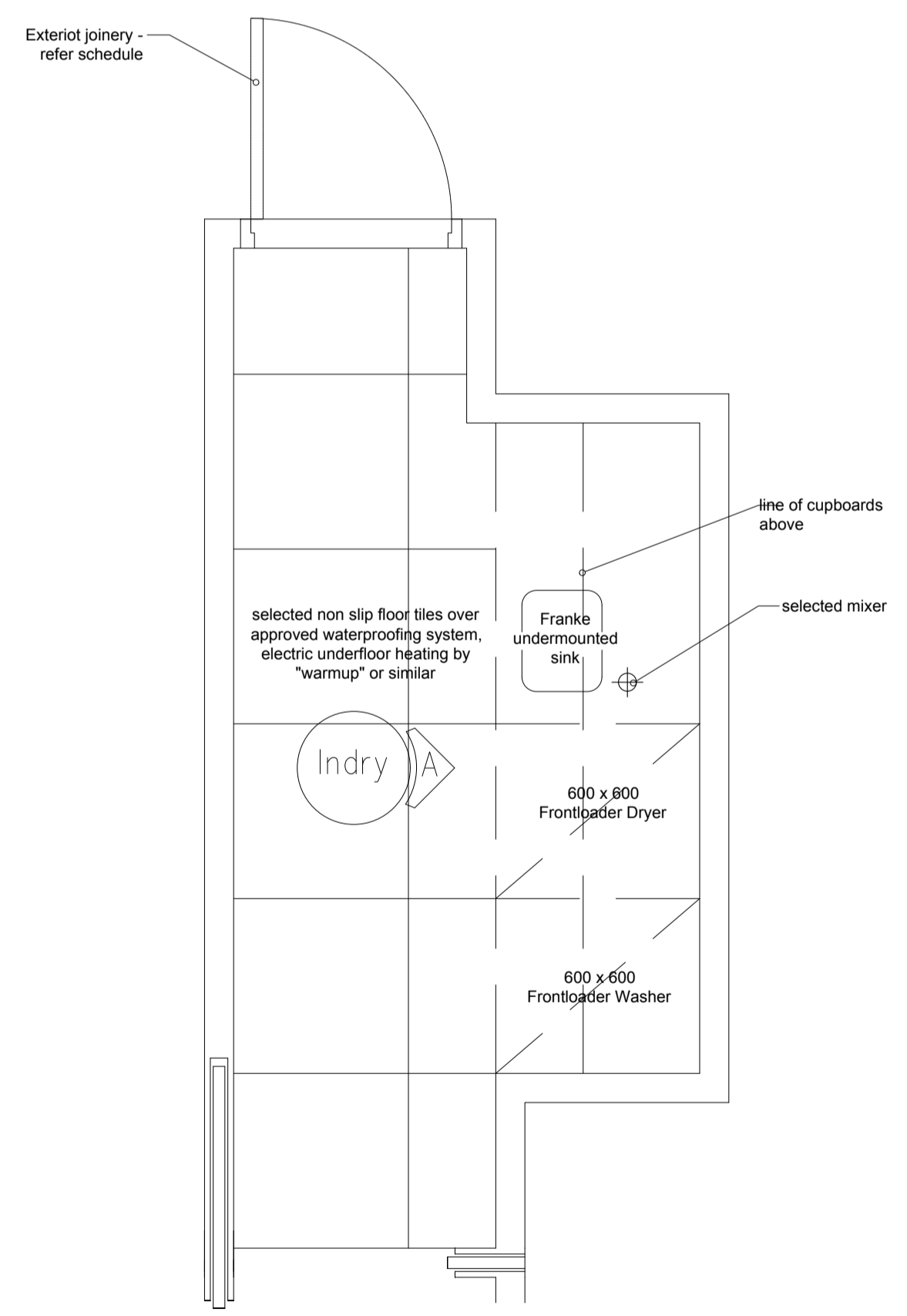

**Laundry**  
bthrm scale 1:20

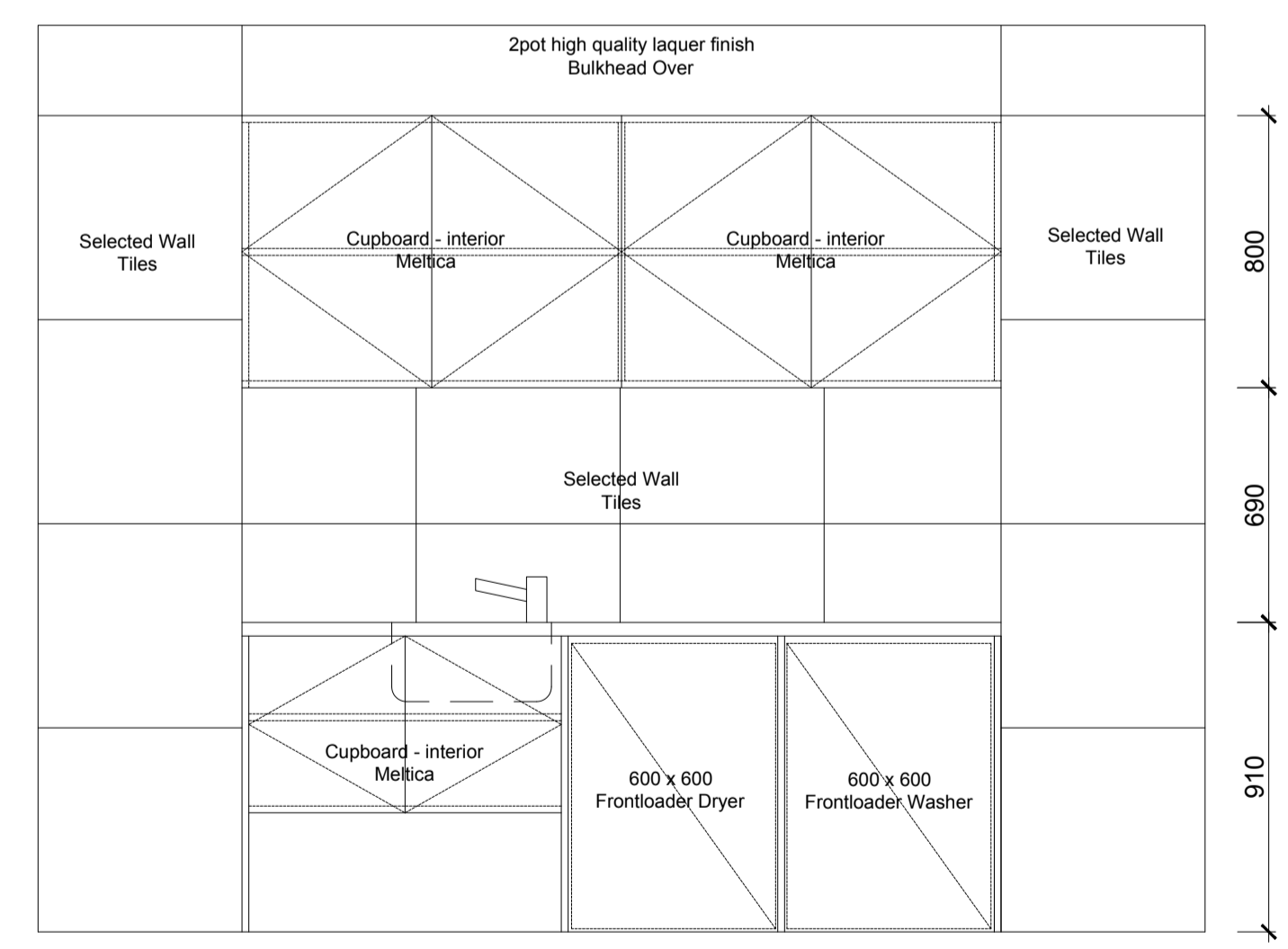

**Laundry Elevation A**  
bthrm scale 1:20

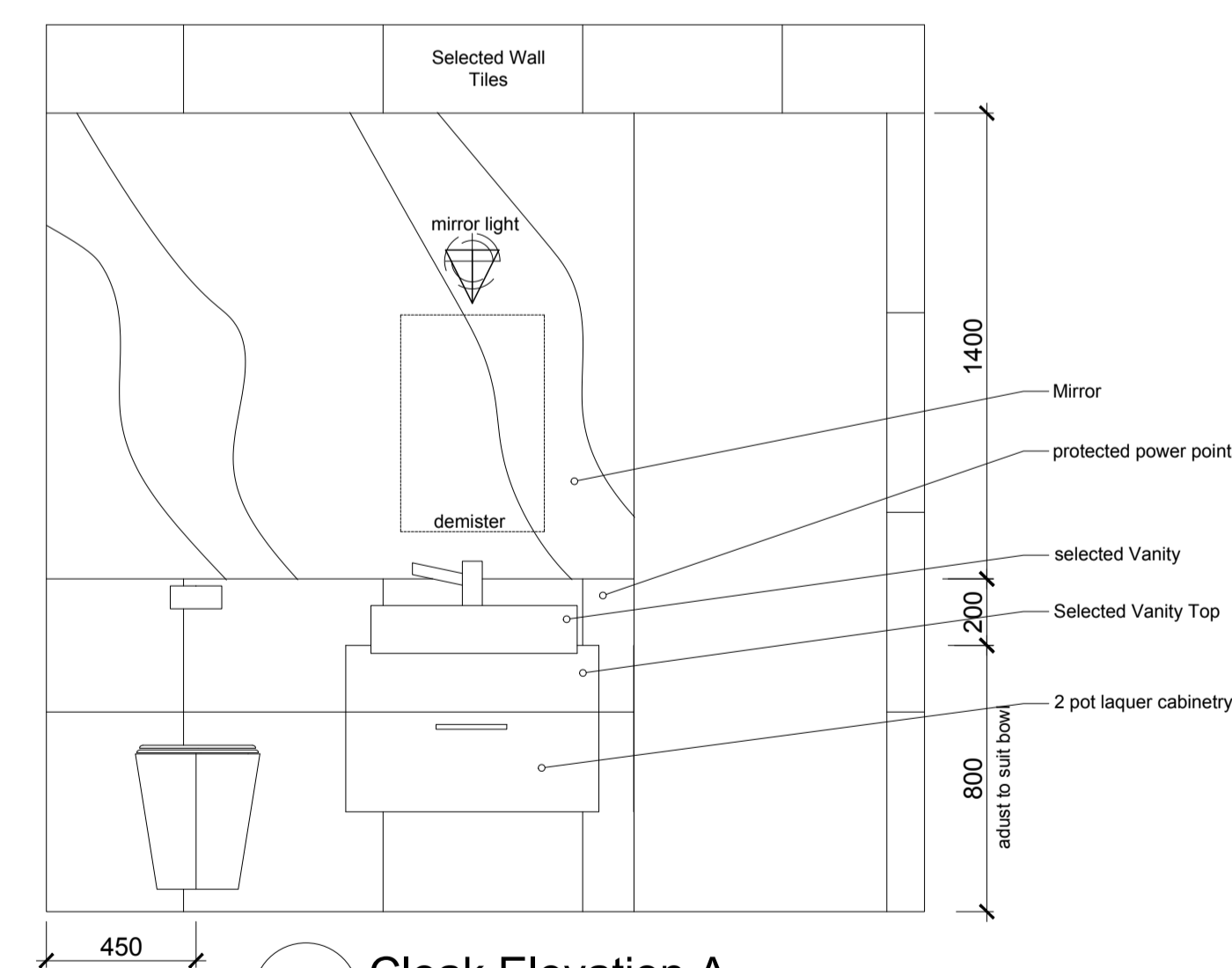

**Cloak Elevation A**  
bthrm scale 1:20

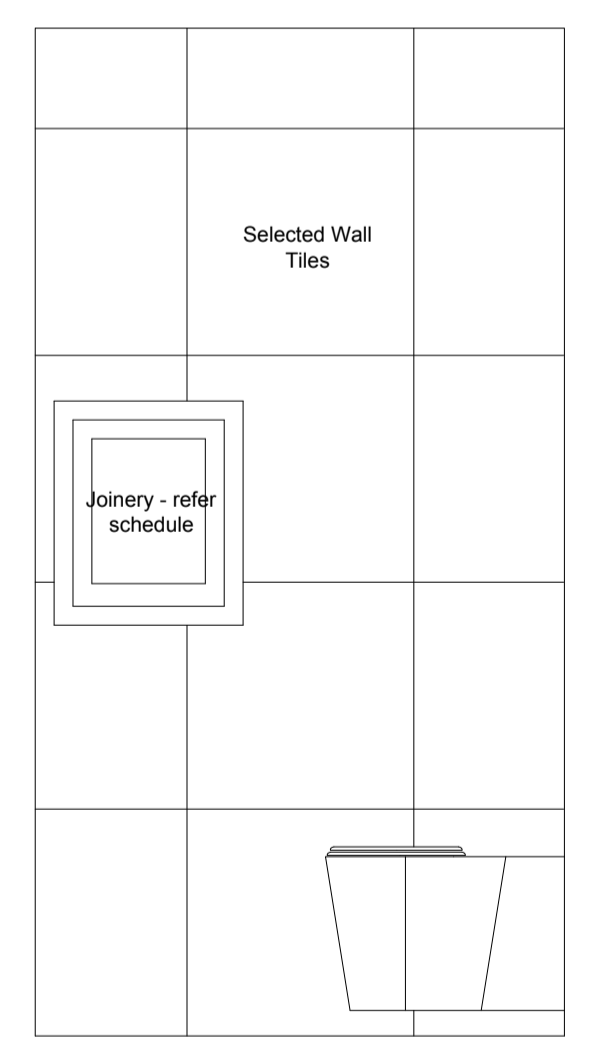

**Cloak Elevation B**  
bthrm scale 1:20

Revisions	General notes

NOTE:  
**STAGE 2  
CONSENT**

59 ROSEBERRY AVE BIRKENHEAD AUCKLAND TEL (09)418 2432 FAX (09)419 5142  
**APARTMENT DEVELOPMENT**  
 81 SARSFIELD STREET, HERNE BAY

Date DEC'17  
 Scale 1/20 @ A1  
 Drawing Reference  
 APARTMENT 1 Job no SAR  
 BATH & LAUNDRY Dep no 038  
 revision  
 Cod ref SAR  
 CADREF

**DELAMARE ARCHITECTS**  
USE DIMENSIONS. DO NOT SCALE FROM DRAWING. ALL LEVELS AND DIMENSIONS TO BE CHECKED ON SITE. DRAWING TO BE READ IN CONJUNCTION WITH ALL RELEVANT DOCUMENTS. ©THE COPYRIGHT OF THIS DRAWING IS THE PROPERTY OF DAVID DELAMARE.

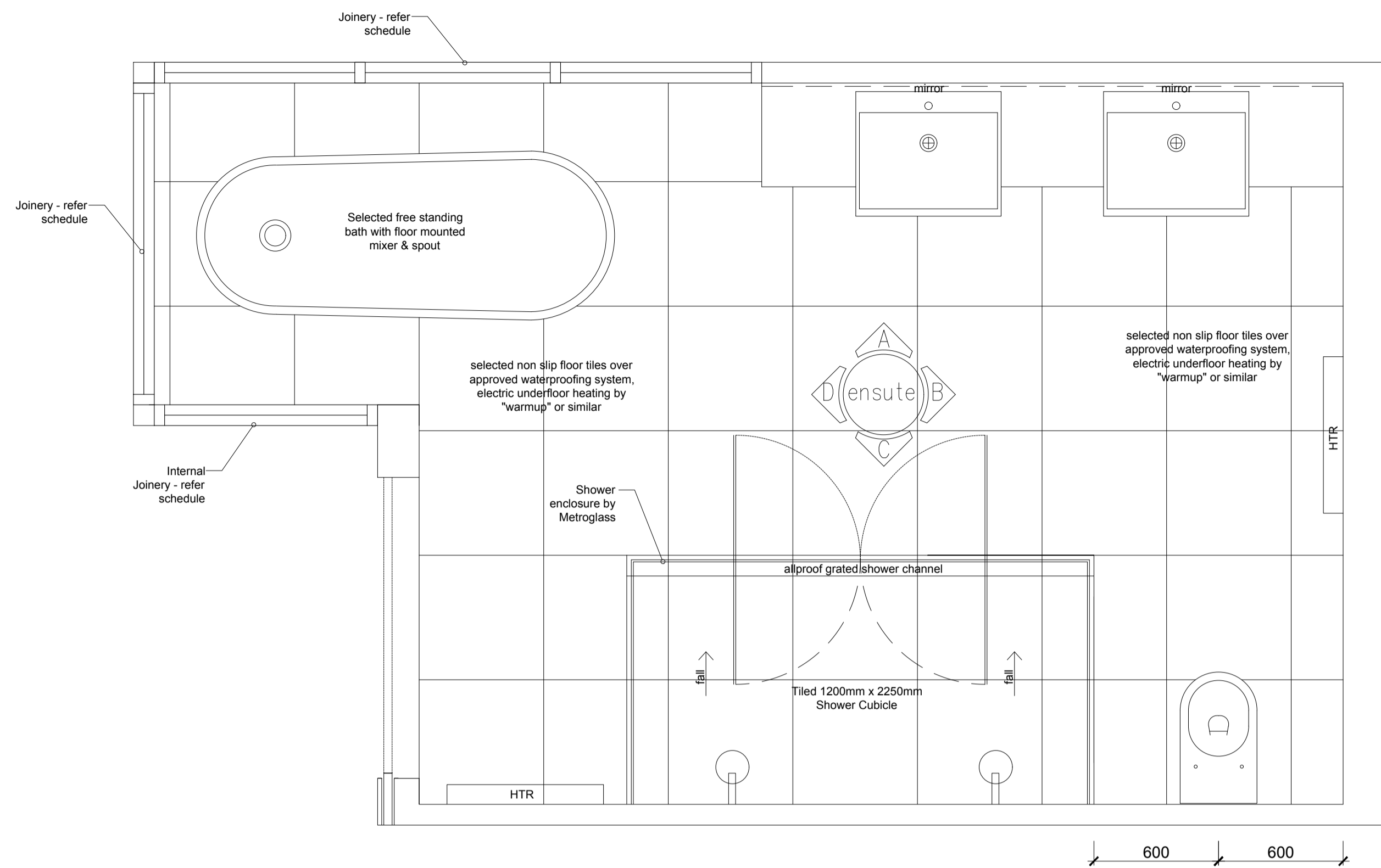

**Master Ensuite - Apartment 2**  
bthrm scale 1:20

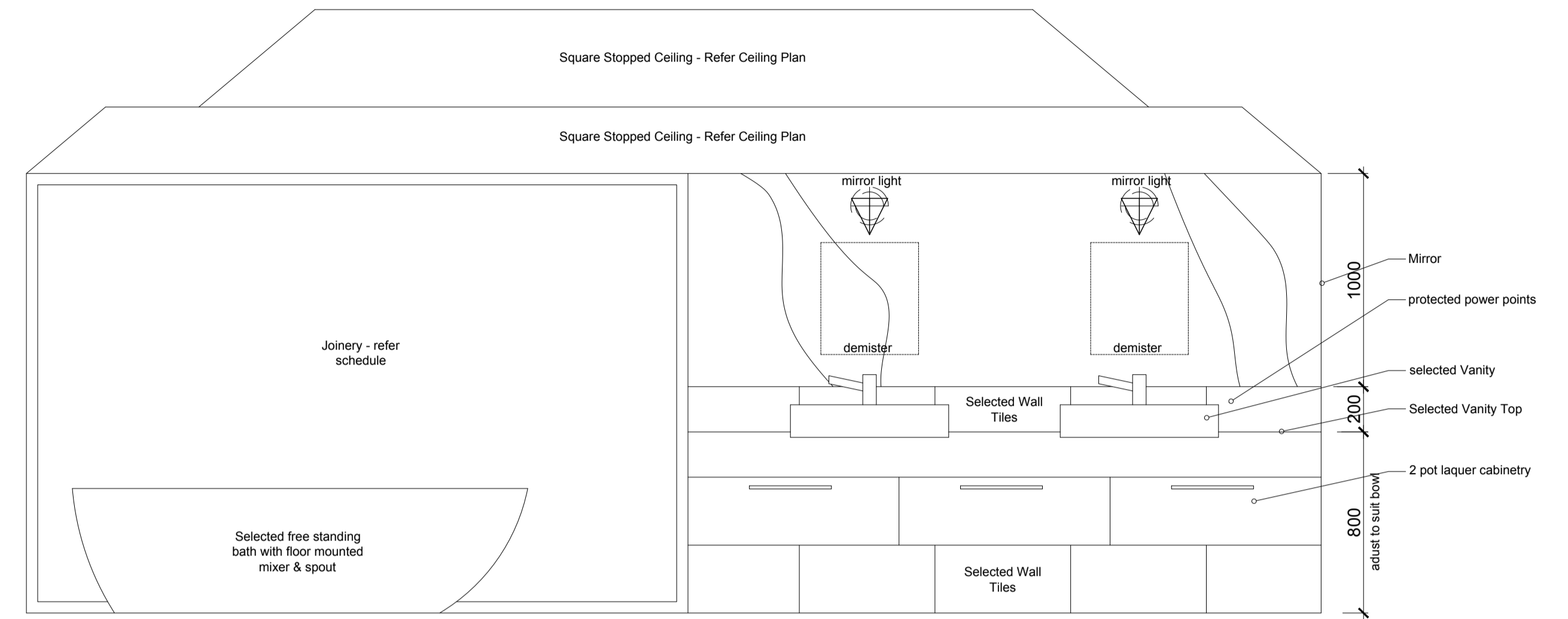

**Master Ensuite - Elevation A**  
bthrm scale 1:20

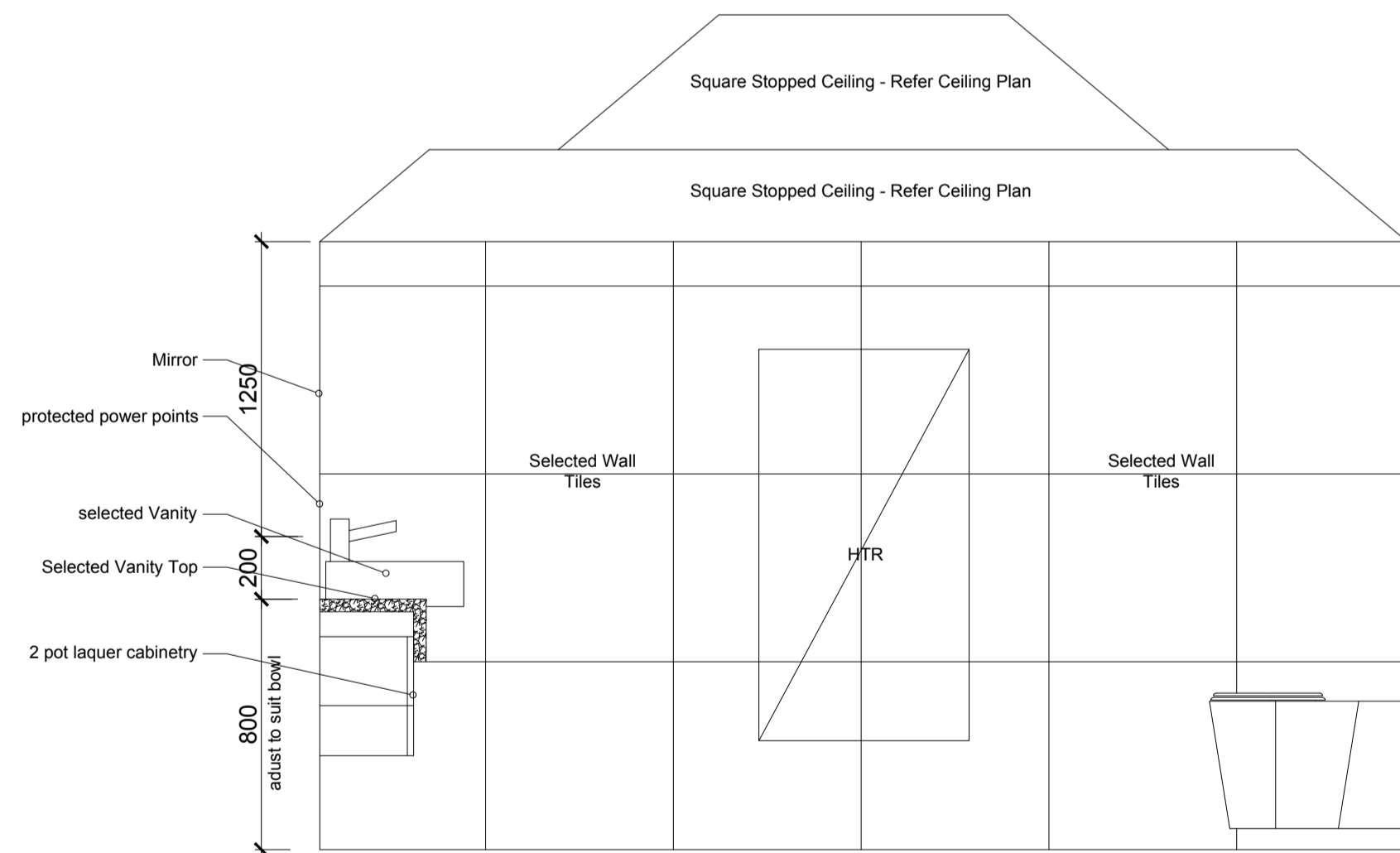

**Master Ensuite - Elevation B**  
bthrm scale 1:20

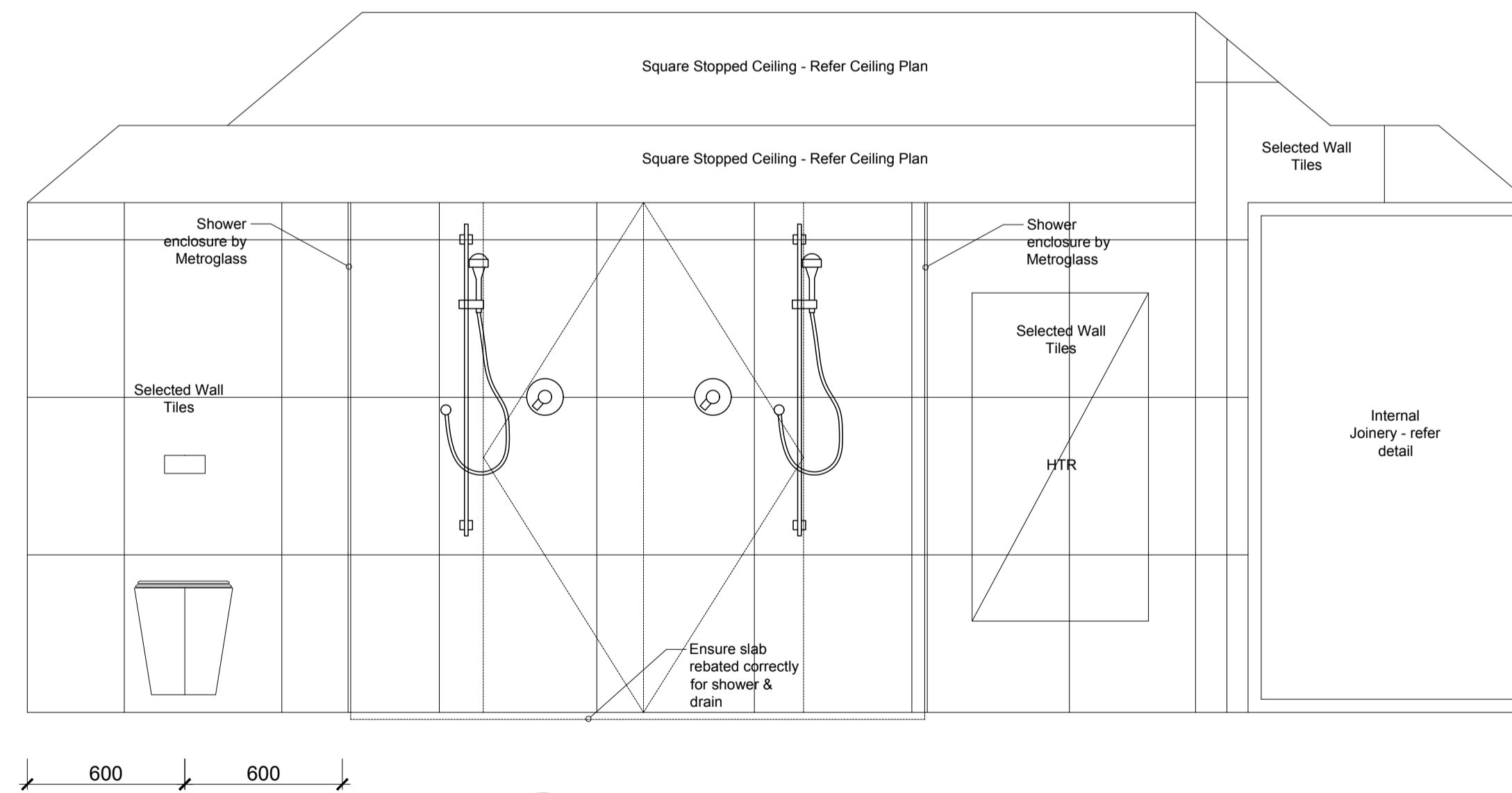

**Master Ensuite - Elevation C**  
bthrm scale 1:20

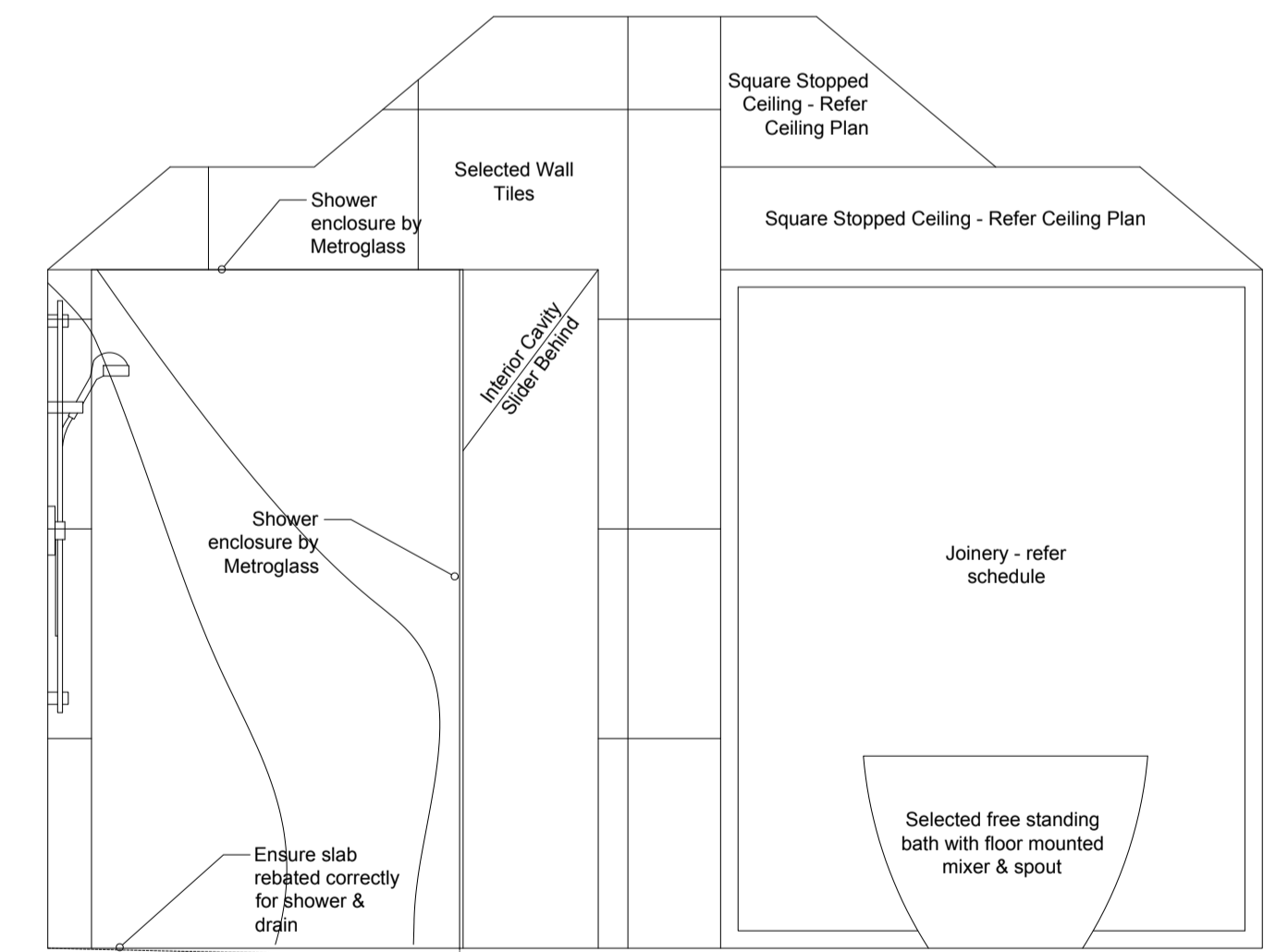

**Master Ensuite - Elevation D**  
bthrm scale 1:20

Revisions	General notes

NOTE:

**STAGE 2  
CONSENT**

59 ROSEBERRY AVE BIRKENHEAD AUCKLAND TEL (09)418 2432 FAX (09)419 5142

APARTMENT DEVELOPMENT  
81 SARSFIELD STREET, HERNE BAY

APARTMENT 2  
MASTER ENSUITE

Drawing Reference  
job no: SAR  
dep no: 039

Date: DEC'17  
Scale: 1/20 @ A1  
revision: CADREF

**DELAMARE  
ARCHITECTS**

USE DIMENSIONS TO BE CHECKED ON SITE.  
DRAWING TO BE READ IN CONJUNCTION WITH ALL  
RELEVANT DOCUMENTS.  
© THE COPYRIGHT OF THIS DRAWING IS THE PROPERTY  
OF DAVID DELAMARE

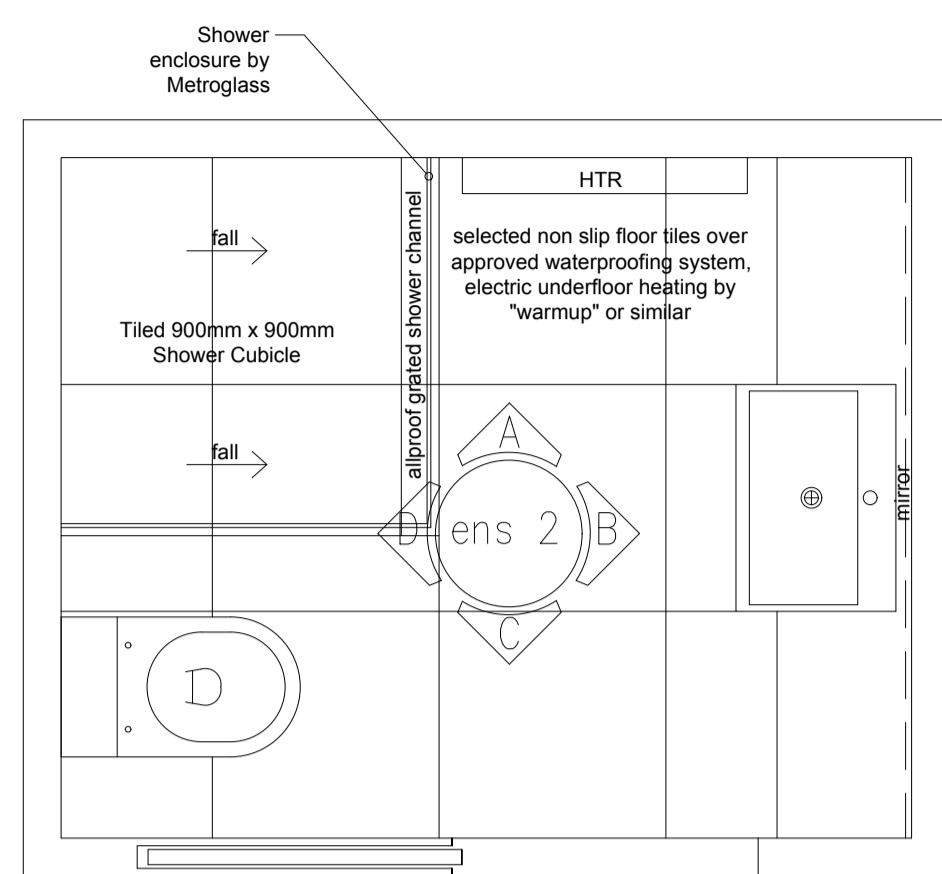

bthrm **Ensuite 2**  
scale 1:20

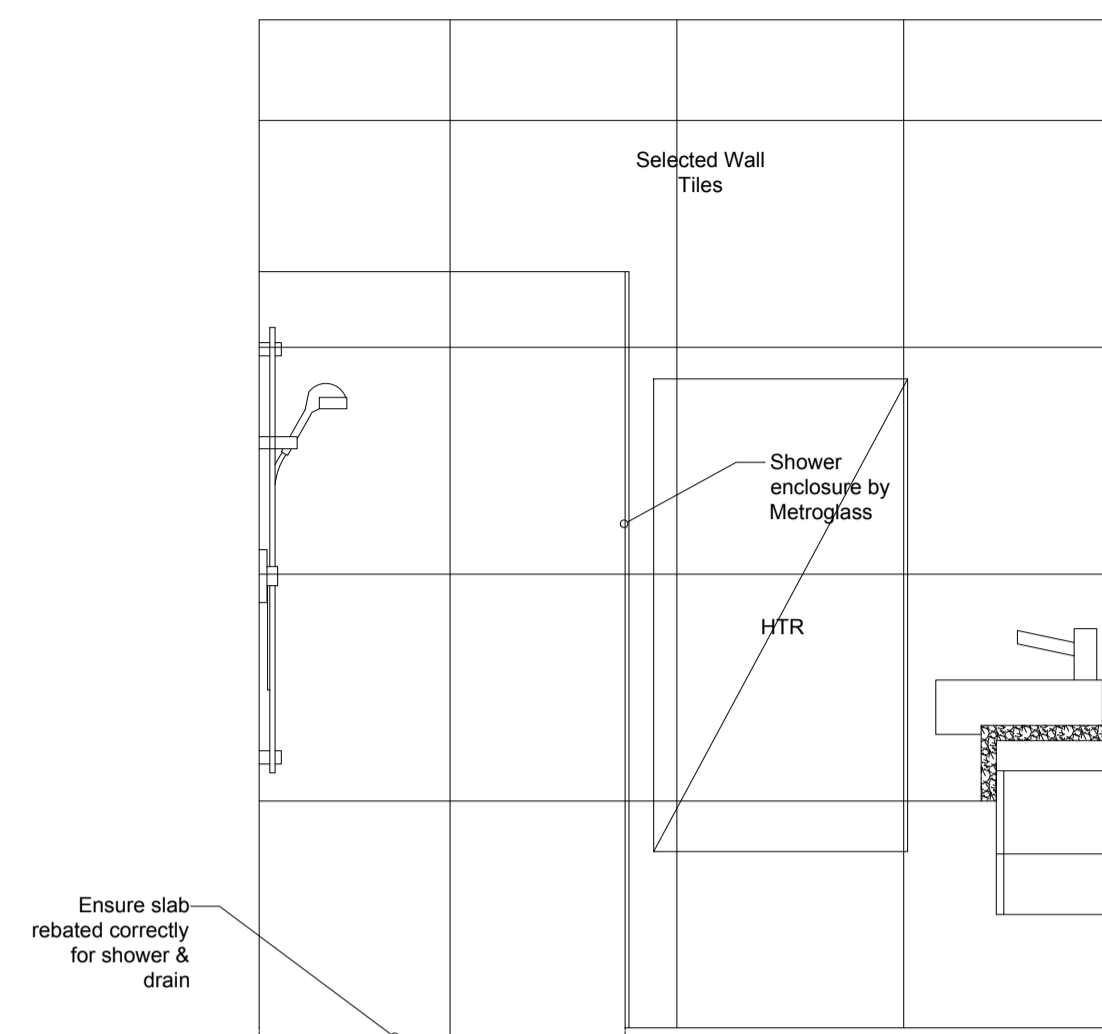

bthrm **Ensuite 2 Elevation A**  
scale 1:20

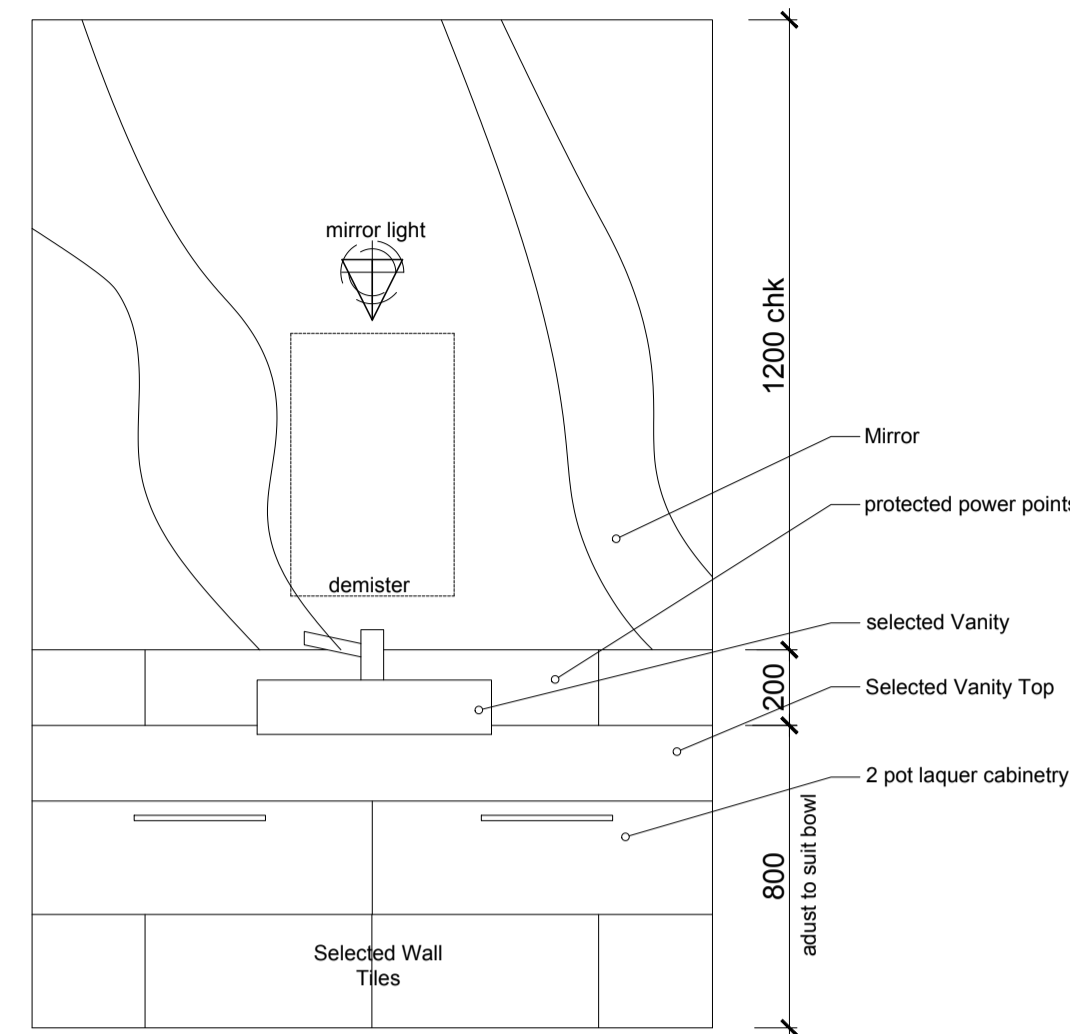

bthrm **Ensuite 2 Elevation B**  
scale 1:20

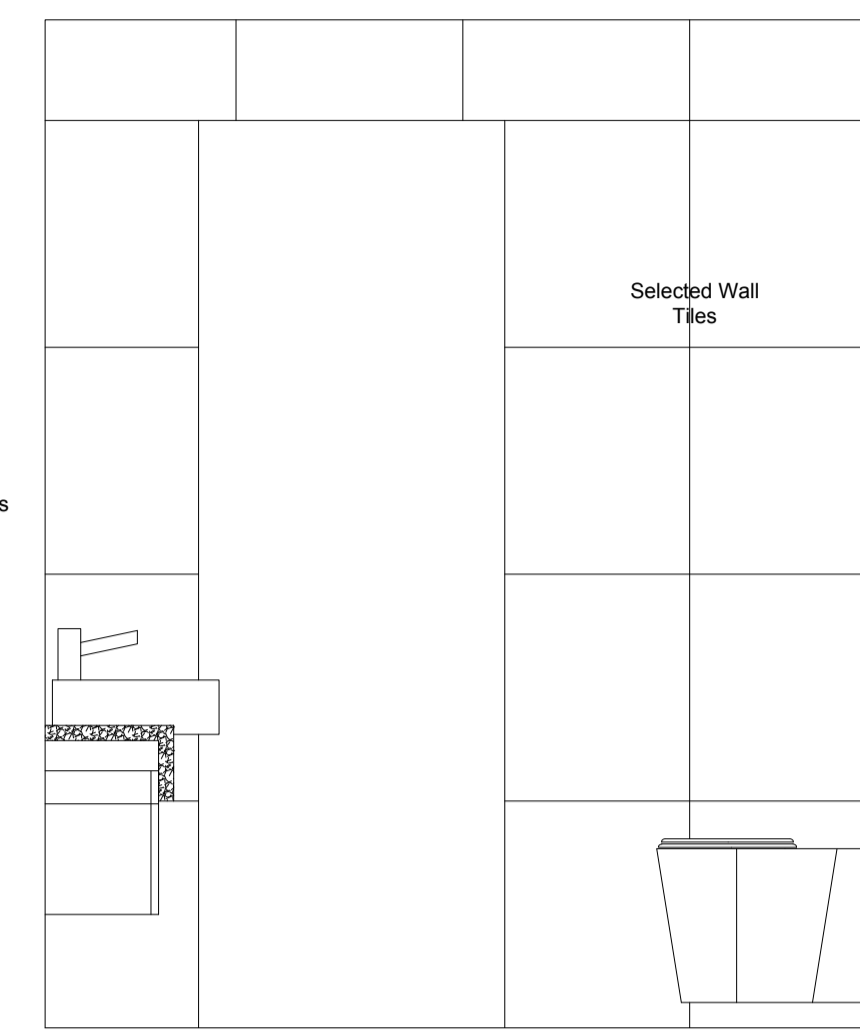

bthrm **Ensuite 2 Elevation C**  
scale 1:20

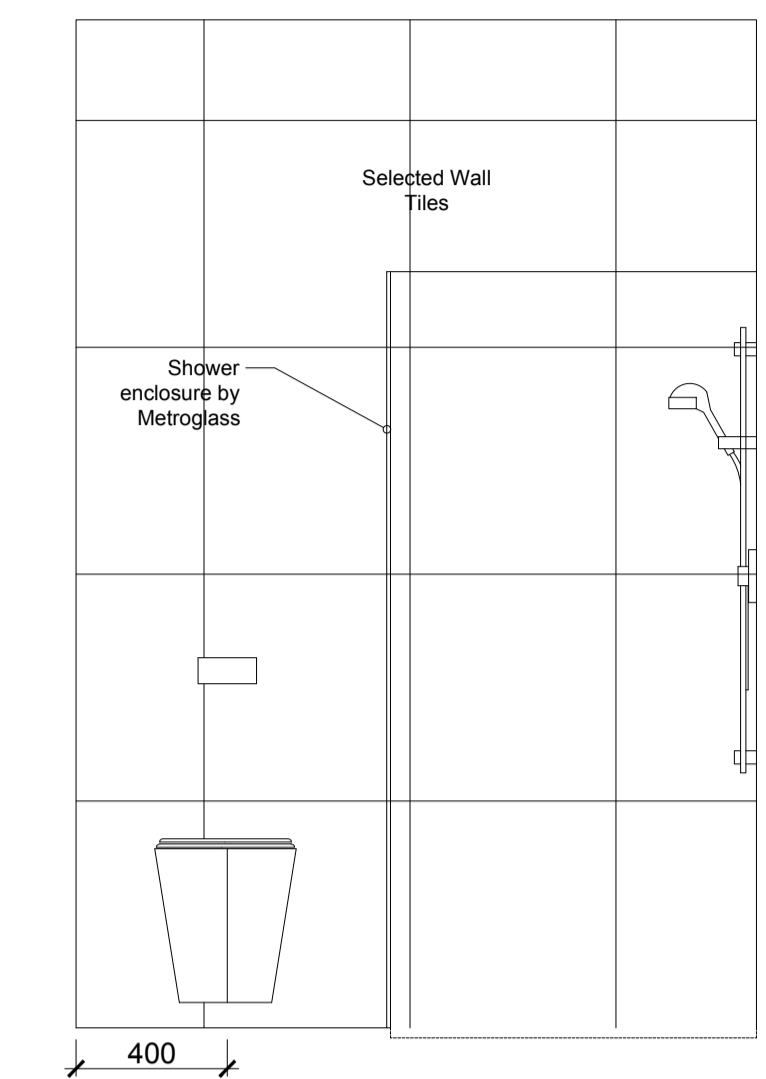

bthrm **Ensuite 2 Elevation D**  
scale 1:20

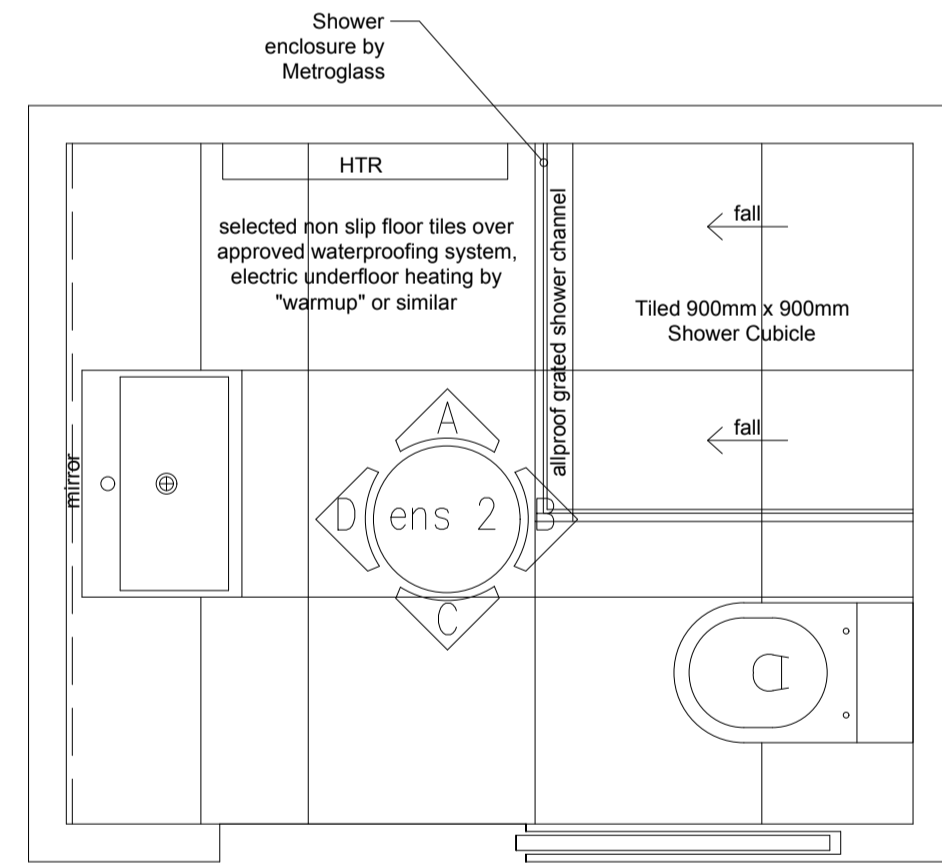

bthrm **Ensuite 3**  
scale 1:20

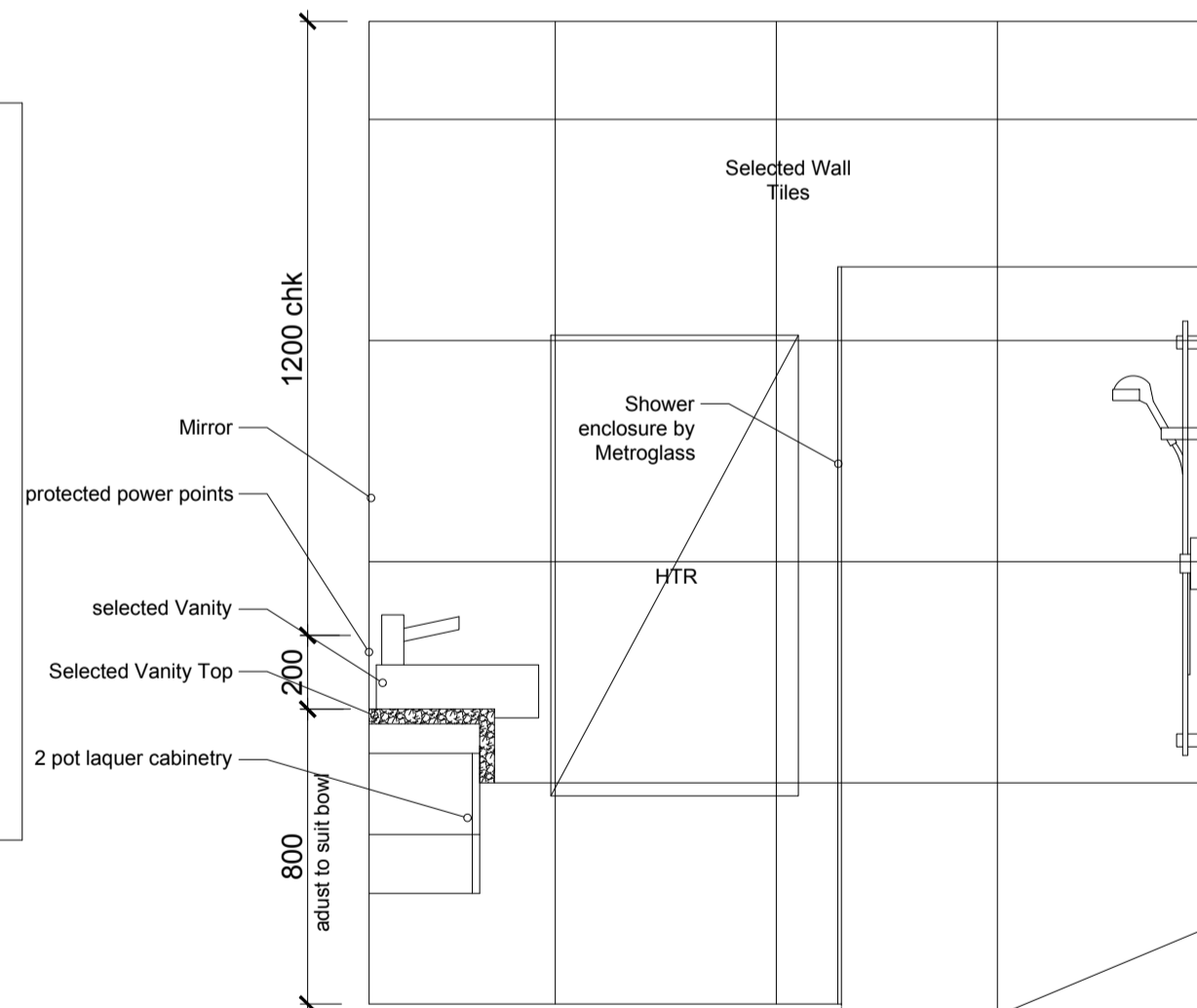

bthrm **Ensuite 3 Elevation A**  
scale 1:20

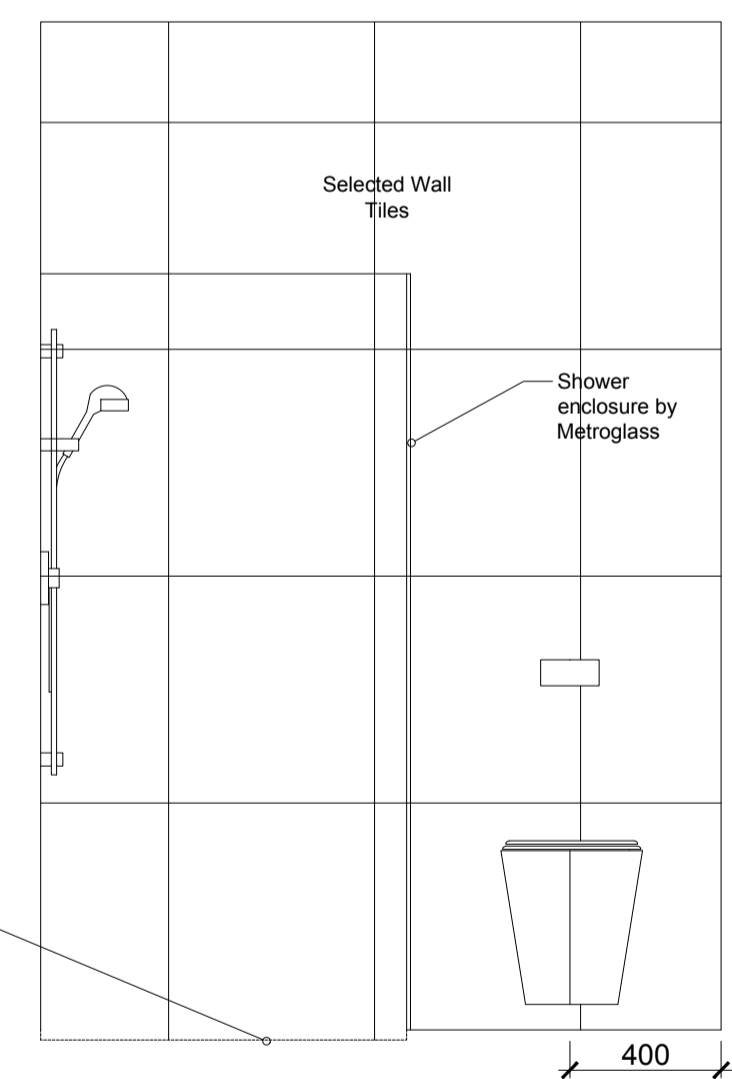

bthrm **Ensuite 3 Elevation B**  
scale 1:20

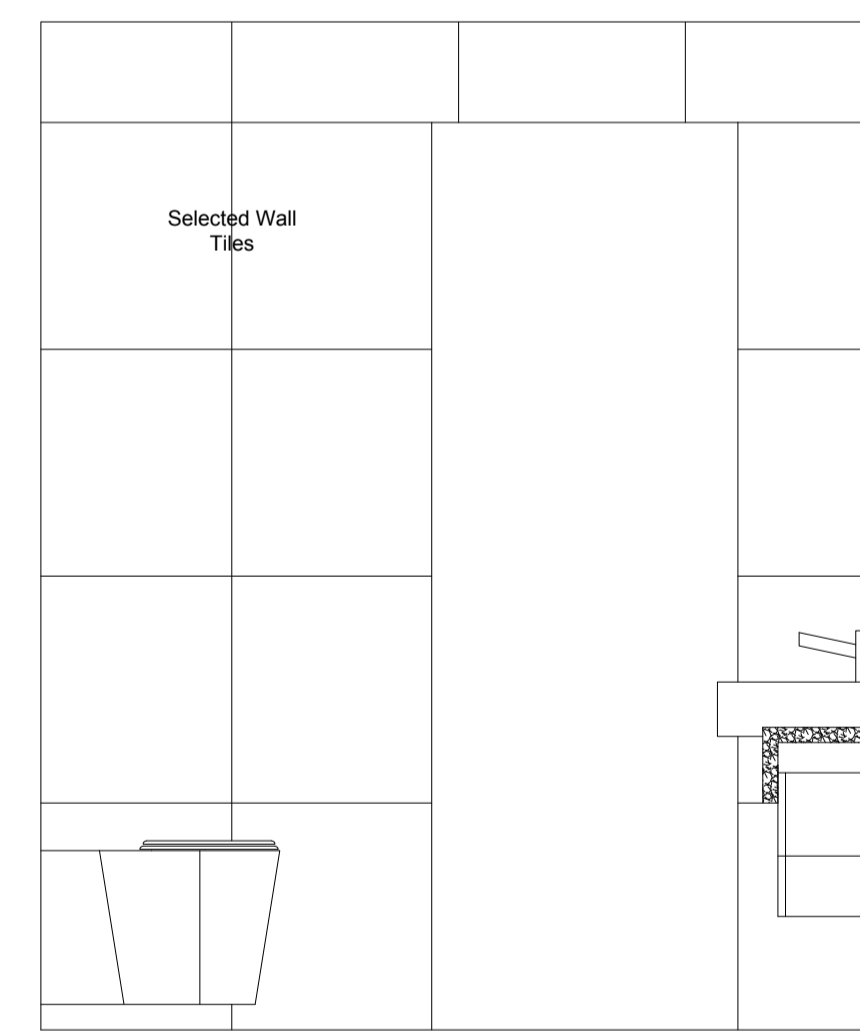

bthrm **Ensuite 3 Elevation C**  
scale 1:20

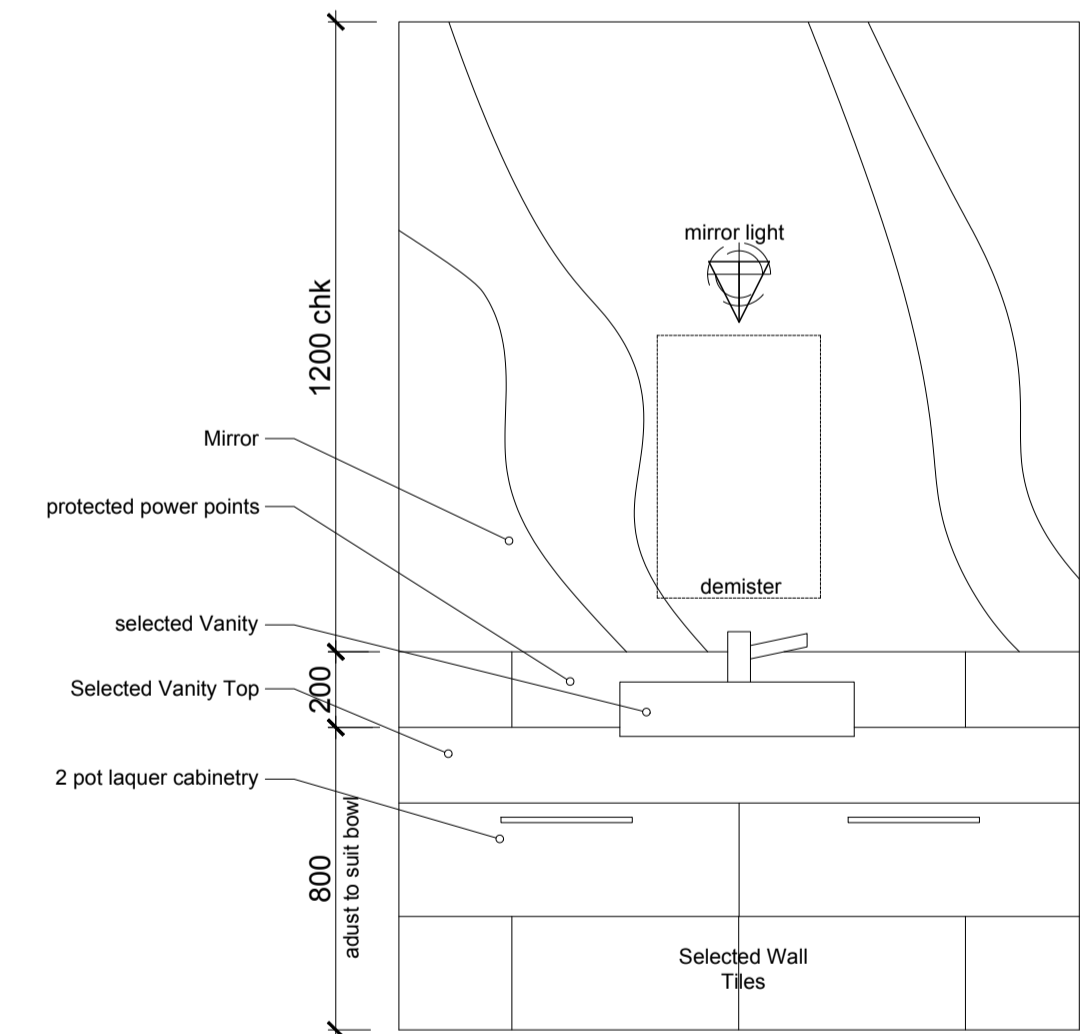

bthrm **Ensuite 3 Elevation D**  
scale 1:20

Revisions	General notes

NOTE:  
**STAGE 2  
CONSENT**

59 ROSEBERRY AVE BIRKENHEAD AUCKLAND TEL (09)418 2432 FAX (09)419 5142  
 APARTMENT DEVELOPMENT  
 81 SANSFIELD STREET, HERNE BAY

**DELAMARE ARCHITECTS**

Date DEC'17  
 Scale 1/20 @ A1  
 Drawing Reference  
 APARTMENT 2  
 ENSUITES  
 Job no. SAR  
 Desig no. 040  
 revision  
 Cod ref SAR  
 CADREF

USE DIMENSIONS: DO NOT SCALE FROM DRAWING. ALL LEVELS AND DIMENSIONS TO BE CHECKED ON SITE. DRAWING TO BE READ IN CONJUNCTION WITH ALL RELEVANT DOCUMENTS. © THE COPYRIGHT OF THIS DRAWING IS THE PROPERTY OF DAVID DELAMARE.



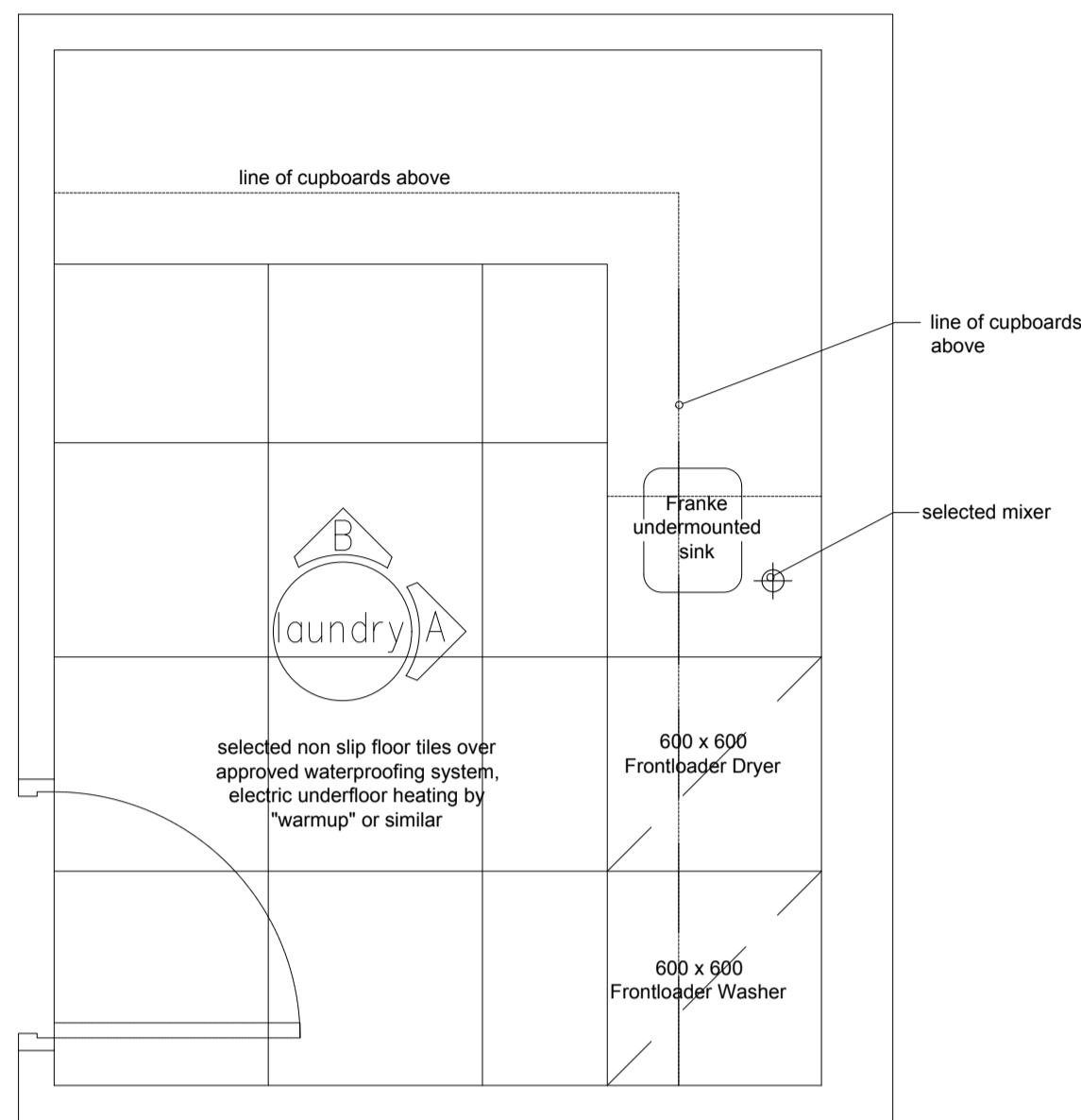

**Laundry 2**  
bthrm scale 1:20

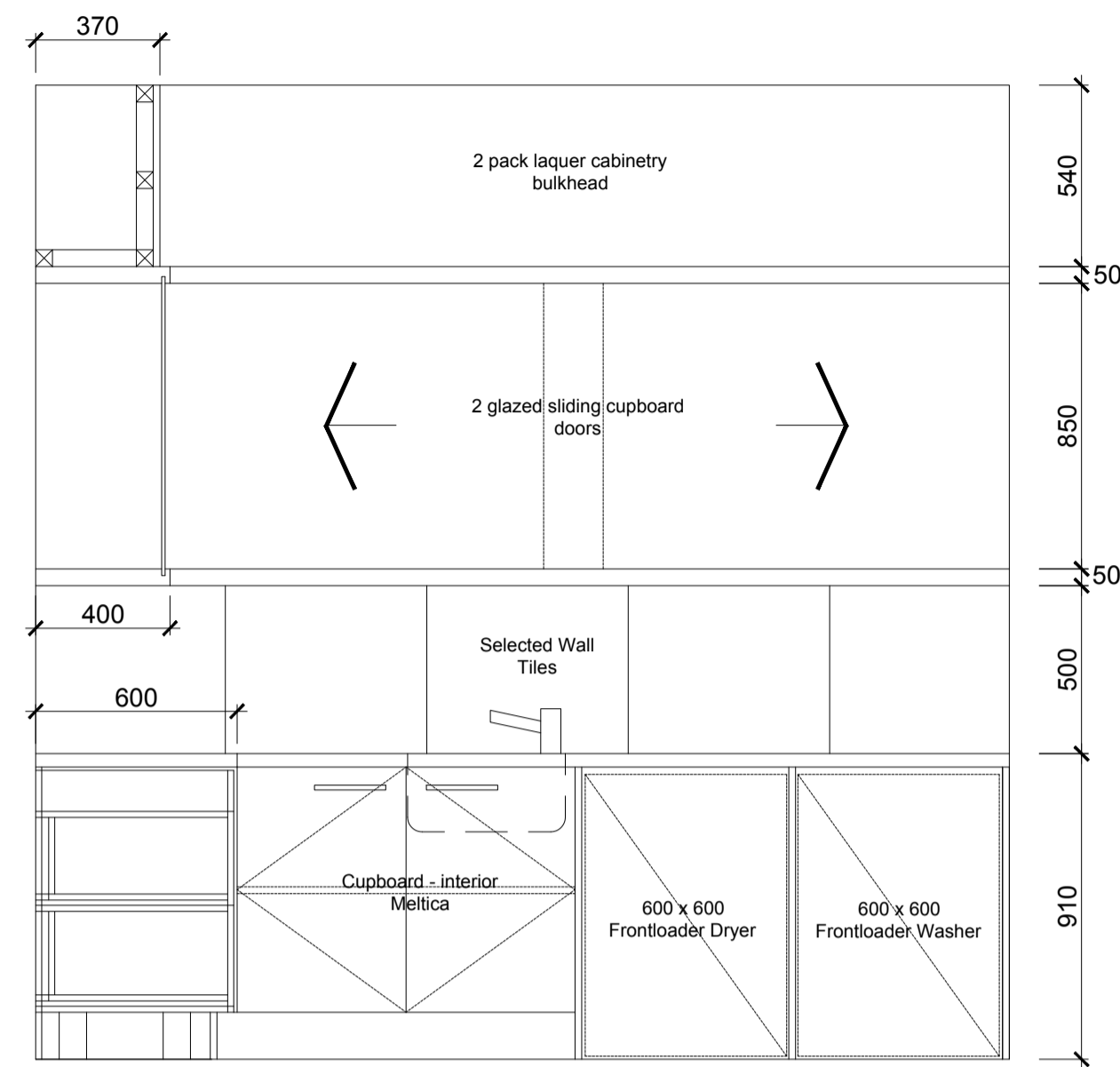

**Laundry 2 Elevation A**  
bthrm scale 1:20

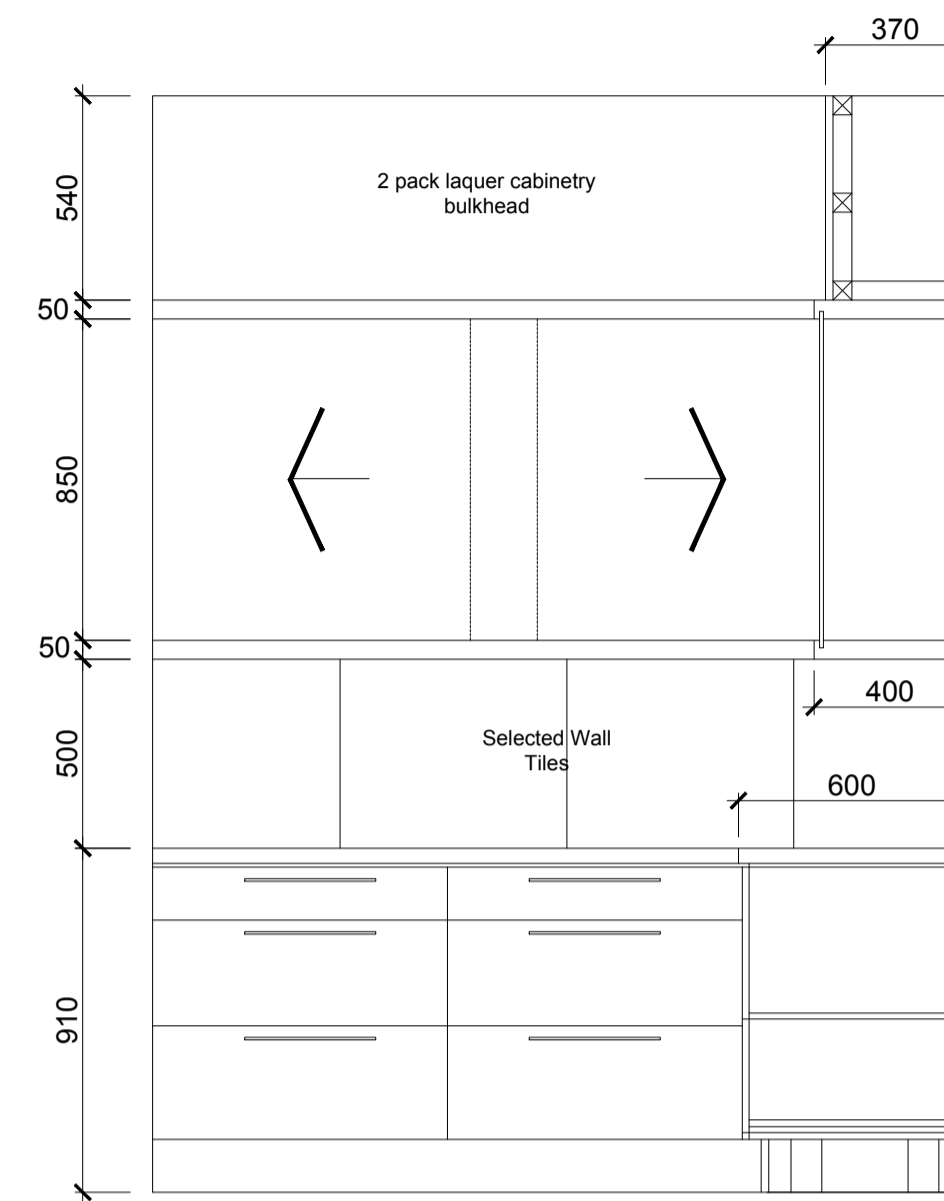

**Laundry 2 Elevation B**  
bthrm scale 1:20

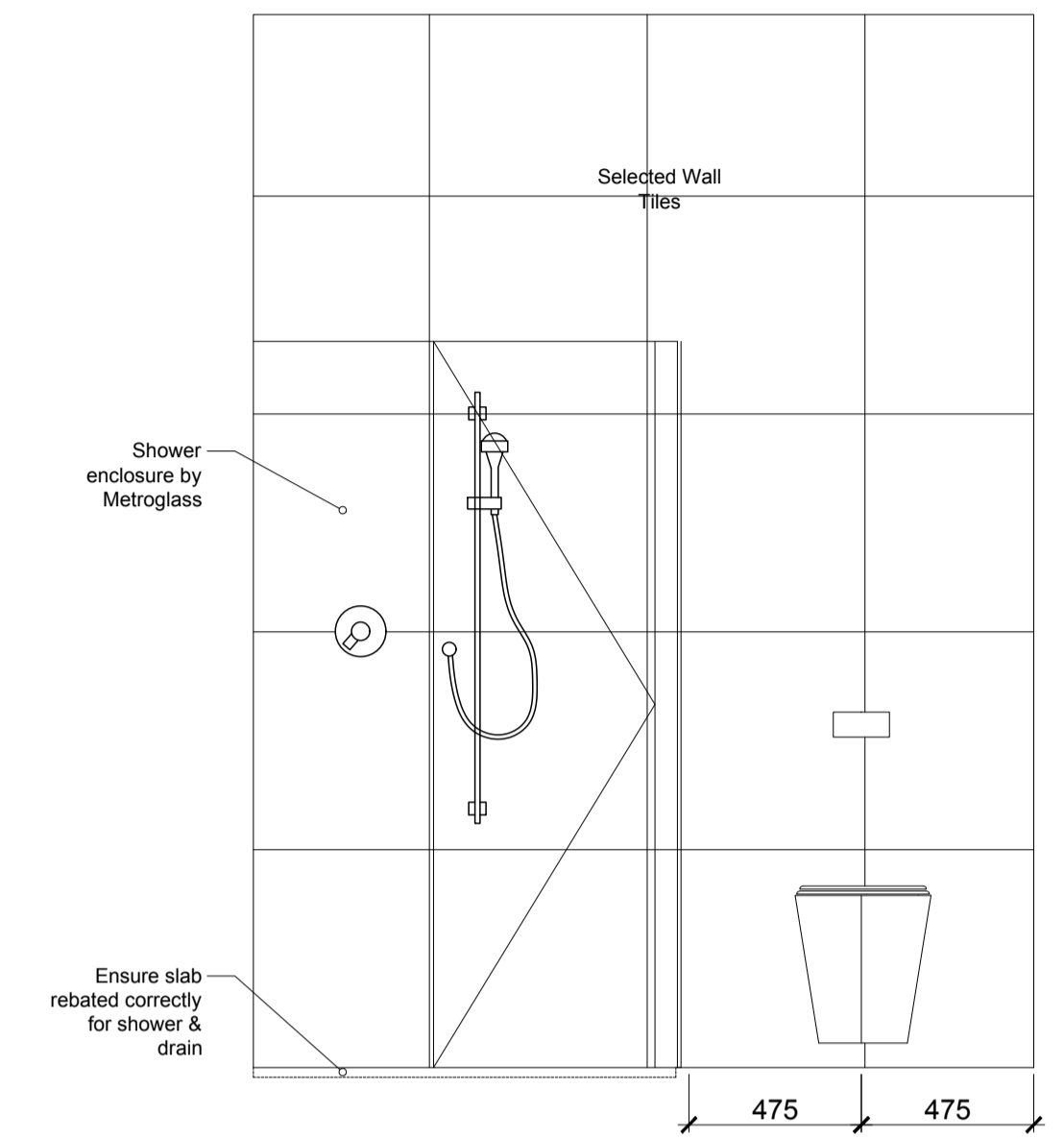

**Shower Room Elevation D**  
bthrm scale 1:20

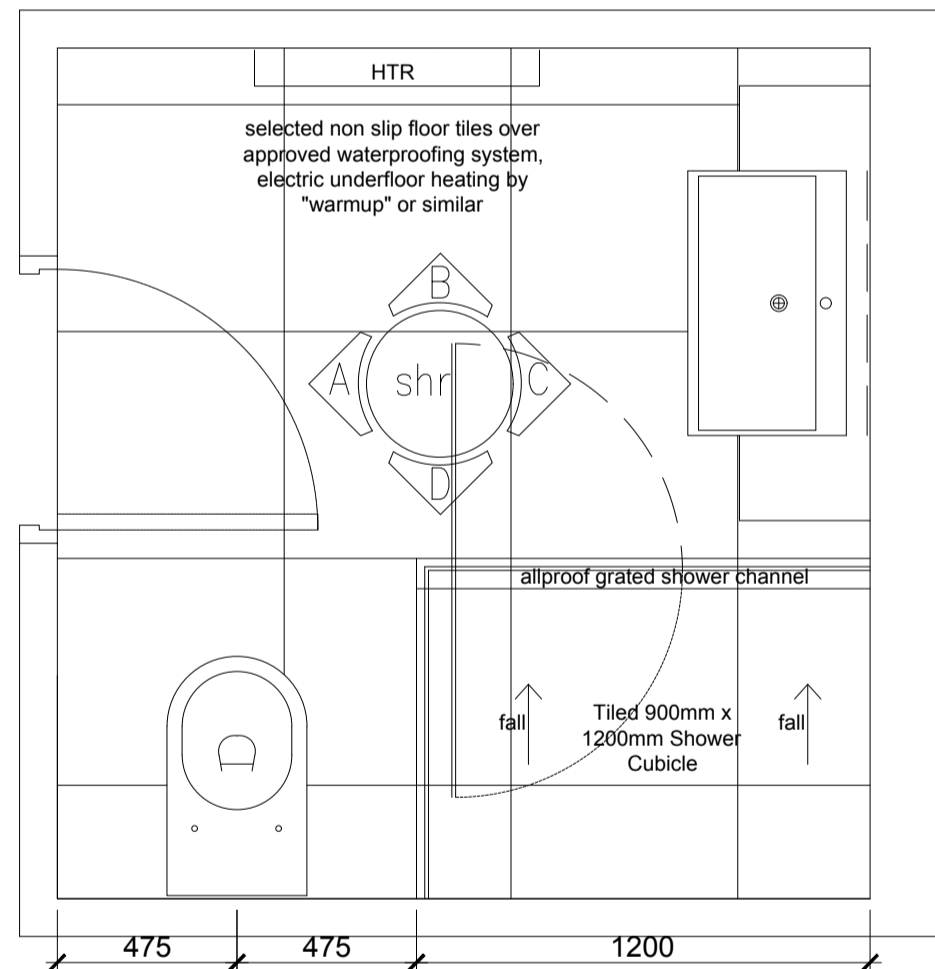

**Shower Room**  
bthrm scale 1:20

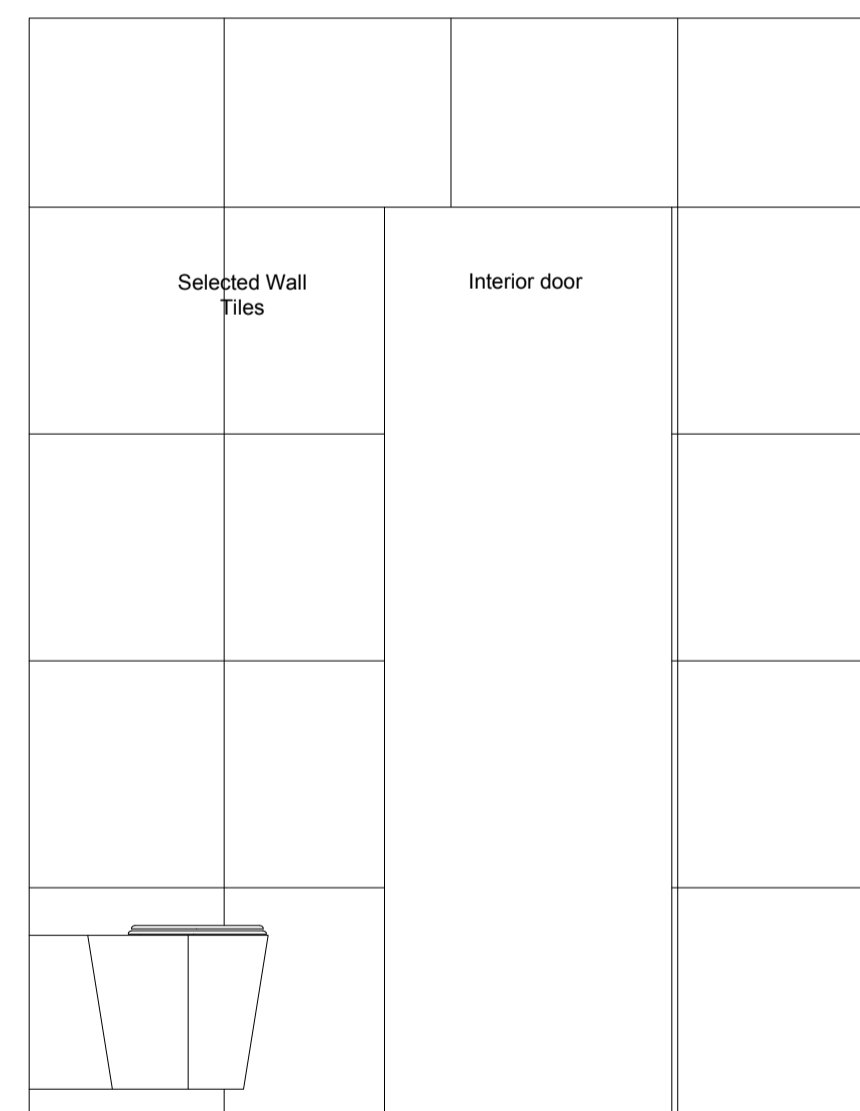

**Shower Room Elevation A**  
bthrm scale 1:20

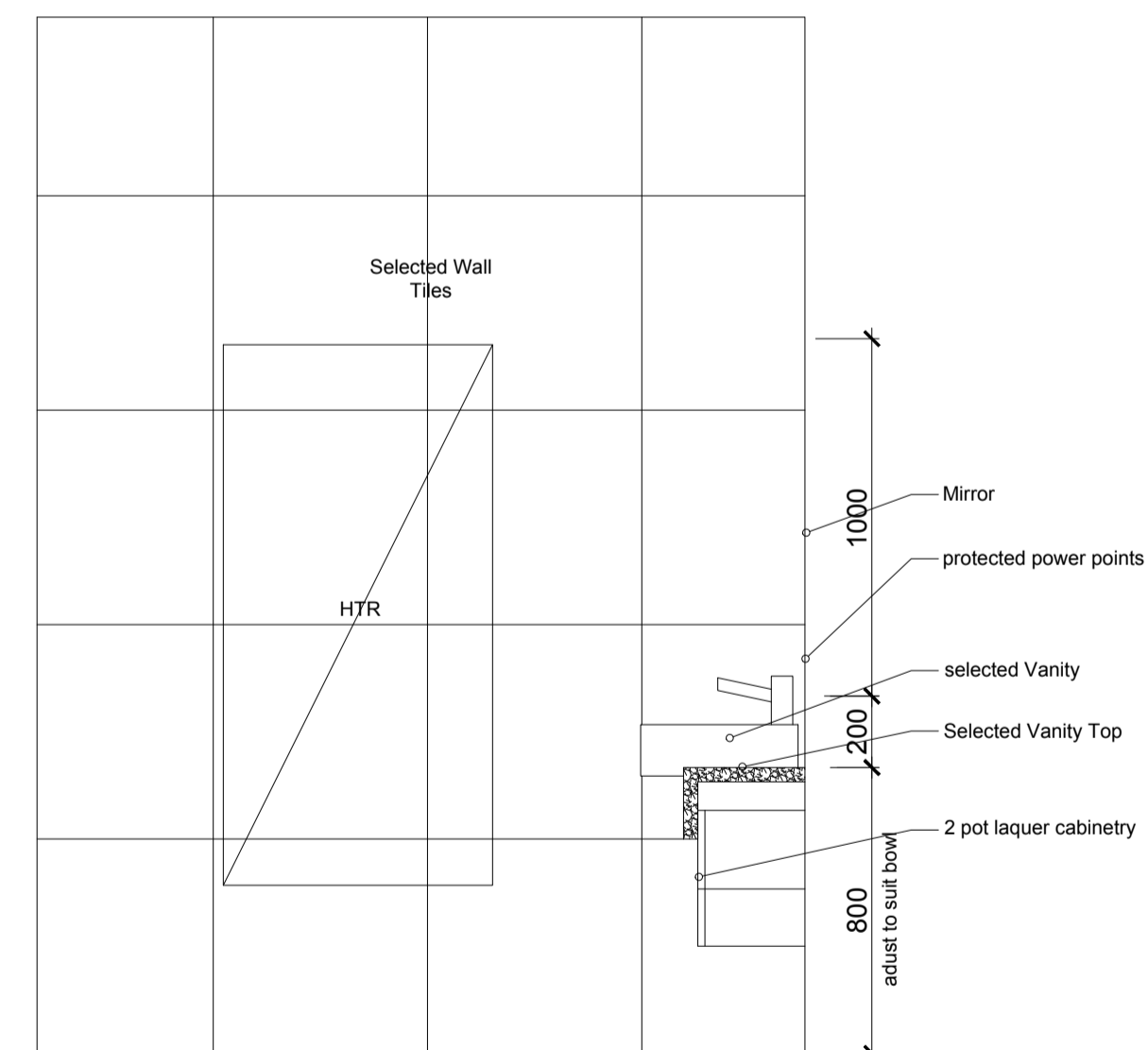

**Shower Room Elevation B**  
bthrm scale 1:20

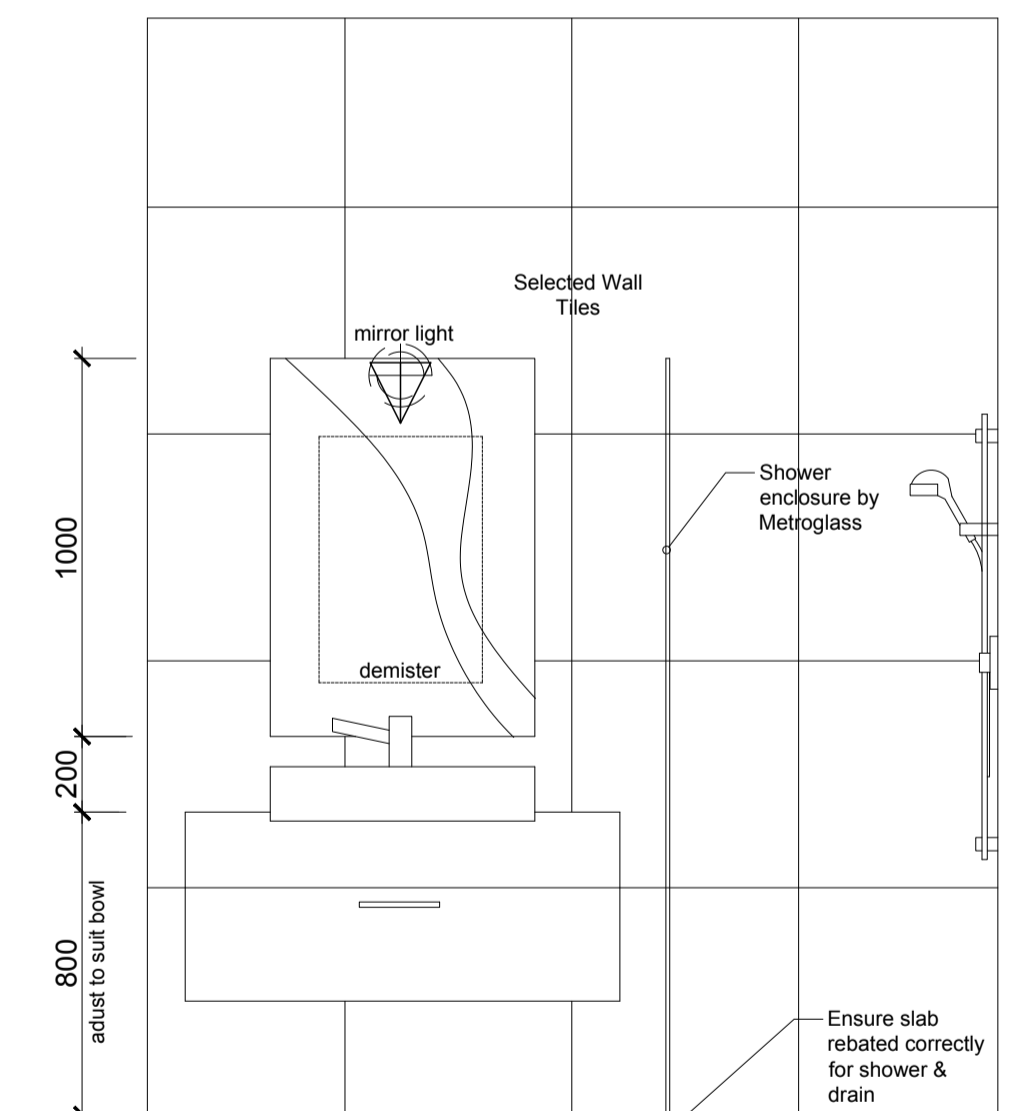

**Shower Room Elevation C**  
bthrm scale 1:20

Revisions	General notes

NOTE:

**STAGE 2  
CONSENT**

59 ROSEBERRY AVE BIRKENHEAD AUCKLAND TEL (09)418 2432 FAX (09)419 5142

APARTMENT DEVELOPMENT  
81 SARSFIELD STREET, HERNE BAY

**DELAMARE ARCHITECTS**

Date DEC'17  
Scale 1/20 @ A1  
Drawing Reference  
APARTMENT 2  
BATH & LAUNDRY  
job no. SAR  
dep no. 041  
revision  
Cod ref SAR  
CADREF

USE FIGURED DIMENSIONS. DO NOT SCALE FROM DRAWING.  
ALL LEVELS AND DIMENSIONS TO BE CHECKED ON SITE.  
DRAWING TO BE READ IN CONJUNCTION WITH ALL RELEVANT DOCUMENTS.  
©THE CONTENT OF THIS DRAWING IS THE PROPERTY OF DAVID DELAMARE

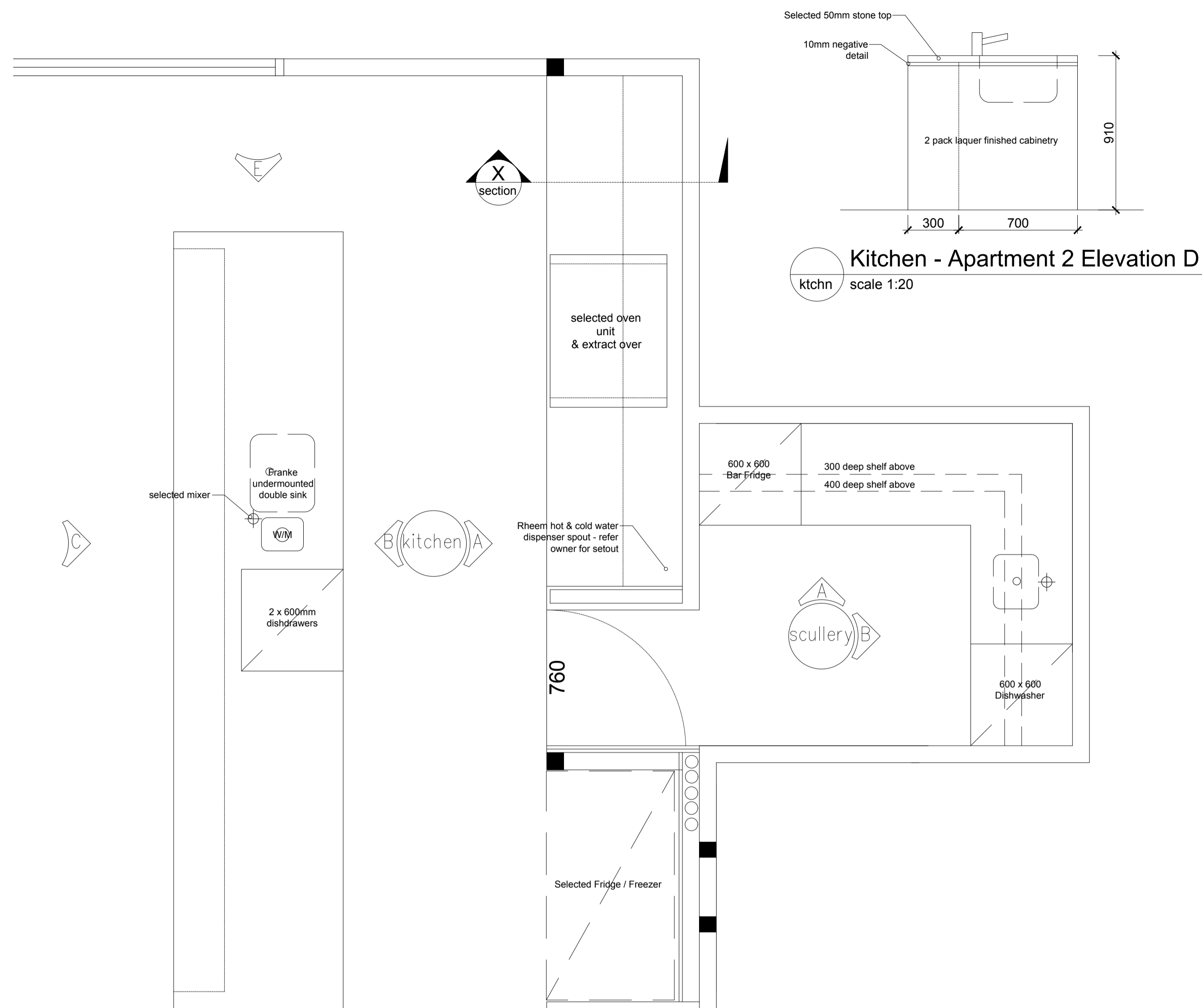

**Kitchen - Apartment 2**  
ktchn scale 1:20

**Kitchen - Apartment 2 Elevation D**  
ktchn scale 1:20

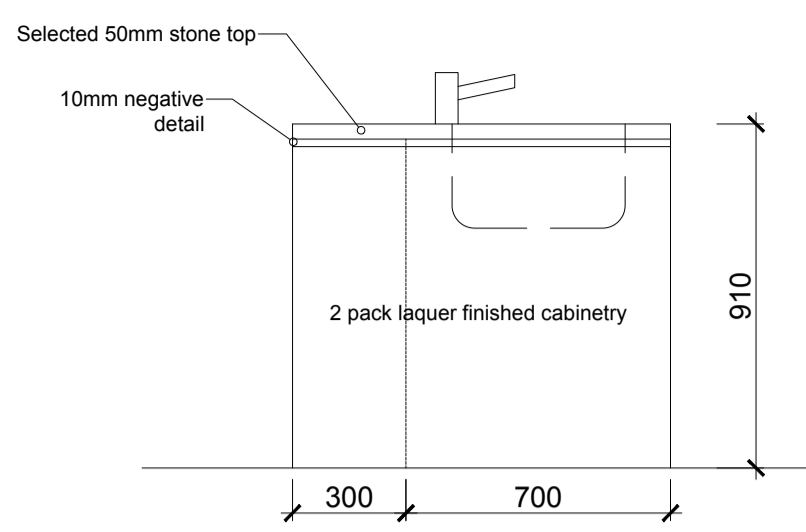

**Kitchen - Apartment 2 Elevation E**  
ktchn scale 1:20

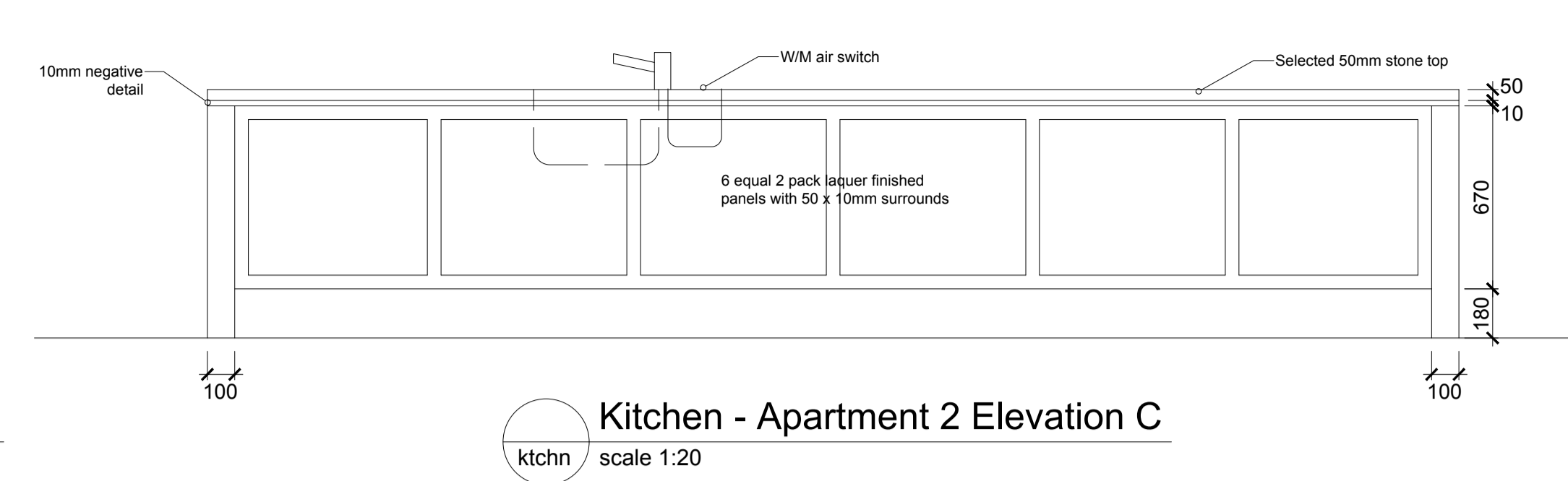
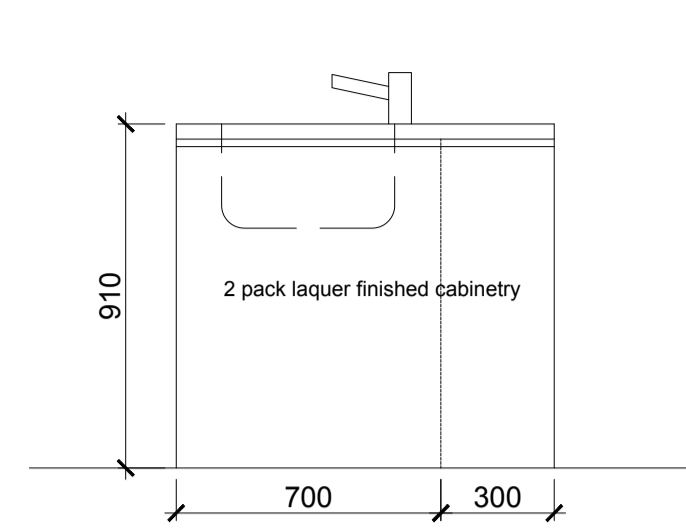

**Kitchen - Apartment 2 Elevation C**  
ktchn scale 1:20

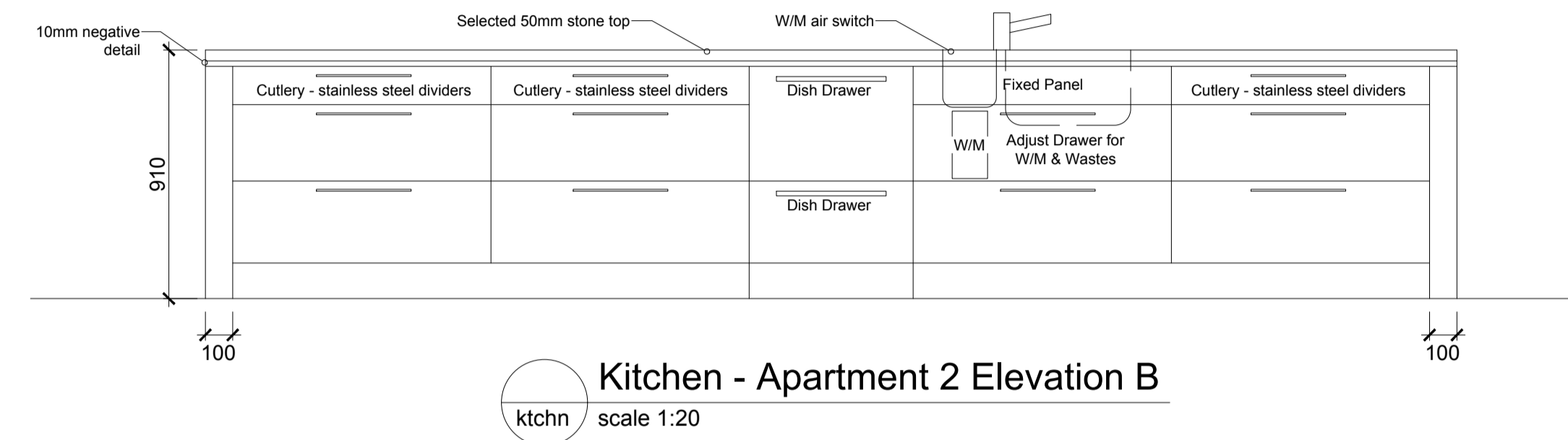

**Kitchen - Apartment 2 Elevation B**  
ktchn scale 1:20

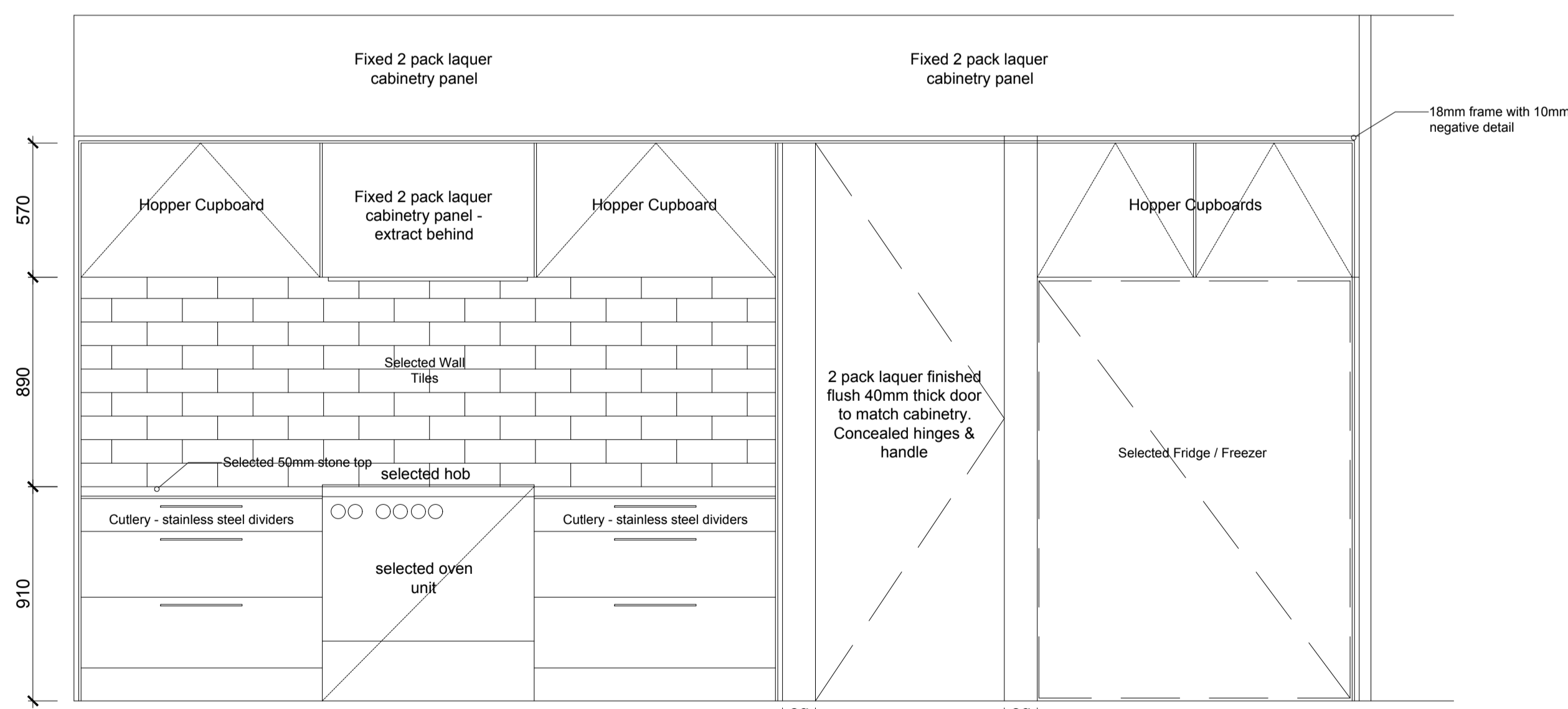

**Kitchen - Apartment 2 Elevation A**  
ktchn scale 1:20

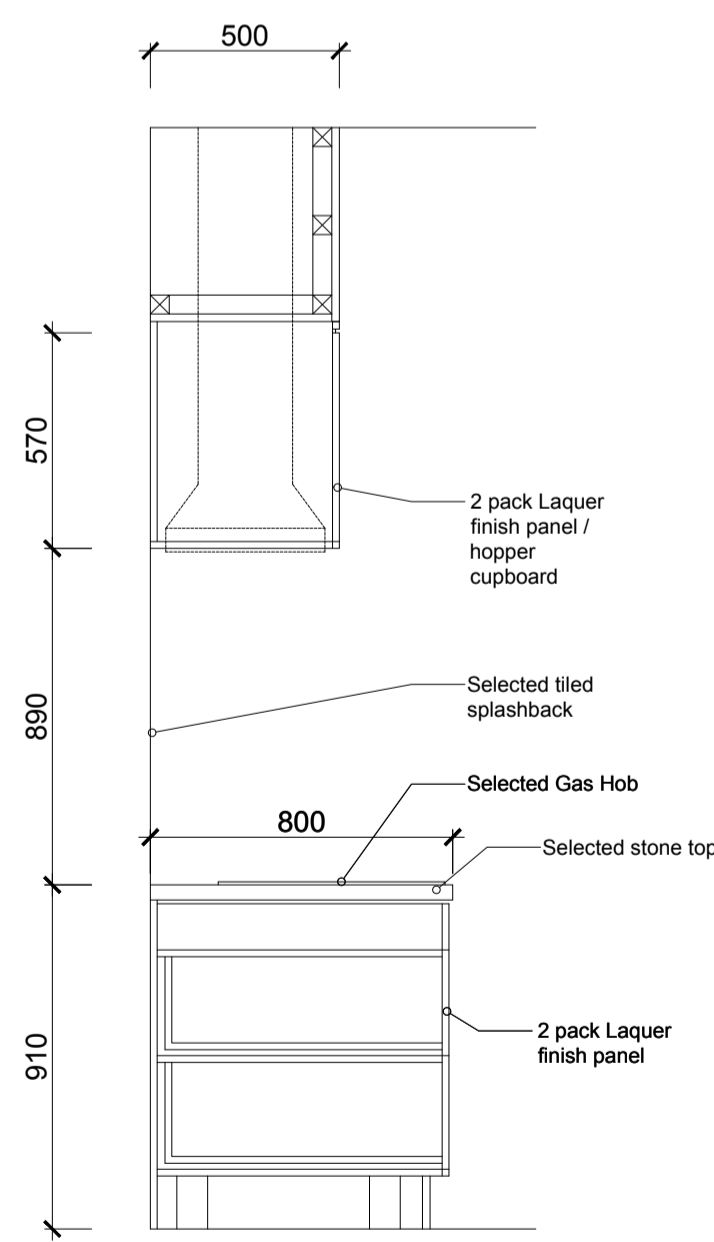

**X Kitchen Section**  
ktchn scale 1:20

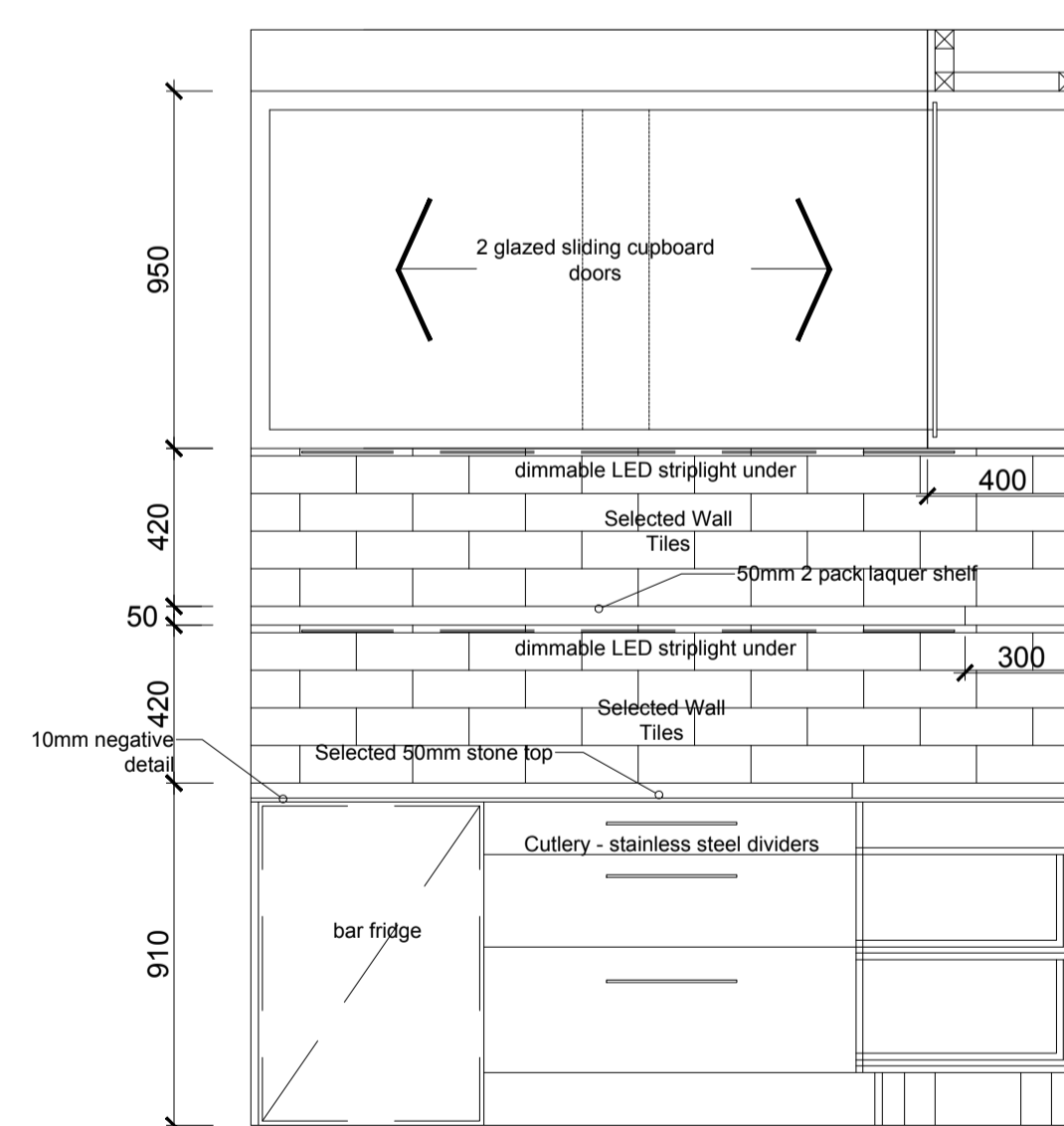

**Scullery Elevation A**  
ktchn scale 1:20

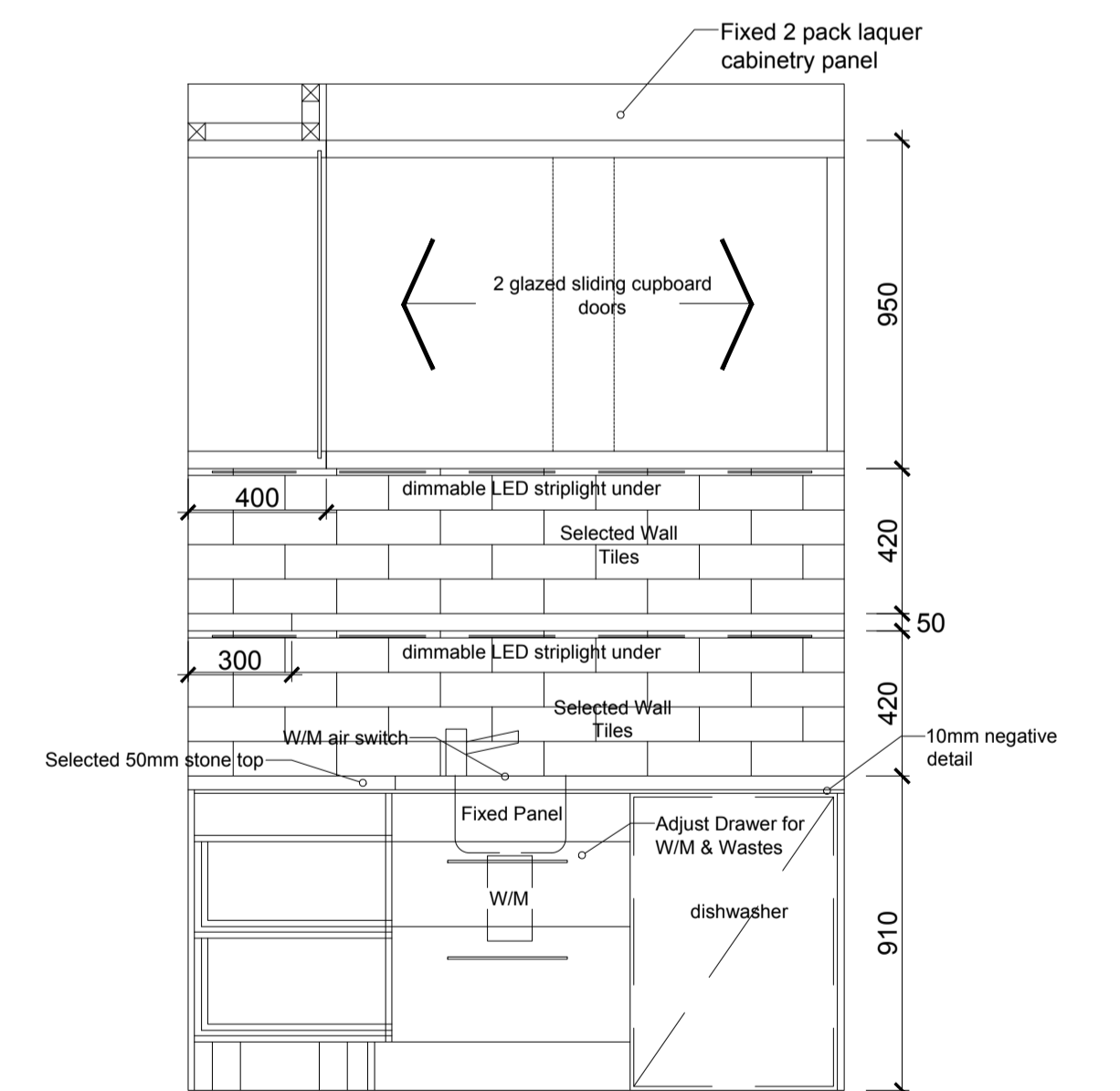

**Scullery Elevation B**  
ktchn scale 1:20

Revisions	General notes

NOTE:

**STAGE 2  
CONSENT**

59 ROSEBERRY AVE BIRKENHEAD AUCKLAND TEL (09)418 2432 FAX (09)419 5142

APARTMENT DEVELOPMENT  
81 SANSFIELD STREET, HERNE BAY

APARTMENT 2  
KITCHEN

Drawing Reference  
job no: SAR  
dep no: 042  
revision: CADREF

Date: DEC'17  
Scale: 1/20 @ A1  
Cod ref: SAR

**DELAMARE  
ARCHITECTS**

USE FOURED DIMENSIONS. DO NOT SCALE FROM DRAWING.  
ALL LEVELS AND DIMENSIONS TO BE CHECKED ON SITE.  
DRAWING TO BE READ IN CONJUNCTION WITH ALL  
RELEVANT DOCUMENTS.  
© THE CONTENT OF THIS DRAWING IS THE PROPERTY  
OF DAVID DELAMARE

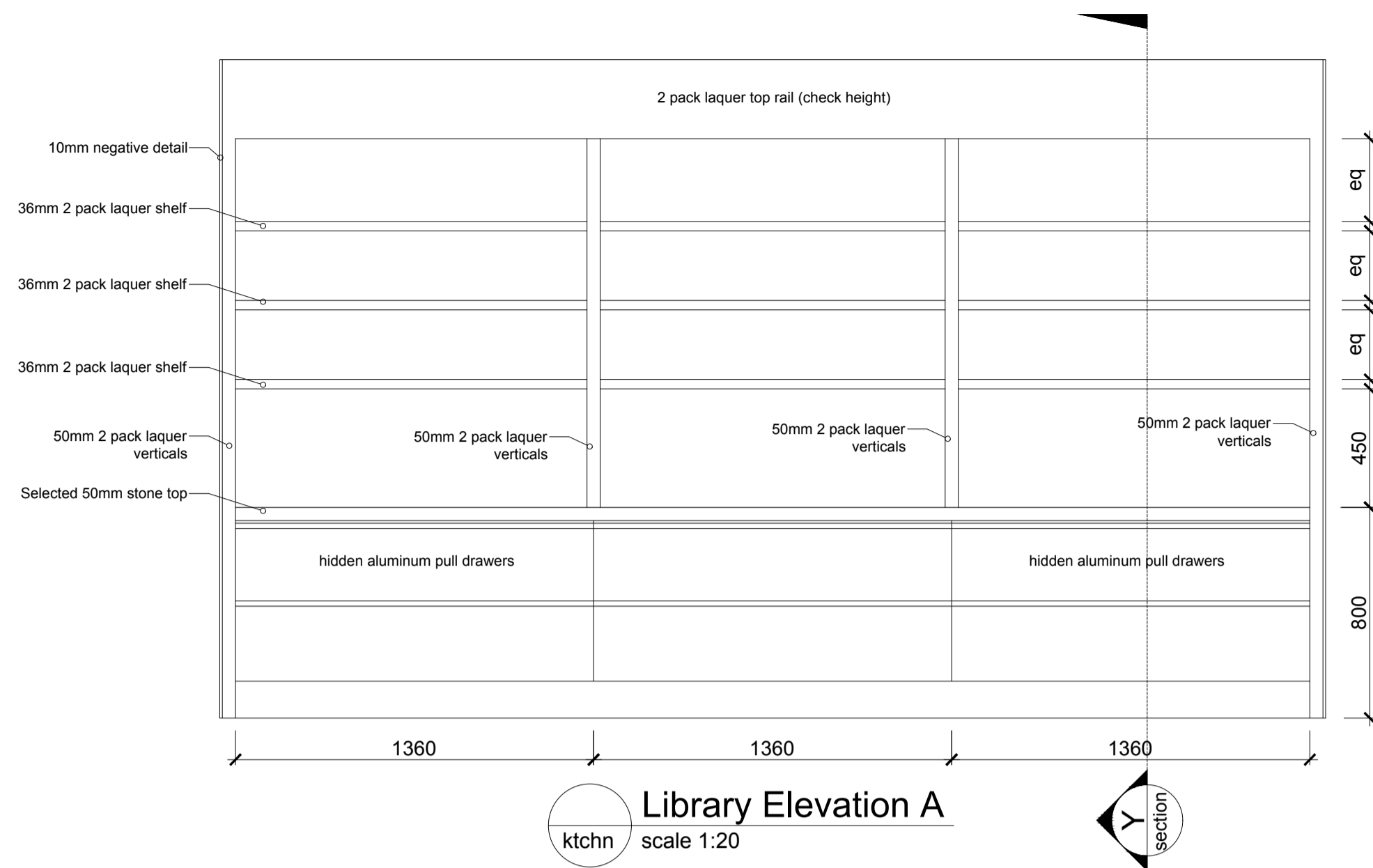

**Library Elevation A**  
scale 1:20

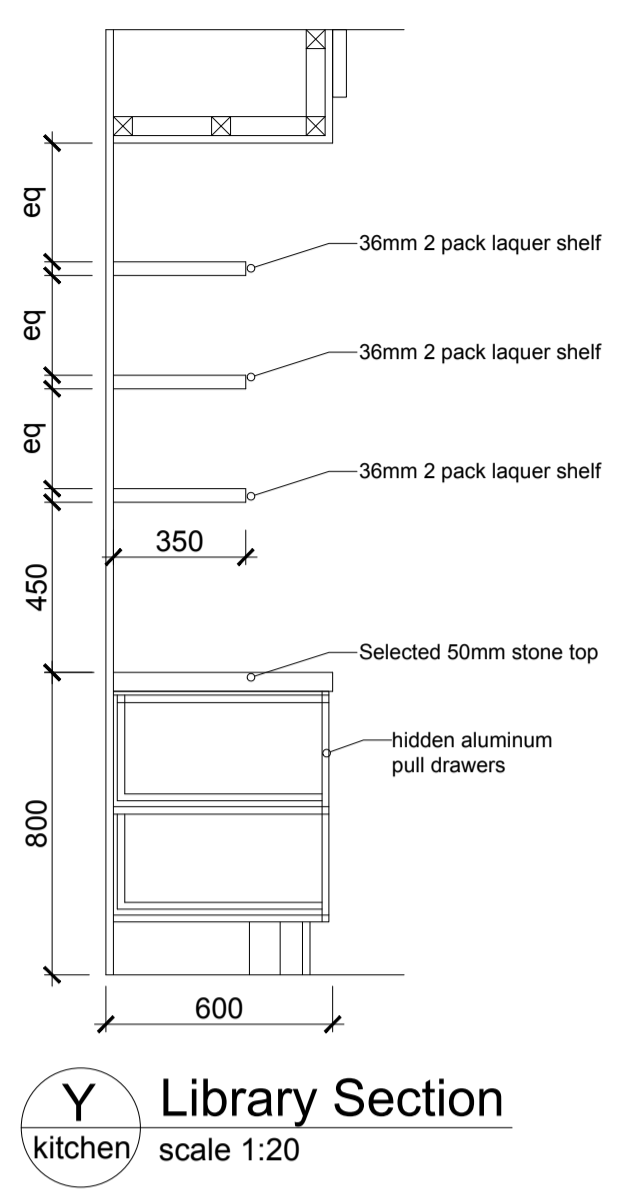

**Library Section**  
scale 1:20

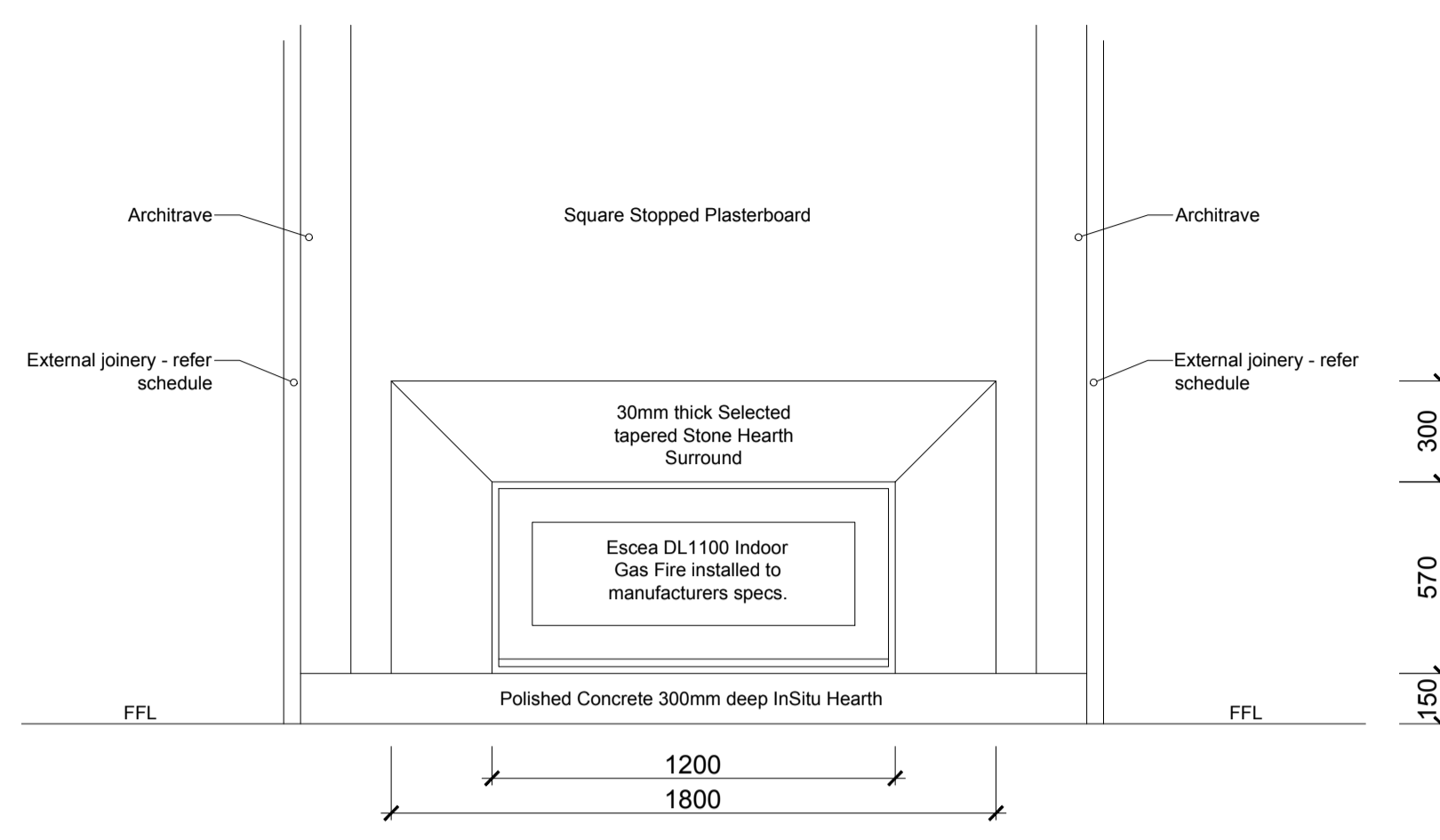

**Apartment 2 - Living Room Fireplace**  
scale 1:20

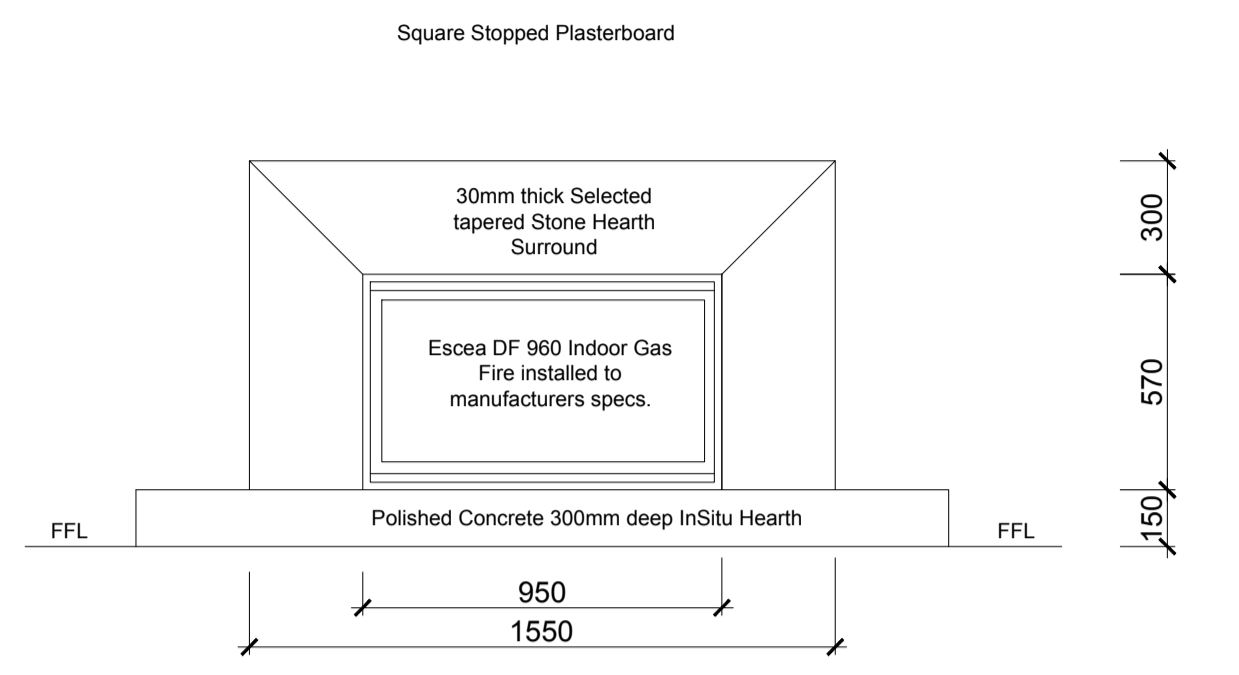

**Apartment 2 - Media Room Fireplace**  
scale 1:20

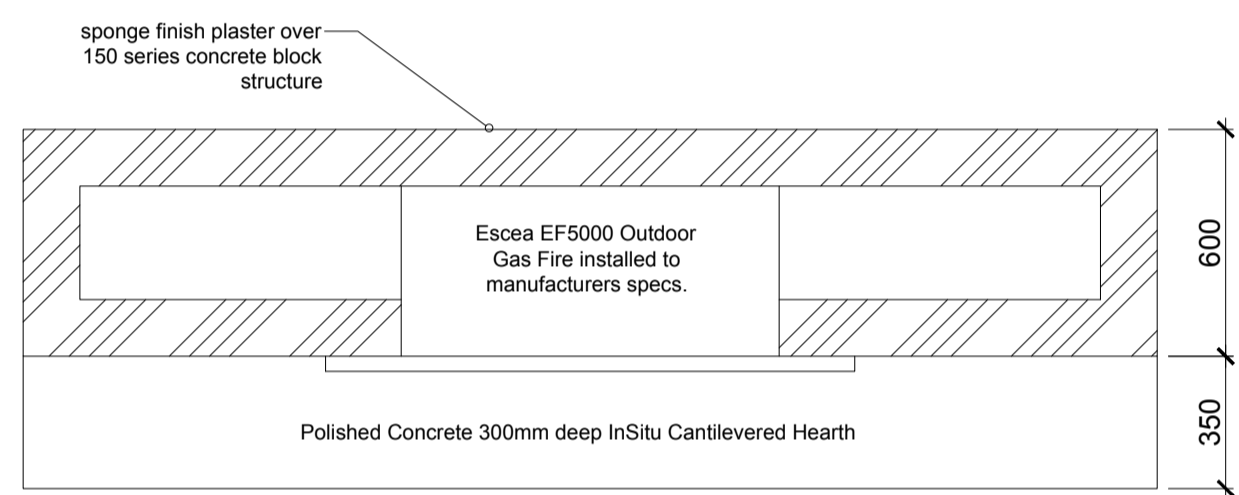

**Louvretec Outdoor Fire**  
scale 1:20

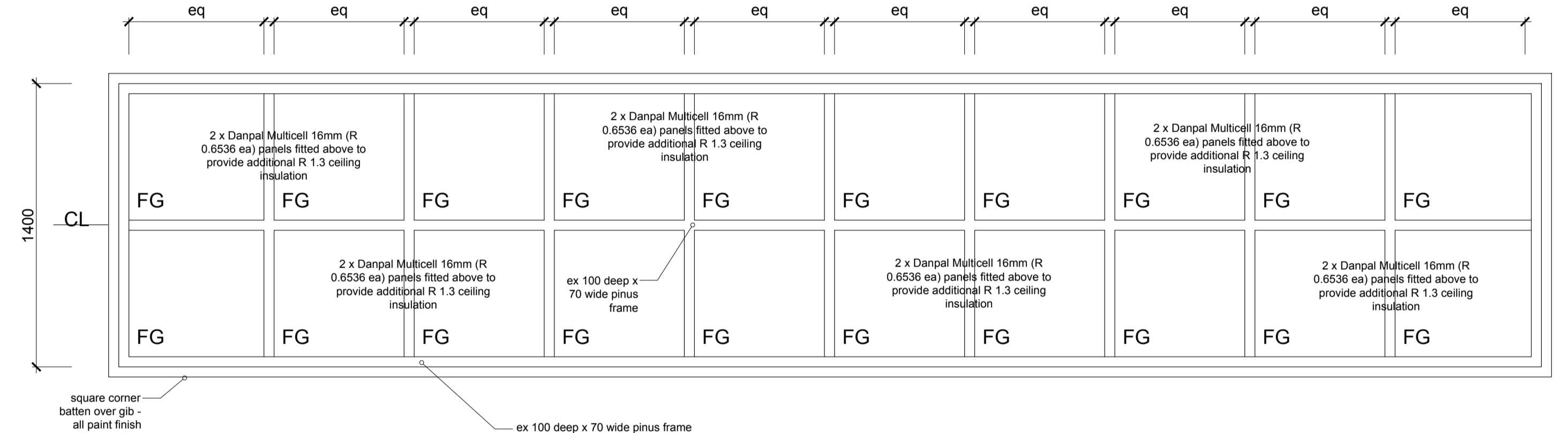

**Rooflight Plan - Apartment 2**  
scale 1:20

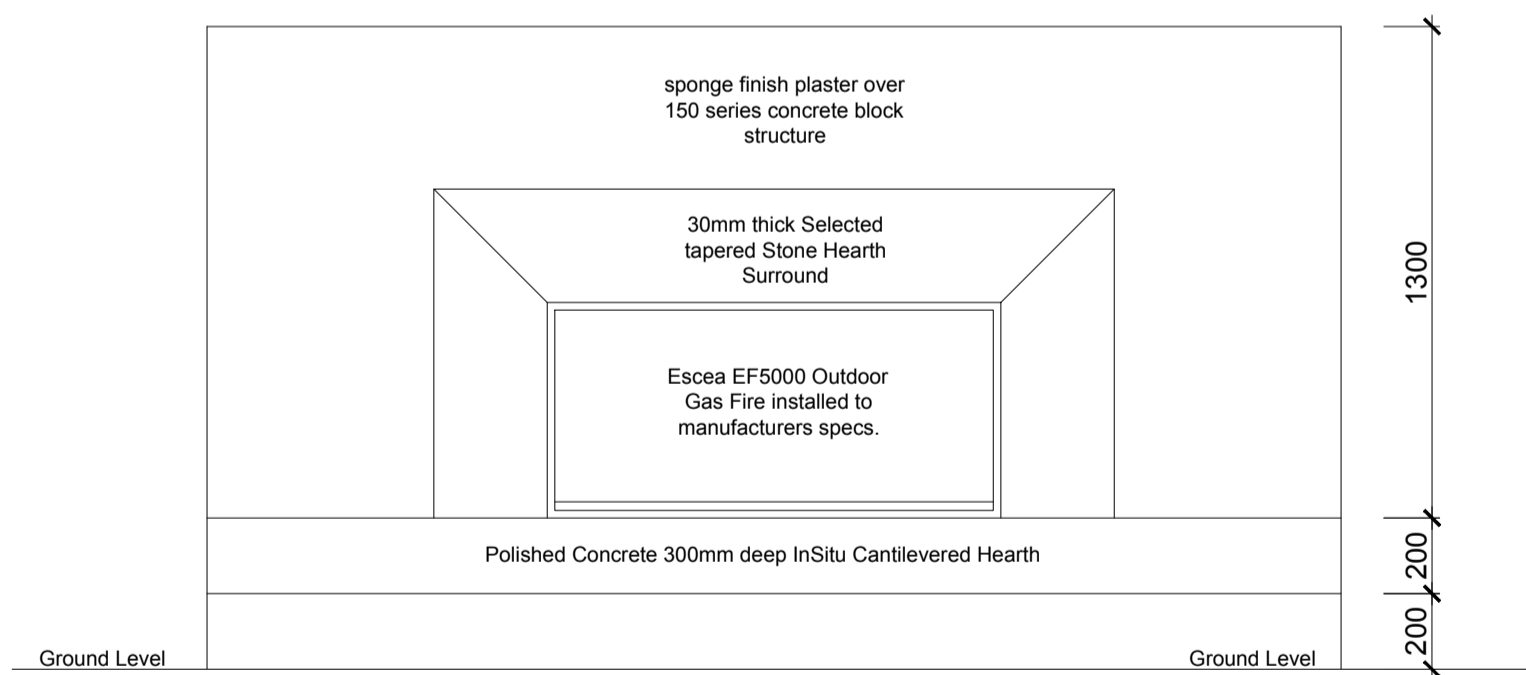

**Outdoor Fire Elevation**  
scale 1:20

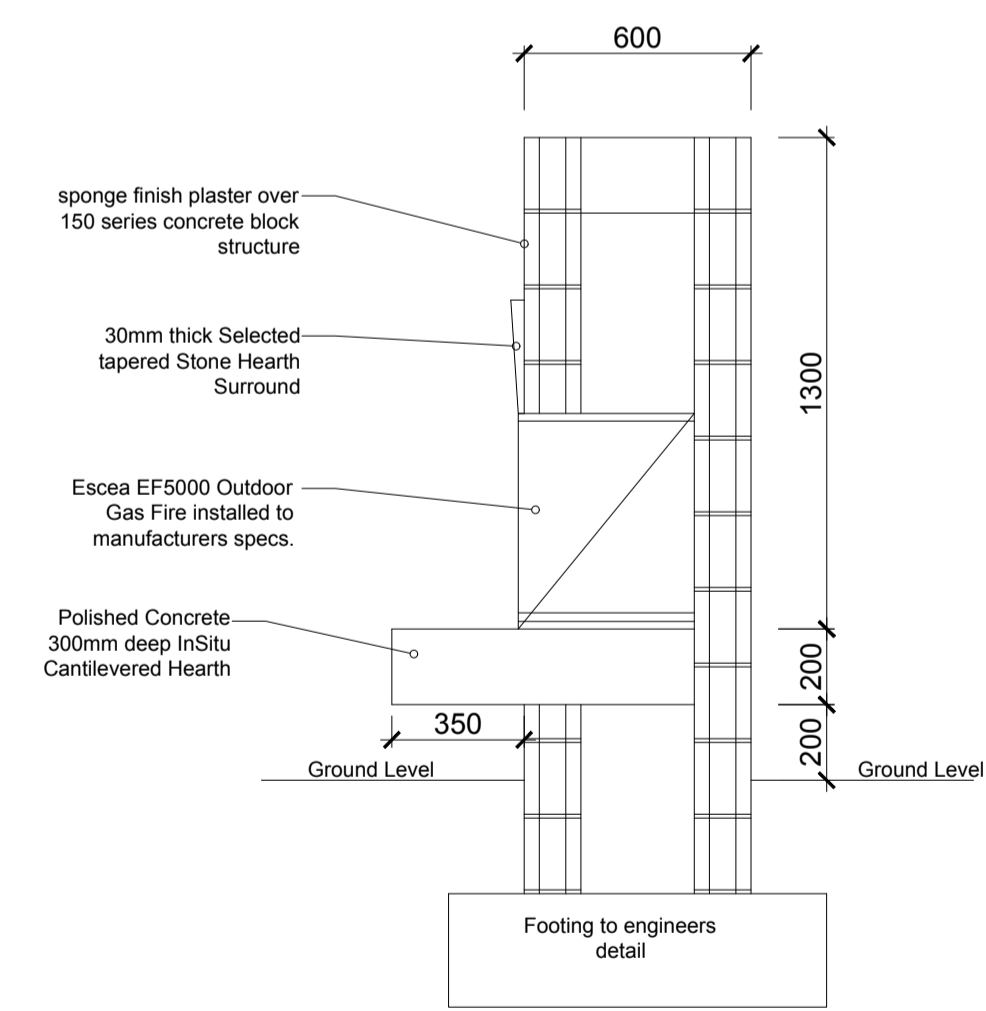

**Outdoor Fire Section**  
scale 1:20

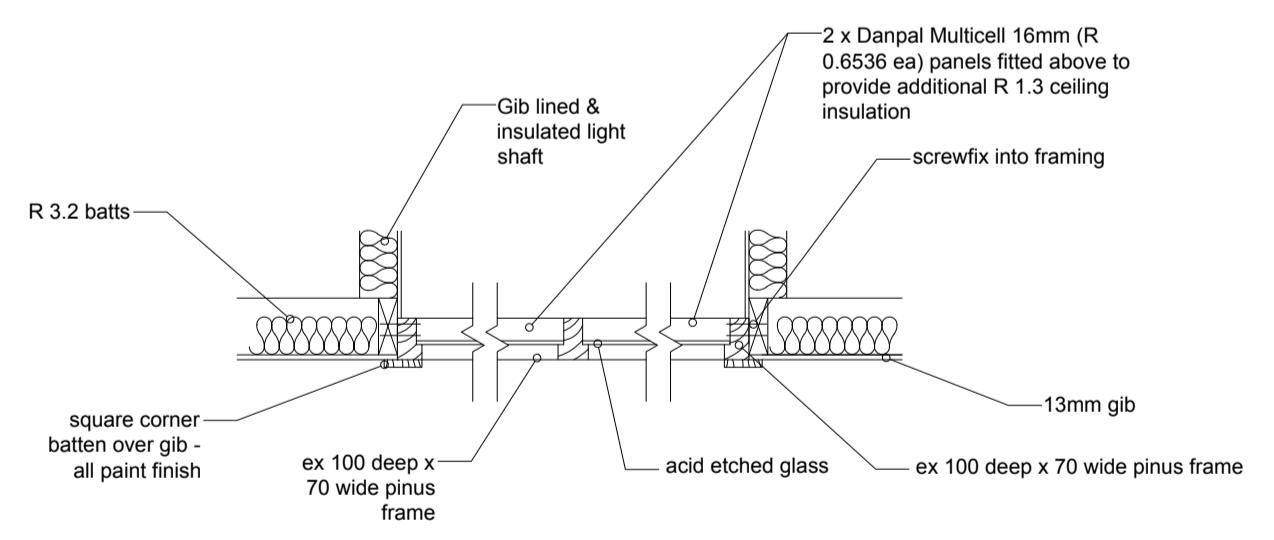

**Rooflight Detail - Apartment 2**  
scale 1:20

Revisions	General notes

NOTE:  
**STAGE 2  
CONSENT**

59 ROSEBERRY AVE BIRKENHEAD AUCKLAND TEL (09)418 2432 FAX (09)419 5142  
**APARTMENT DEVELOPMENT**  
 81 SANSFIELD STREET, HERNE BAY

**DELAMARE ARCHITECTS**

Date DEC'17  
 Scale 1/20 @ A1  
 Drawing Reference: APARTMENT 2 FITTINGS  
 Job no: SAR  
 Dep no: 043  
 Revision: CADREF

USE SQUARE DIMENSIONS. DO NOT SCALE FROM DRAWING. ALL LEVELS AND DIMENSIONS TO BE CHECKED ON SITE. DRAWING TO BE READ IN CONJUNCTION WITH ALL RELEVANT DOCUMENTS. © THE COPYRIGHT OF THIS DRAWING IS THE PROPERTY OF DAVID DELAMARE.

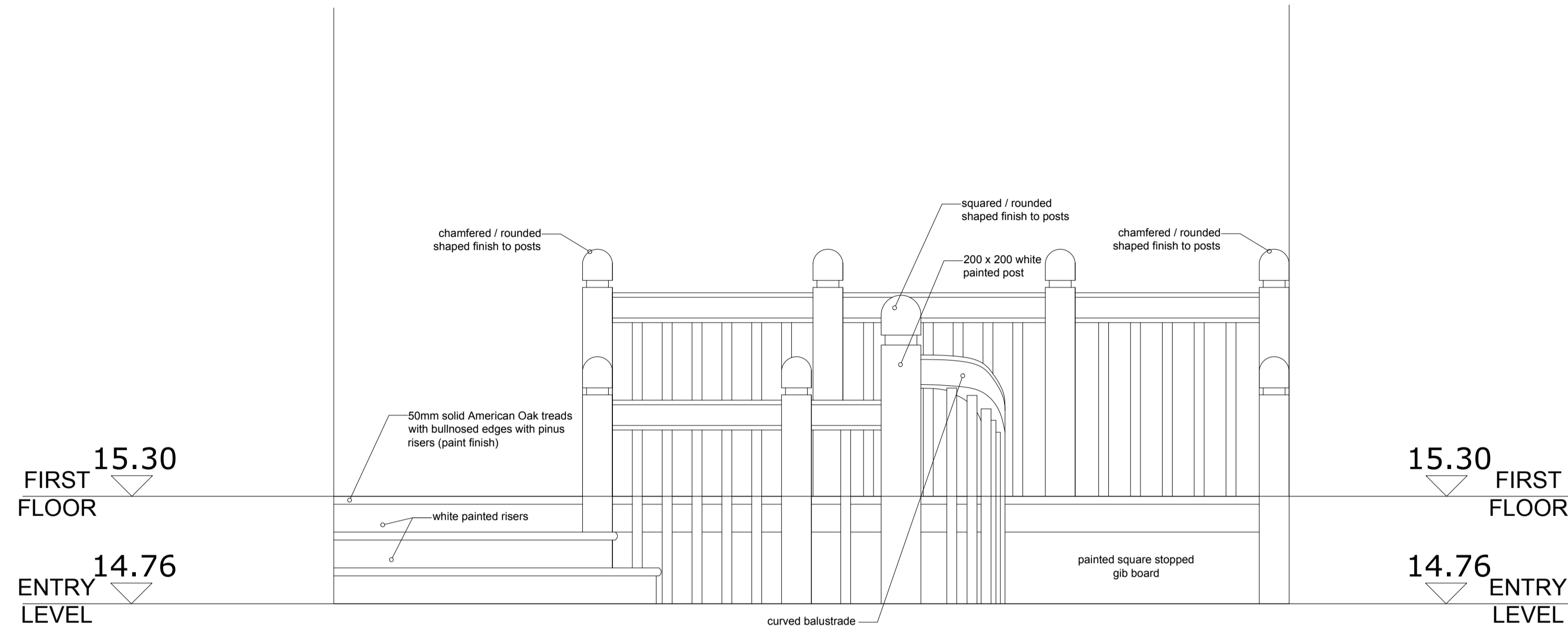

**Stair & Balustrade Detail**  
scale 1:20 Apartment 2

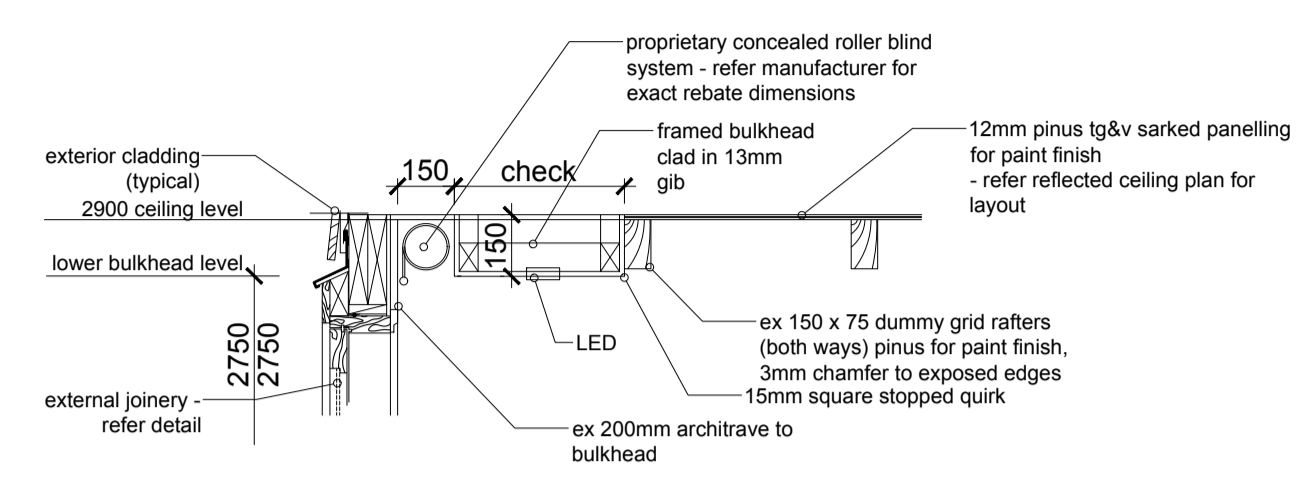

**Interior Ceiling Bulkhead / Panelling detail (typical)**  
scale 1:20

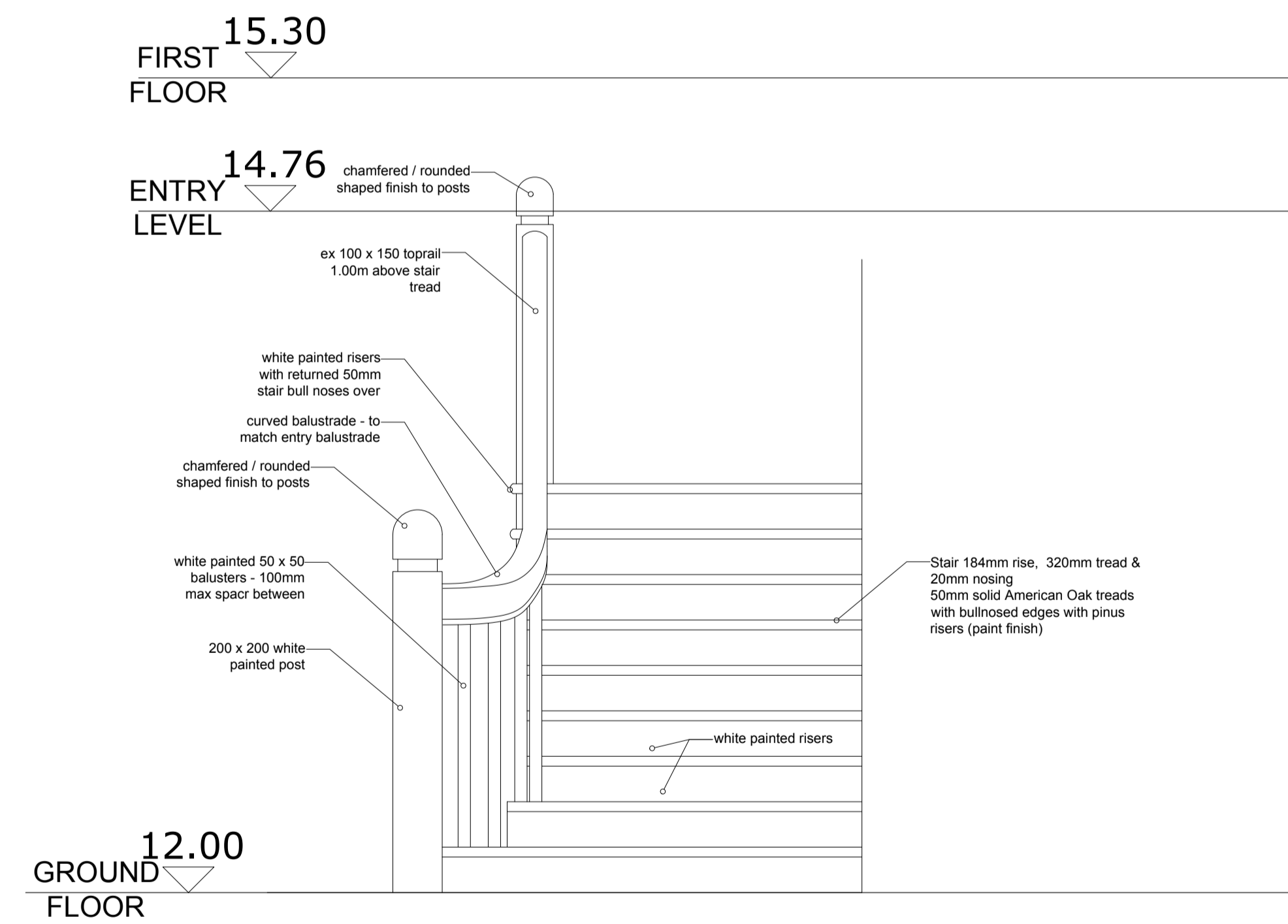

**Stair & Balustrade Detail**  
scale 1:20 Apartment 2

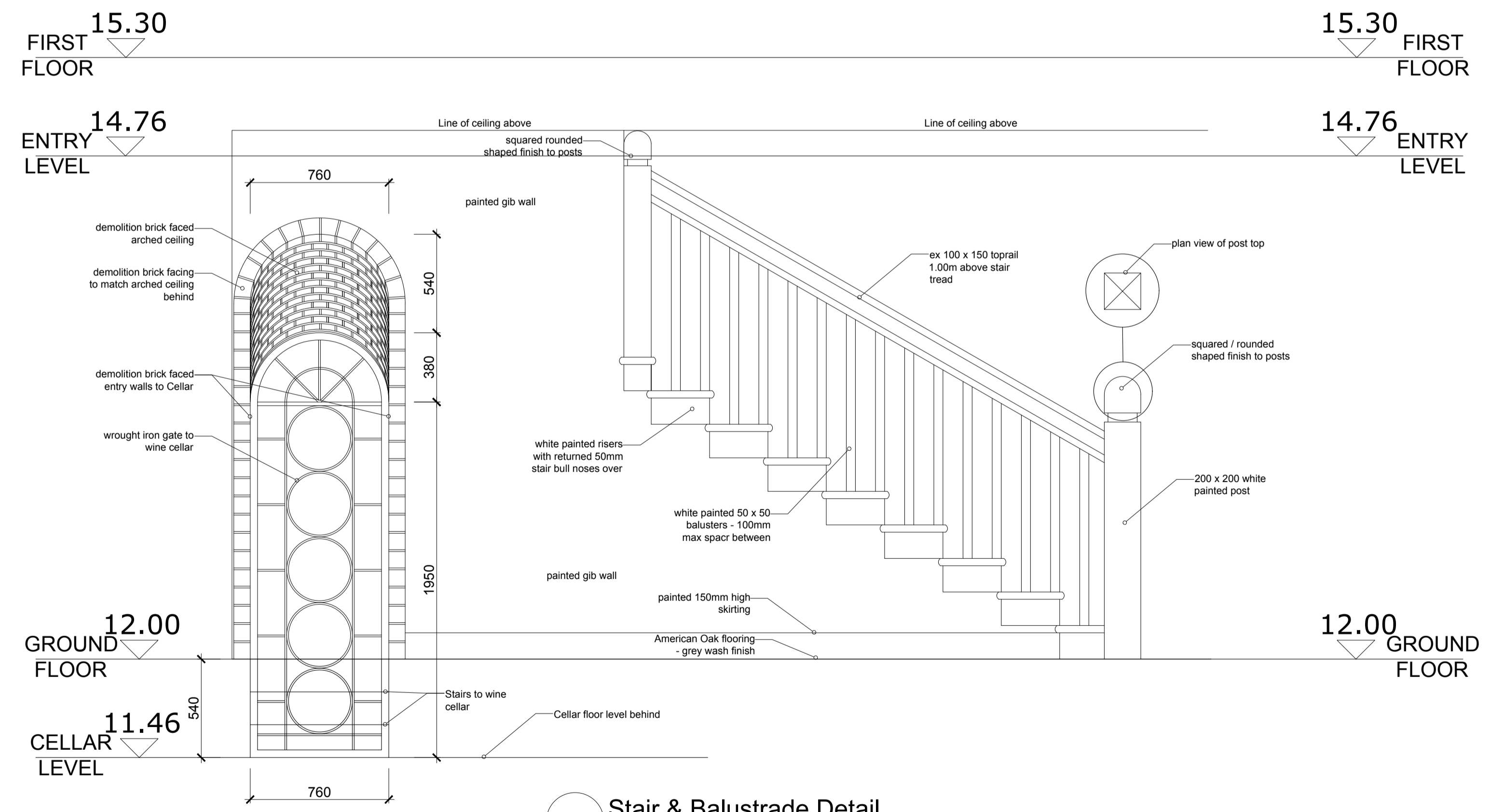

**Stair & Balustrade Detail**  
scale 1:20 Apartment 2

Revisions	General notes

NOTE:  
**STAGE 2  
CONSENT**

59 ROSEBERRY AVE BIRKENHEAD AUCKLAND TEL (09)418 2432 FAX (09)419 5142  
 APARTMENT DEVELOPMENT  
 81 SARSFIELD STREET, HERNE BAY

**DELAMARE ARCHITECTS**

Date DEC'17  
 Scale 1/20 @ A1  
 Drawing Reference  
 APARTMENT 2  
 STAIRS  
 Job no SAR  
 Draw no 044  
 revision  
 Cad ref SAR  
 CADREF

USE SQUARE DIMENSIONS. DO NOT SCALE FROM DRAWING. ALL LEVELS AND DIMENSIONS TO BE CHECKED ON SITE. DRAWING TO BE READ IN CONJUNCTION WITH ALL RELEVANT DOCUMENTS. ©THE COPYRIGHT OF THIS DRAWING IS THE PROPERTY OF DAVID DELAMARE.

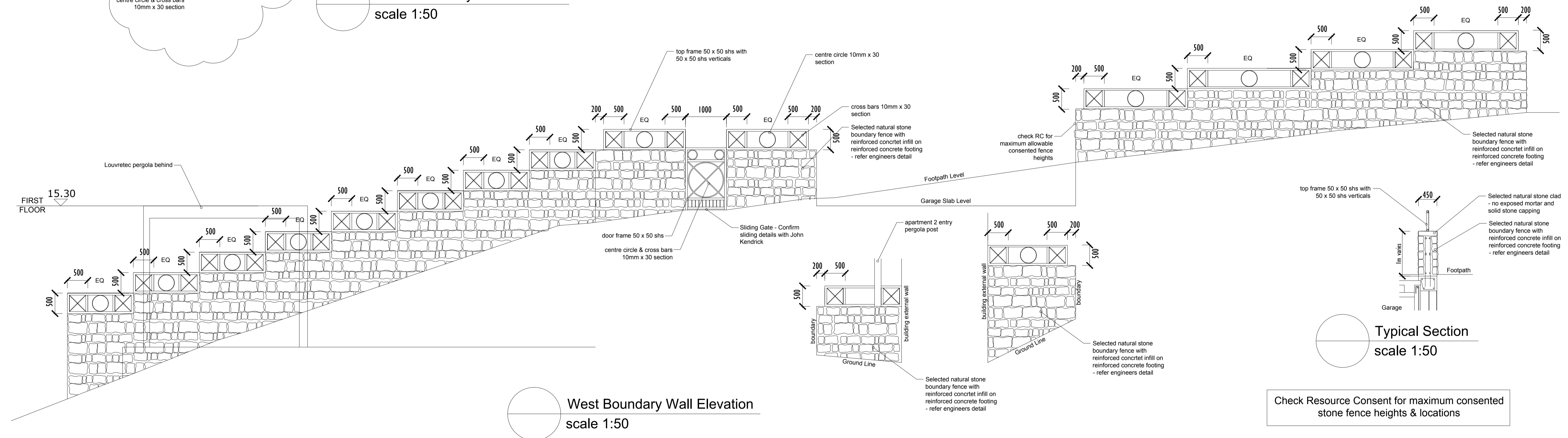
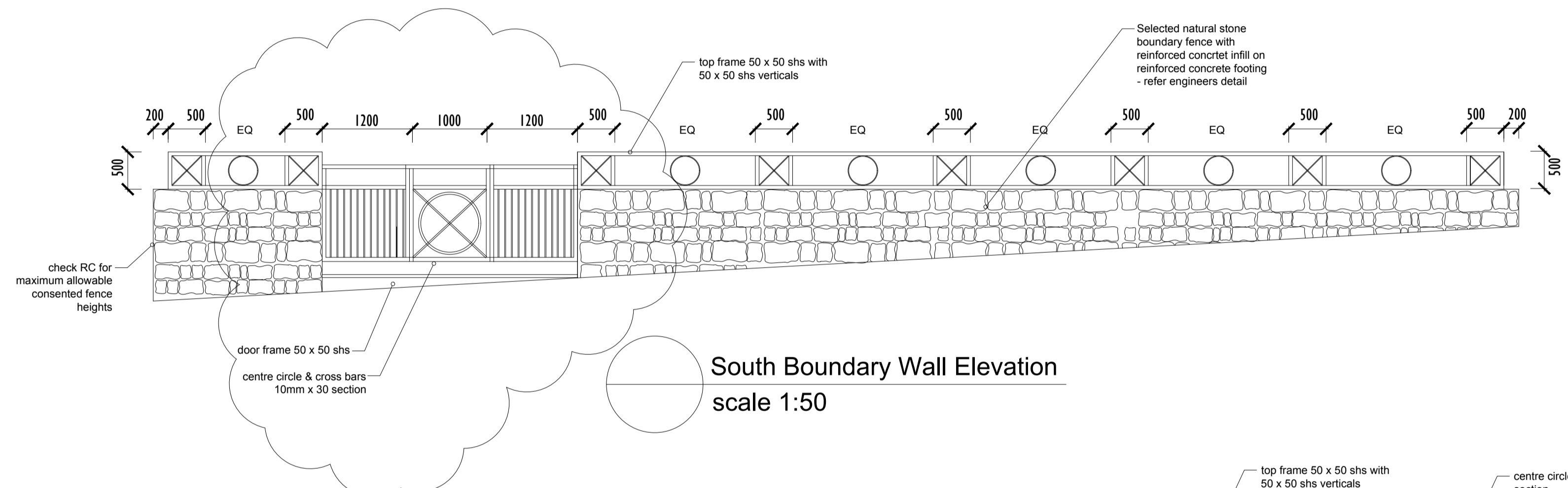
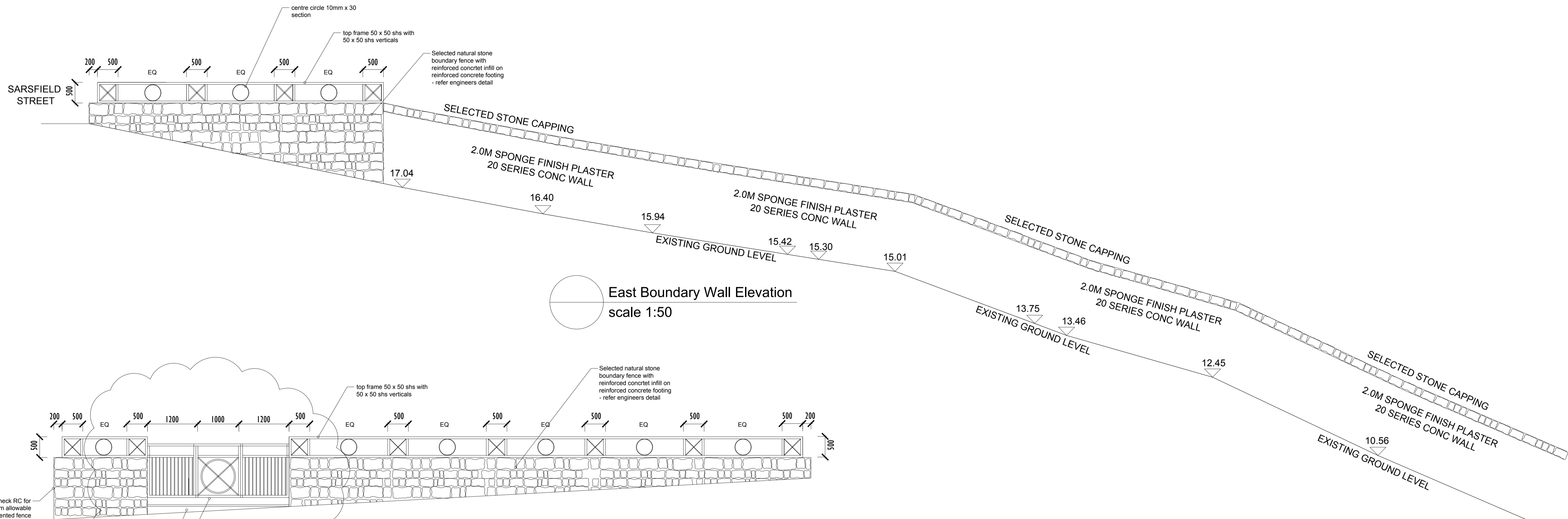

Check Resource Consent for maximum consented stone fence heights & locations

Revisions	General notes

NOTE:  
**AMENDMENT**  
**09/18**

59 ROSEBERRY AVE, BIRKENHEAD, AUCKLAND, TEL: (09) 418 2432, FAX: (09) 419 5142  
**APARTMENT DEVELOPMENT**  
 81 Sarsfield Street, Herne Bay

**DELAMARE ARCHITECTS**

BOUNDARY FENCING Drawing Reference: SAR 045 Date: DEC'17 Scale: 1/50 @ A1  
 USE FIGURED DIMENSIONS. DO NOT SCALE FROM DRAWING. ALL LEVELS AND DIMENSIONS TO BE CHECKED ON SITE. DRAWING TO BE READ IN CONJUNCTION WITH ALL RELEVANT DOCUMENTS. © THE COPYRIGHT OF THIS DRAWING IS THE PROPERTY OF DAVID DELAMARE.

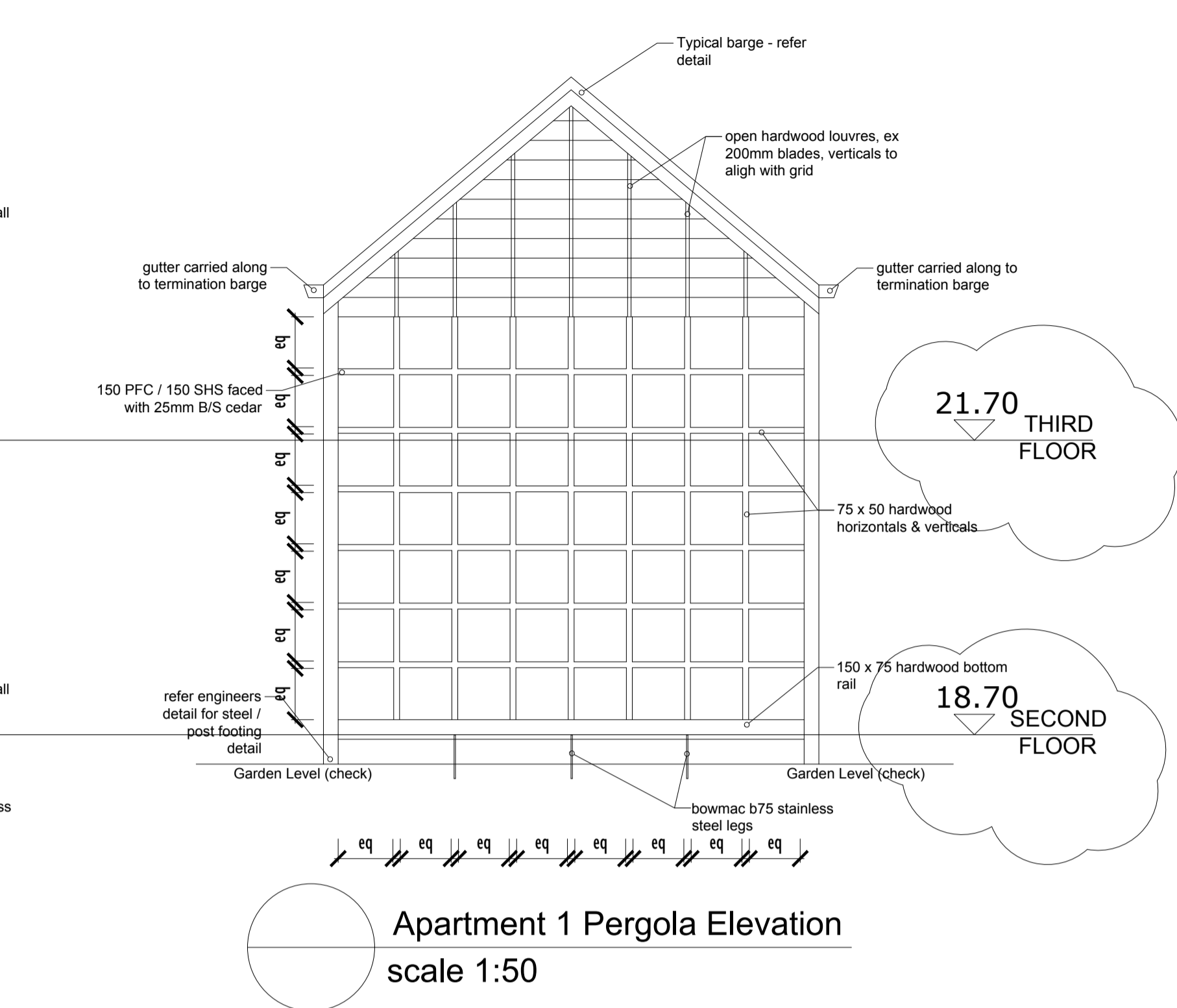
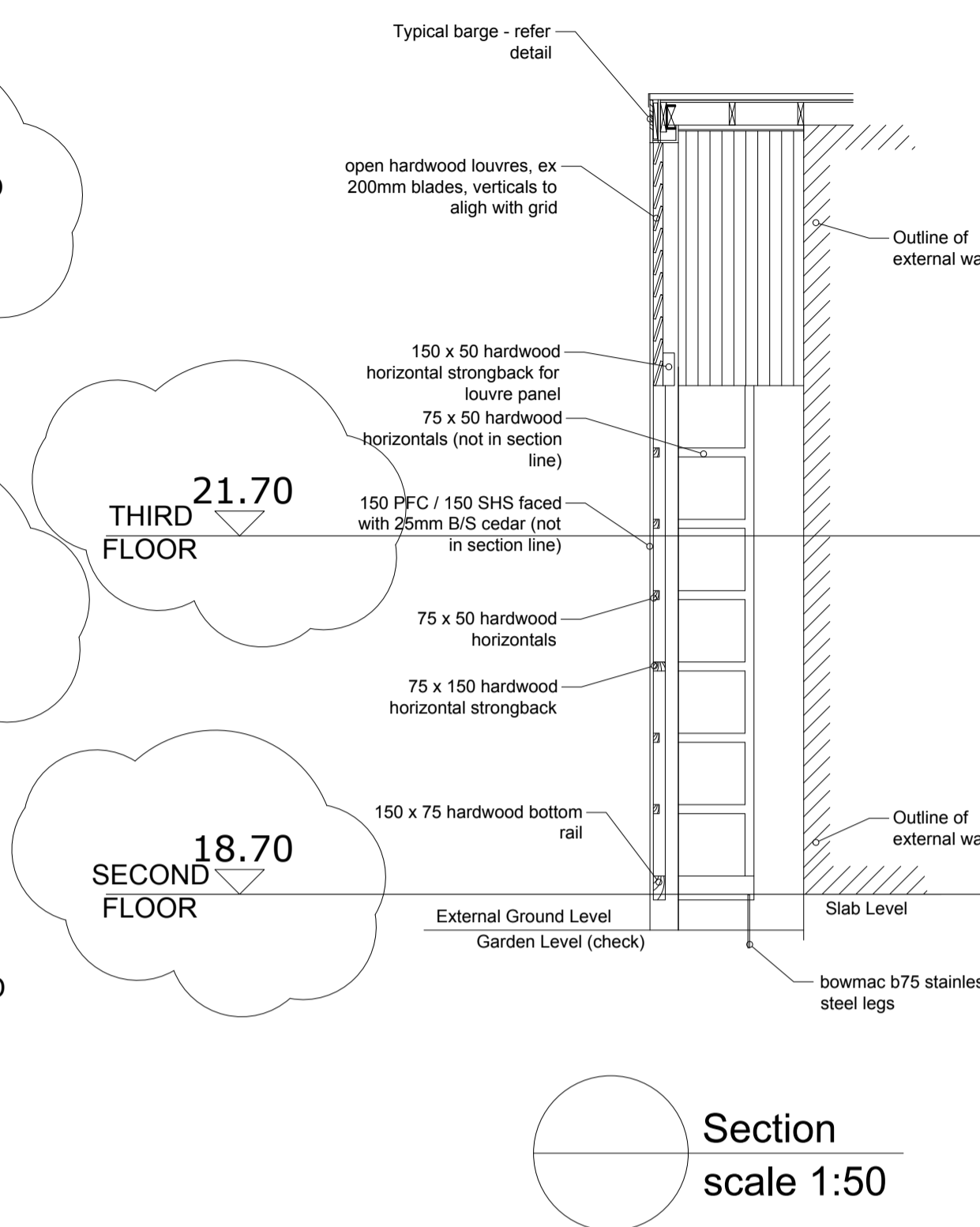
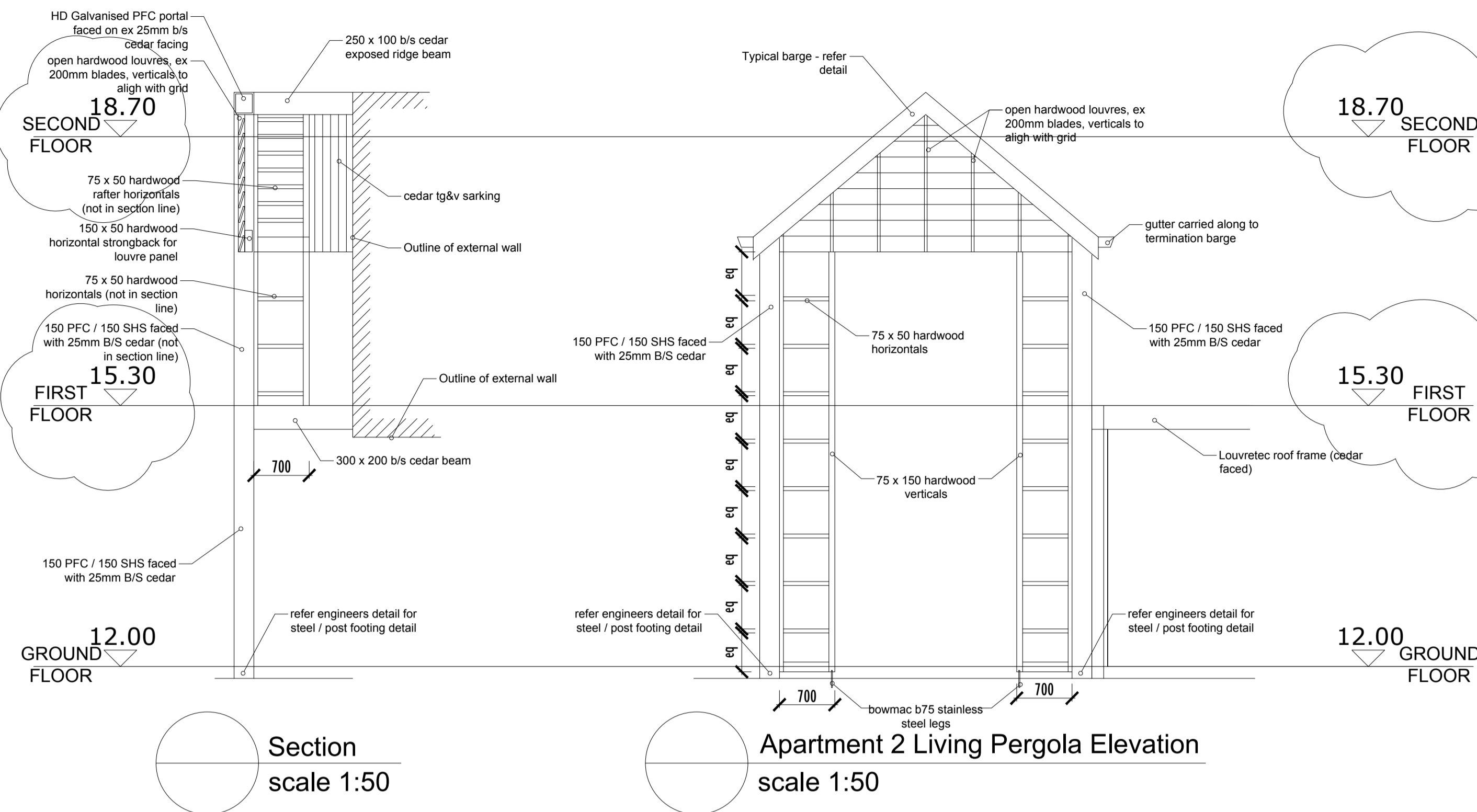

All concealed steelwork HD galvanised and all exposed fittings stainless steel.  
Grid infill timber all Australian or Brazilian hardwood in long lengths - certified durability

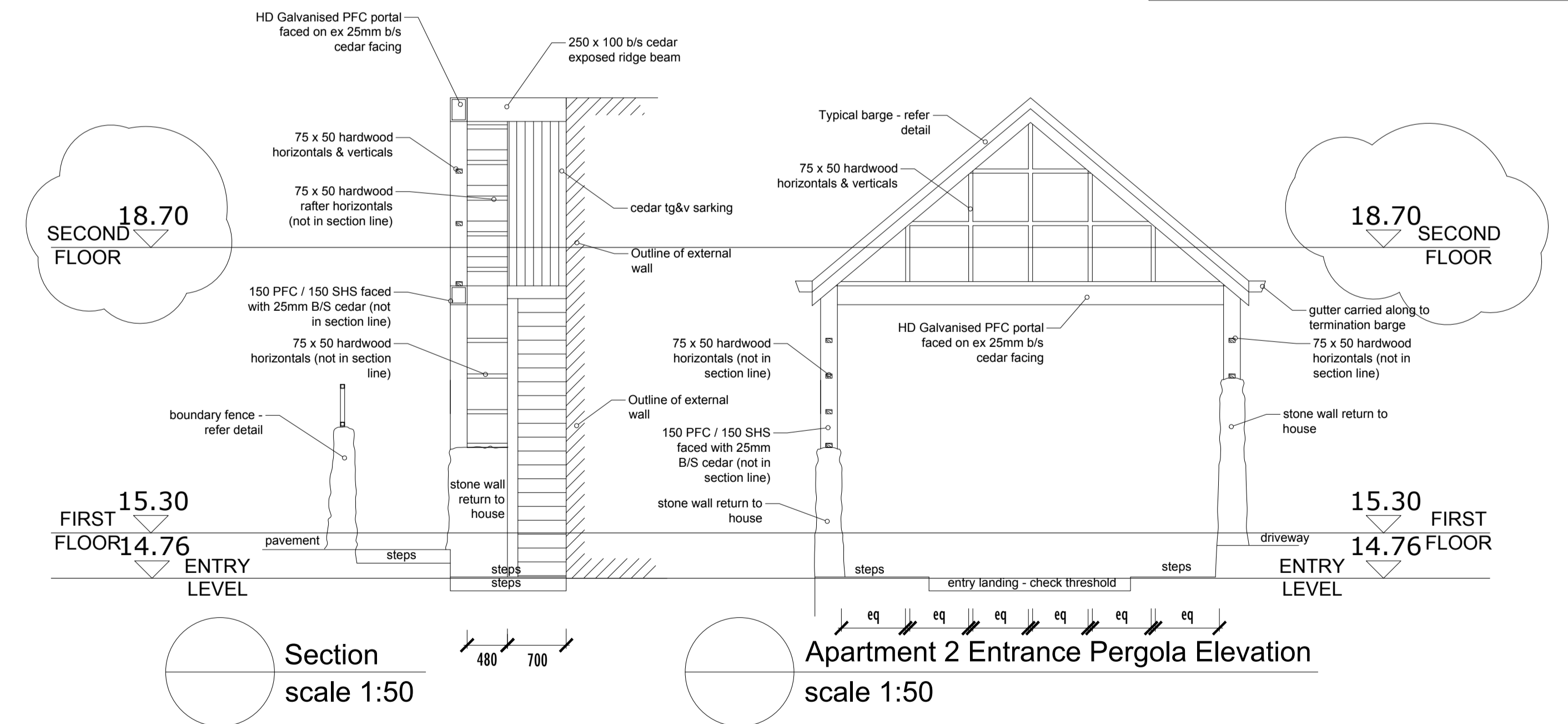

Revisions	General notes

NOTE:  
**AMENDMENT**  
**09/18**

59 ROSEBERRY AVE, BIRKENHEAD, AUCKLAND. TEL: (09) 418 2432. FAX: (09) 419 5142  
**APARTMENT DEVELOPMENT**  
 81 SARSFIELD STREET, HERNE BAY

**DELAMARE ARCHITECTS**

ENTRY PERGOLAS Drawing Reference: SAR 046 Date: DEC'17 Scale: 1/50 @ A1  
 Drawing Reference: SAR 046 Date: DEC'17 Scale: 1/50 @ A1  
 Drawing Reference: SAR 046 Date: DEC'17 Scale: 1/50 @ A1

USE FIGURED DIMENSIONS. DO NOT SCALE FROM DRAWING. ALL LEVELS AND DIMENSIONS TO BE CHECKED ON SITE. DRAWING TO BE READ IN CONJUNCTION WITH ALL RELEVANT DOCUMENTS. © THE COPYRIGHT OF THIS DRAWING IS THE PROPERTY OF DELAMARE ARCHITECTS.

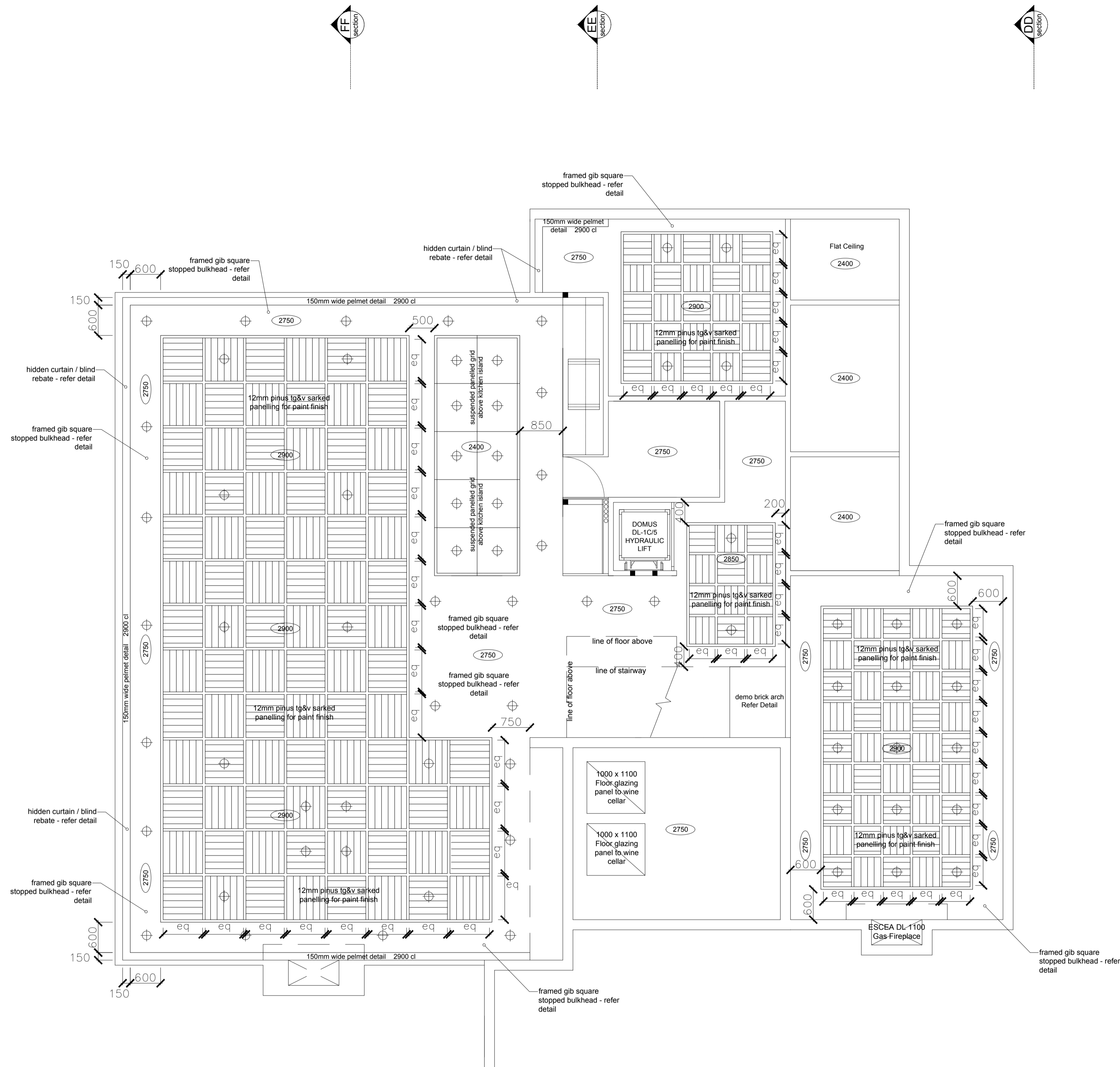

Ground Floor Reflected Ceiling Plan  
scale 1:50

Revisions	General notes

NOTE:  
**STAGE 2  
CONSENT**

59 ROSEBERRY AVE BIRKENHEAD AUCKLAND TEL (09)418 2432 FAX (09)419 5142  
 APARTMENT DEVELOPMENT  
 81 Sarsfield Street, Herne Bay

REFLECTED CEILING PLAN GD FLOOR

Drawing Reference  
 Job no: SAR  
 Draw no: 047  
 revision

Date: DEC'17  
 Scale: 1/50 @ A1  
 Cod ref: SAR  
 CADREF

**DELAMARE ARCHITECTS**

USE DIMENSIONS: DO NOT SCALE FROM DRAWING. ALL LEVELS AND DIMENSIONS TO BE CHECKED ON SITE. DRAWING TO BE READ IN CONJUNCTION WITH ALL RELEVANT DOCUMENTS. © THE COPYRIGHT OF THIS DRAWING IS THE PROPERTY OF DAVID DELAMARE.

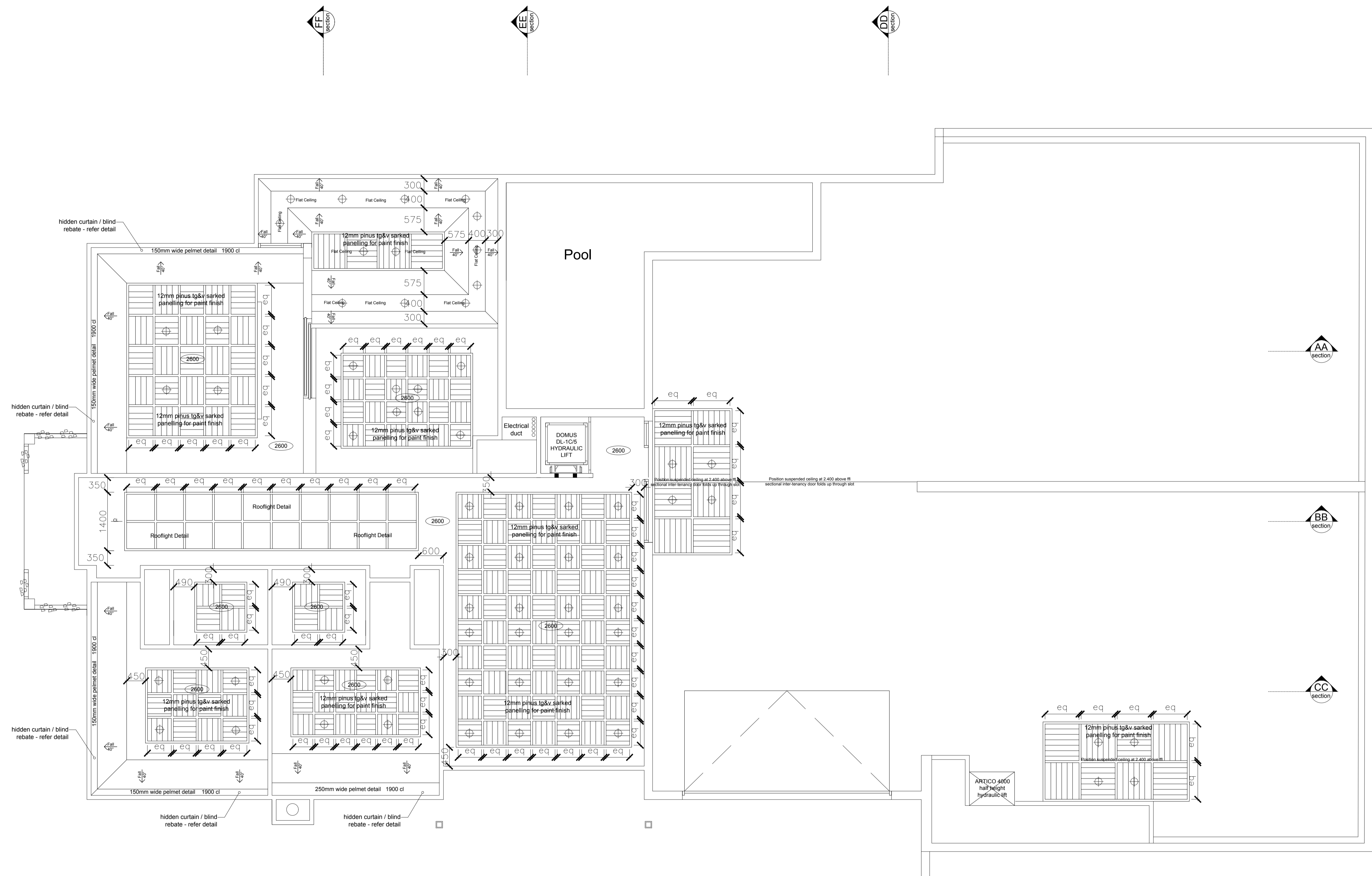

First Floor Reflected Ceiling Plan  
scale 1:50

Revisions	General notes

Revisions	General notes

Revisions	General notes

NOTE:

**STAGE 2  
CONSENT**

59 ROSEBERRY AVE BIRKENHEAD AUCKLAND TEL (09)418 2432 FAX (09)419 5142  
APARTMENT DEVELOPMENT  
81 SARSFIELD STREET, HERNE BAY

REFLECTED CEILING  
PLAN 1ST FLOOR

Drawing Reference  
job no: SAR  
dep no: 048  
revision

Date: DEC'17  
Scale: 1/50 @ A1  
Cod ref: SAR  
CADREF

**DELAMARE  
ARCHITECTS**

USE POURED DIMENSIONS. DO NOT SCALE FROM DRAWING.  
ALL LEVELS AND DIMENSIONS TO BE CHECKED ON SITE.  
DRAWING TO BE READ IN CONJUNCTION WITH ALL  
RELEVANT DOCUMENTS.  
© THE COPYRIGHT OF THIS DRAWING IS THE PROPERTY  
OF DAVID DELAMARE



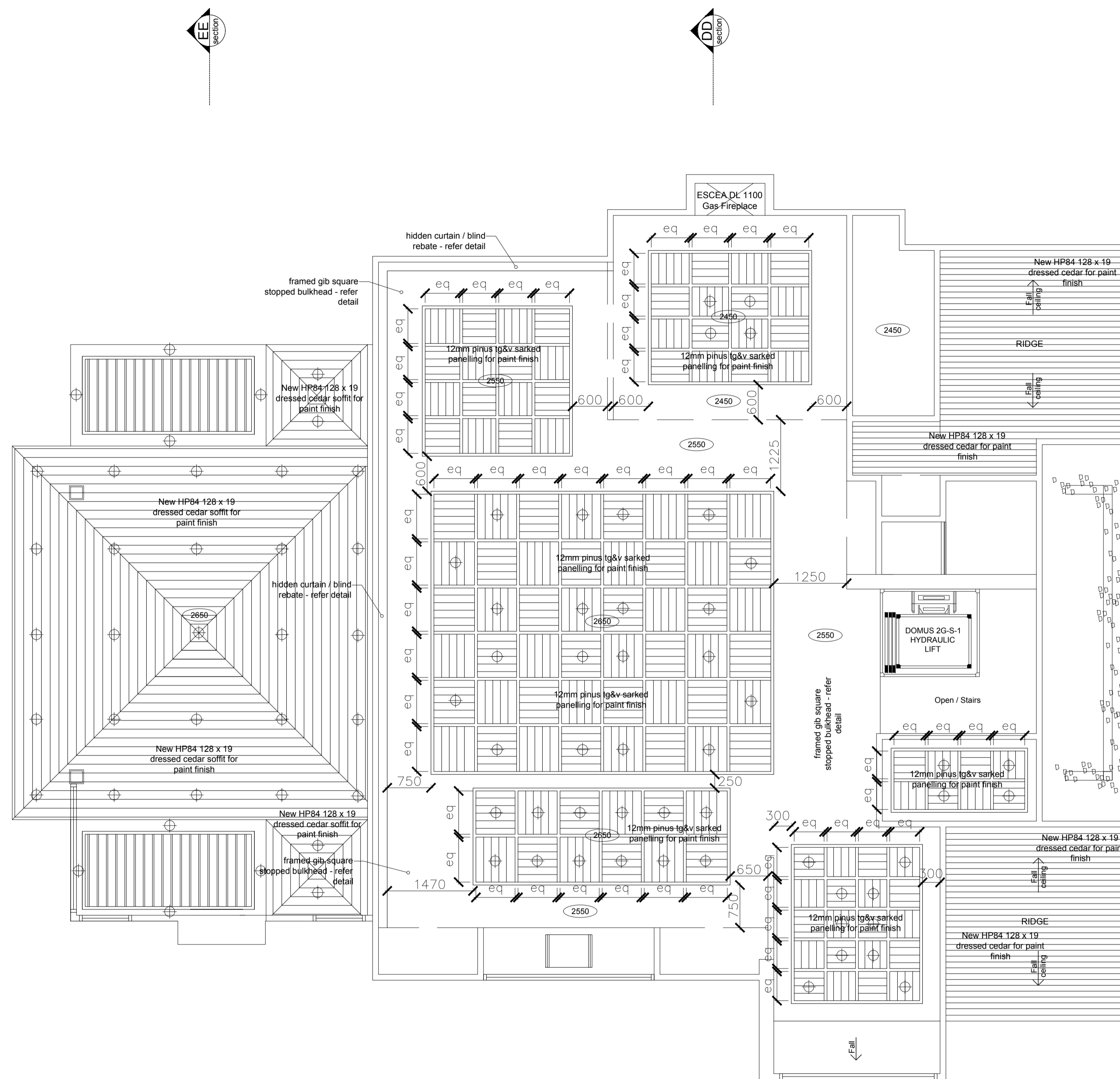

Second Floor Reflected Ceiling Plan  
scale 1:50

Revisions	General notes

NOTE:  
**STAGE 2  
CONSENT**

59 ROSEBERRY AVE, BIRKENHEAD, AUCKLAND. TEL (09)418 2432 FAX (09)419 5142  
 APARTMENT DEVELOPMENT  
 81 SANSFIELD STREET, HERNE BAY

REFLECTED CEILING PLAN 2ND FLOOR

Drawing Reference: SAR 049

Date: DEC'17  
 Scale: 1/50 @ A1  
 Cad ref: SAR  
 CADREF

**DELAMARE ARCHITECTS**

USE DIMENSIONS: DO NOT SCALE FROM DRAWING. ALL LEVELS AND DIMENSIONS TO BE CHECKED ON SITE. DRAWING TO BE READ IN CONJUNCTION WITH ALL RELEVANT DOCUMENTS. © THE COPYRIGHT OF THIS DRAWING IS THE PROPERTY OF DAVID DELAMARE.

AA section

BB section

CC section

EE section

DD section

AA section

BB section

CC section

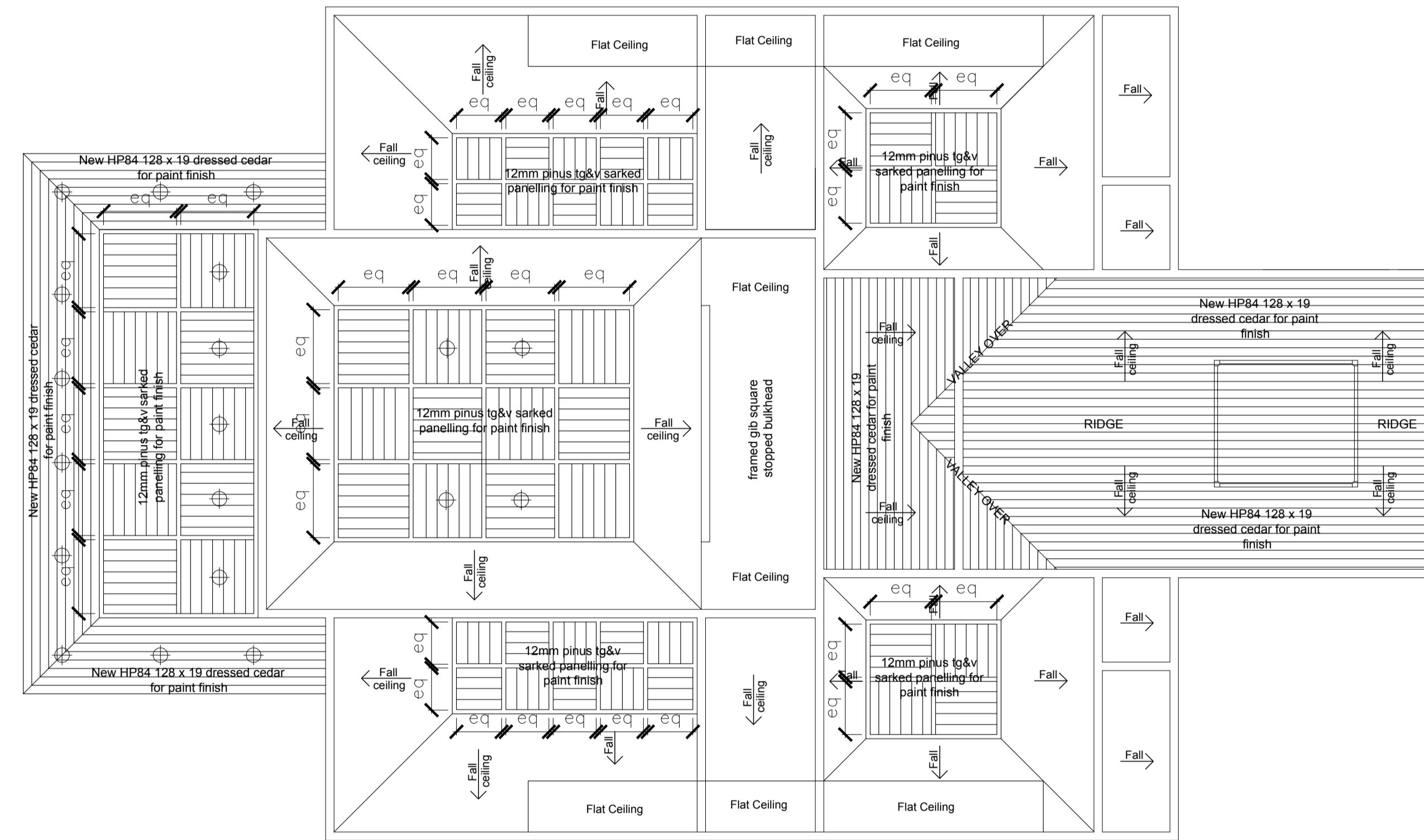

Third Floor Reflected Ceiling Plan  
scale 1:50

Revisions	General notes

NOTE:

**STAGE 2  
CONSENT**

59 ROSEBERRY AVE BIRKENHEAD AUCKLAND TEL (09)418 2432 FAX (09)419 5142  
 APARTMENT DEVELOPMENT  
 81 SARSFIELD STREET, HERNE BAY

REFLECTED CEILING Drawing Reference  
 PLAN 3RD FLOOR SAR 050

Date DEC'17  
 Scale 1/50 @ A1  
 Cod ref SAR  
 CADREF

**DELAMARE ARCHITECTS**

USE DIMENSIONS: DO NOT SCALE FROM DRAWING. ALL LEVELS AND DIMENSIONS TO BE CHECKED ON SITE. DRAWING TO BE READ IN CONJUNCTION WITH ALL RELEVANT DOCUMENTS. © THE COPYRIGHT OF THIS DRAWING IS THE PROPERTY OF DAVID DELAMARE.

Note : Security - refer owner  
 : Sound, T.V., Telephone - refer owner  
 : Airconditioning - Refer Owner

Key - Electrical Gas Plumbing

- ⊕ recessed LED 12v
- ⊕-W selected LED wall @2000mm above FFL
- ⊕-b Exterior/Interior LED wall lamp @ 300mm above FFL
- ⊕-b Exterior beam mounted LED
- meter board
- sub board
- LED strip light
- ⊕-e recessed LED 12v eyeball
- ⊕ double power point
- ⊕ telephone outlet, owner to confirm
- ⊕ TV outlet
- ⊕-ww recessed 12 volt LED wall washer
- ⊕-sa smoke alarm

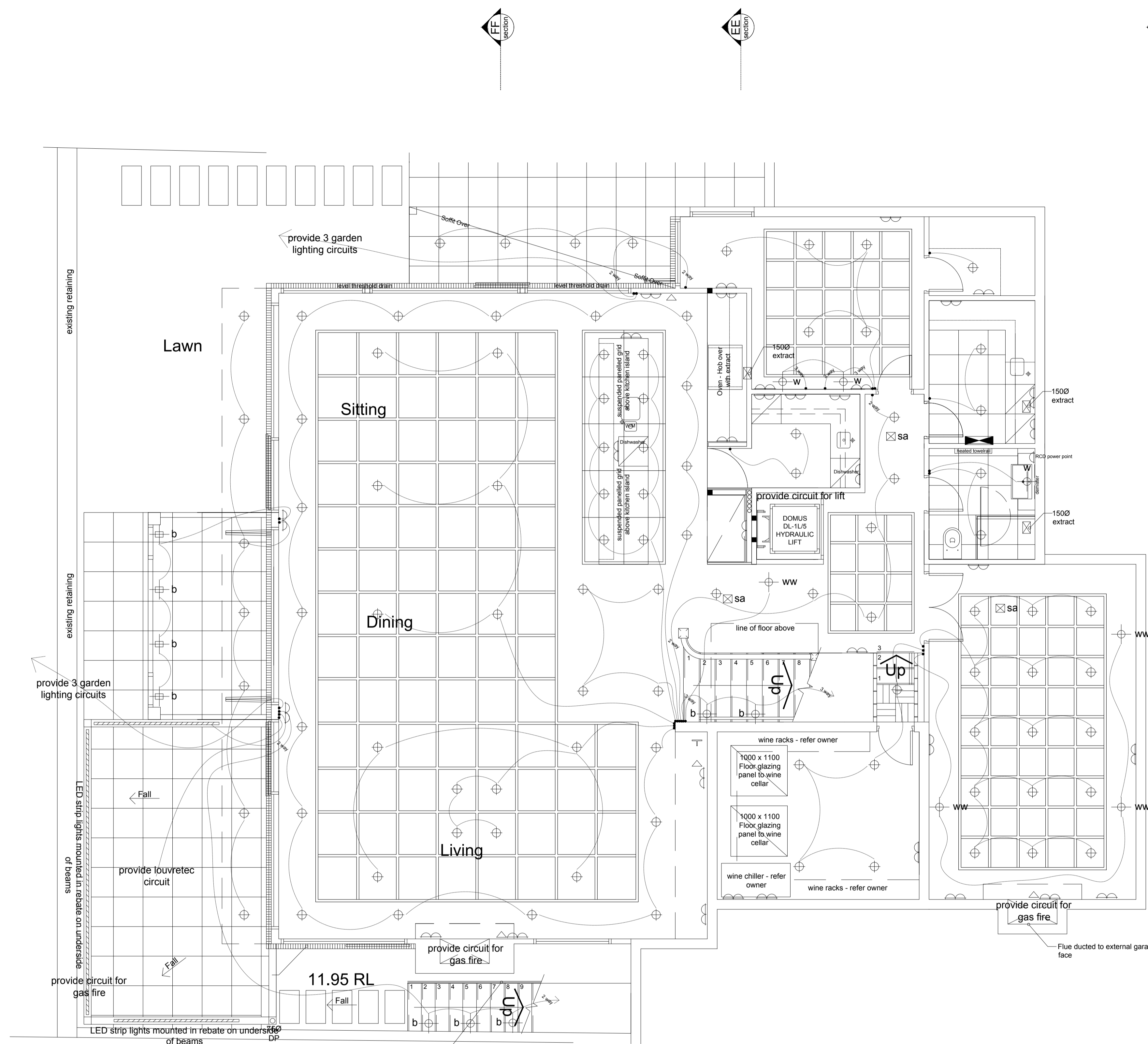

Ground Floor Electrical  
 scale 1:50

KEY  
 ⊕-sa smoke alarm

Revisions	General notes

NOTE:  
**STAGE 2  
 CONSENT**

59 ROSEBERRY AVE BIRKENHEAD AUCKLAND TEL (09)418 2432 FAX (09)419 5142  
 APARTMENT DEVELOPMENT  
 81 SANSFIELD STREET, HERNE BAY

**DELAMARE ARCHITECTS**

ELECTRICAL PLAN Drawing Reference Date DEC'17  
 GROUND FLOOR SAR 051 Scale 1:50 @ A1  
 Job no. revision Cod ref SAR  
 © THE COPYRIGHT OF THIS DRAWING IS THE PROPERTY OF DAVID DELAMARE

**Note : Security - refer owner**  
**: Sound, T.V., Telephone - refer owner**  
**: Airconditioning - Refer Owner**

**Key - Electrical Gas Plumbing**

- ⊕ recessed LED 12v
- ⊕ w selected LED wall @2000mm above FFL
- ⊕ b Exterior/Interior LED wall lamp @ 300mm above FFL
- ⊕ b Exterior beam mounted LED
- ▬ meter board
- ▬ sub board
- ▬ LED strip light
- ⊕ e recessed LED 12v eyeball
- ⊕ double power point
- ⊕ telephone outlet, owner to confirm
- ⊕ TV outlet
- ⊕ WW recessed 12 volt LED wall washer
- ⊕ sa smoke alarm

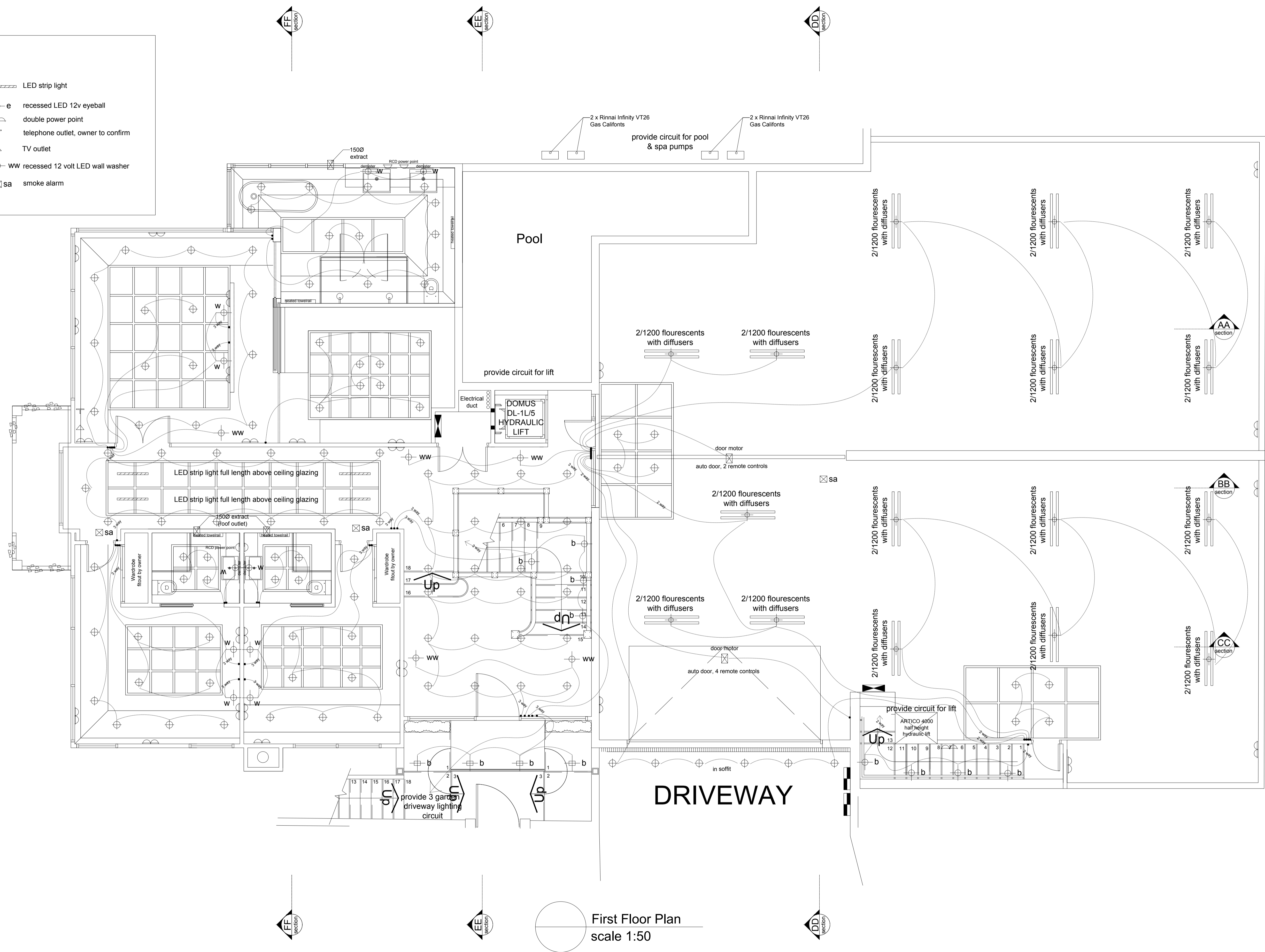

First Floor Plan  
 scale 1:50

Revisions	General notes

NOTE:  
**STAGE 2  
 CONSENT**

59 ROSEBERRY AVE BIRKENHEAD AUCKLAND TEL (09)418 2432 FAX (09)419 5142  
 APARTMENT DEVELOPMENT  
 81 SANSFIELD STREET, HERNE BAY

**DELAMARE ARCHITECTS**

ELECTRICAL PLAN Drawing Reference Date DEC'17  
 FIRST FLOOR job no: SAR 052 Scale 1/50 @ A1  
 revision: Cod ref SAR  
 CADREF

USE FIGURED DIMENSIONS. DO NOT SCALE FROM DRAWING. ALL LEVELS AND DIMENSIONS TO BE CHECKED ON SITE. DRAWING TO BE READ IN CONJUNCTION WITH ALL RELEVANT DOCUMENTS. ©THE CONTENT OF THIS DRAWING IS THE PROPERTY OF DAVID DELAMARE.

**Key - Electrical Gas Plumbing**

- ⊕ recessed LED 12v
- ⊕-w selected LED wall @2000mm above FFL
- ⊕-b Exterior/Interior LED wall lamp @ 300mm above FFL
- ⊕-b Exterior beam mounted LED
- ▬ meter board
- ▬ sub board
- ▬ LED strip light
- ⊕-e recessed LED 12v eyeball
- ⌒ double power point
- ⌒ telephone outlet, owner to confirm
- △ TV outlet
- ⊕-ww recessed 12 volt LED wall washer
- ⊗-sa smoke alarm

**Note : Security - refer owner  
: Sound, T.V., Telephone - refer owner  
: Airconditioning - Refer Owner**

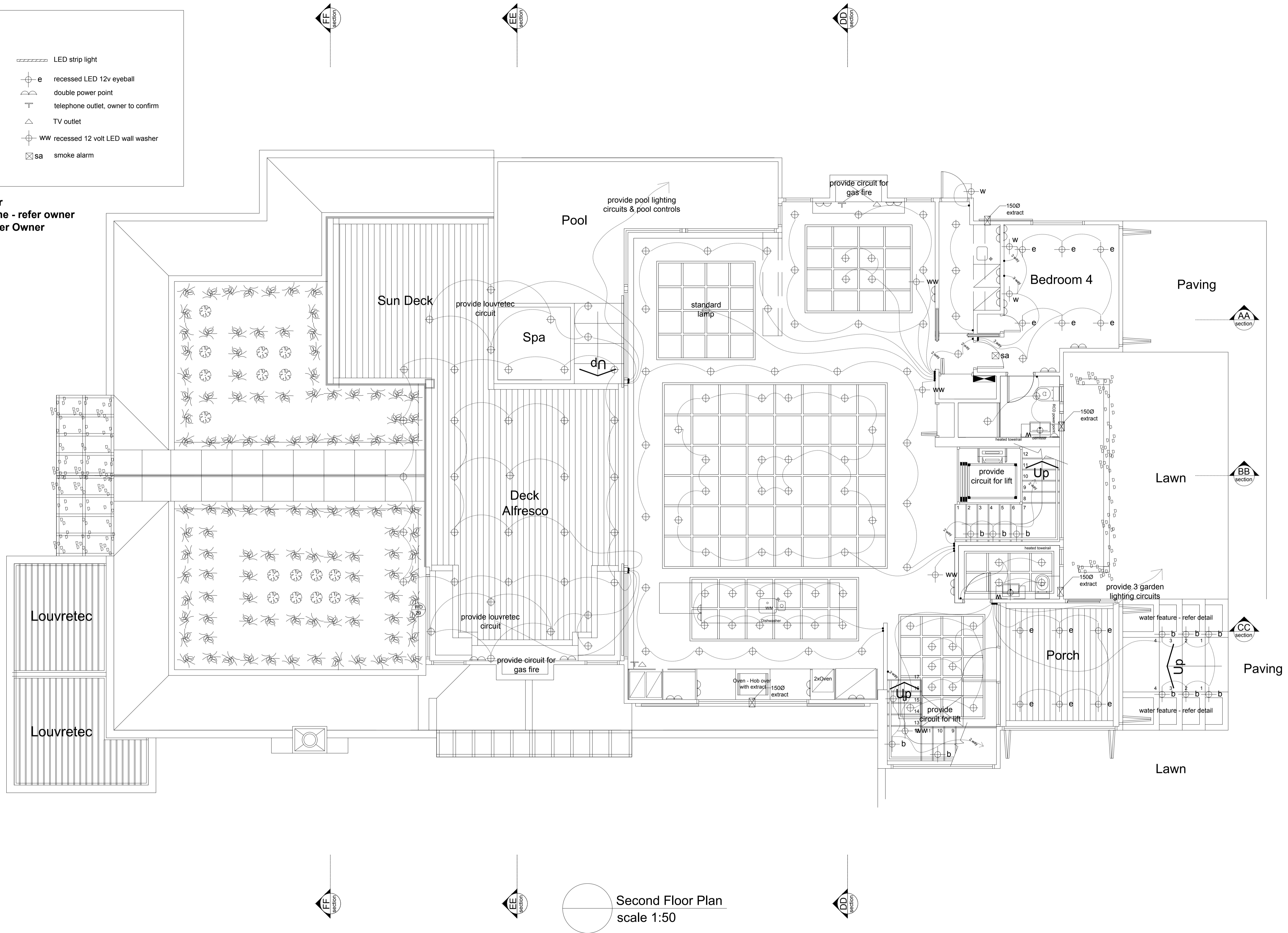

Second Floor Plan  
scale 1:50

Revisions	General notes

NOTE:  
**STAGE 2  
CONSENT**

59 ROSEBERRY AVE BIRKENHEAD AUCKLAND TEL (09)418 2432 FAX (09)419 5142  
 APARTMENT DEVELOPMENT  
 81 SANSFIELD STREET, HERNE BAY

**DELAMARE ARCHITECTS**

ELECTRICAL PLAN Drawing Reference Date DEC'17  
 SECOND FLOOR Job no: SAR 053 Scale 1/50 @ A1  
 Cod ref SAR revision  
 CADREF

USE DIMENSIONS: DO NOT SCALE FROM DRAWING. ALL LEVELS AND DIMENSIONS TO BE CHECKED ON SITE. DRAWING TO BE READ IN CONJUNCTION WITH ALL RELEVANT DOCUMENTS. ©THE COPYRIGHT OF THIS DRAWING IS THE PROPERTY OF DAVID DELAMARE.

**Key - Electrical Gas Plumbing**

- ⊕ recessed LED 12v
- ⊕ w selected LED wall @2000mm above FFL
- ⊕ b Exterior/Interior LED wall lamp @ 300mm above FFL
- ⊕ b Exterior beam mounted LED
- meter board
- sub board
- LED strip light
- ⊕ e recessed LED 12v eyeball
- double power point
- telephone outlet, owner to confirm
- TV outlet
- ⊕ ww recessed 12 volt LED wall washer
- ⊗ sa smoke alarm

**Note : Security - refer owner  
: Sound, T.V., Telephone - refer owner  
: Airconditioning - Refer Owner**

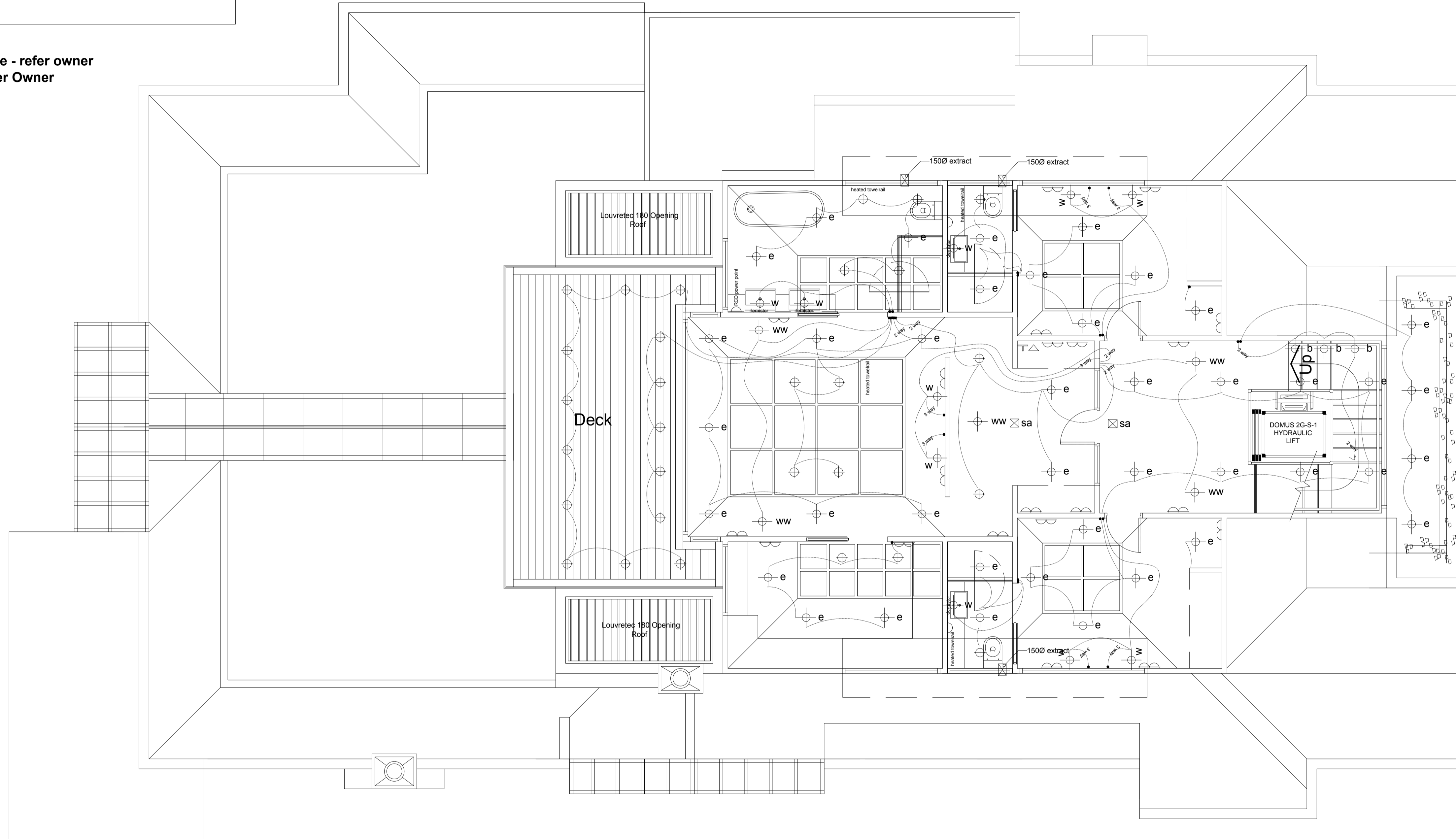

Third Floor Plan  
scale 1:50

Revisions	General notes

NOTE:  
**STAGE 2  
CONSENT**

59 ROSEBERRY AVE BIRKENHEAD AUCKLAND TEL (09)418 2432 FAX (09)419 5142  
**APARTMENT DEVELOPMENT**  
 81 SARSFIELD STREET, HERNE BAY

**DELAMARE ARCHITECTS**

ELECTRICAL PLAN Drawing Reference Date DEC'17  
 THIRD FLOOR SAR 054 Scale 1/50 @ A1  
 Cod ref SAR  
 © THE COPYRIGHT OF THIS DRAWING IS THE PROPERTY OF DAVID DELAMARE