

STOPDIGGING!

THE GROUND SCREW FOR SOLID FOUNDATIONS

80MM Ø SSI BRACKET WITH M12 TO GROUND SCREW PILE HEAD AND M12 THROUGH BEARER

REFER TO PLANS FOR JOIST SIZES

M12

REFER TO

GROUND SCREW SYSTEM

VARIES MIN 1500MM

750 STOP DIGGING GROUND SCREW AT LENGTH SELECTED TO TO ACHIEVE MINIMUM EMBEDMENT OF 1500MM

MIN 1500MM EMBEDMENT

DECKING DESIGN GUIDE

DATA SHEET & CONNECTIONS

TYPICAL HORIZONTAL

GROUND SCREW PILES TO BE SELECTED TO TO ACHIEVE MINIMUM EMBEDMENT OF 1500MM

STOPDIGGING!®



BEAM SCREW



Groundscrews provide a fast, clean and environmentally friendly way to create pile foundations for buildings and decks. This design guide for decking is for typical timber framing constructed to NZ3604. This guide will allow a quantity of piles to be determined based on timber sizes, and provides design loads required for load testing if necessary.

Our SGU Beam screw provides a standard pile foundation with a convenient fixing bracket for timber beams up to 95mm wide. This is available in a variety of lengths to enable installation in different types of ground conditions and topography.

Our larger SGC adapter screw, typically used for house foundations, is also suitable for commercial decking with higher load requirements, or to overcome very poor ground conditions.

Span tables from NZ3604 are included below to aid in specifying correct pile spacing and timber sizes.

NZS 3604 table 6.4 – Bearers – SG 8 for up to 2 kPa floor loads (see 6.12.2.1)

Maximum span of bearer continuous over 2 or more spans (m)	Loaded dimension* of bearer (m)	Bearer size (width x thickness) (mm x mm)
(b) 2.0 kPa floor load SG 8 and SG 8 (Wet) (wet in service)		
1.30	1.2	90 x 90
	2.3	140 x 70
	3.0	140 x 90
1.65	4.3	190 x 70
	0.7	90 x 90
	1.4	140 x 70
2.00	1.8	140 x 90
	2.7	190 x 70
	1.2	140 x 90
1.8	190 x 70	

NZS 3604 table 7.1(b) – Floor joists – SG 8 up to 2 kPa floor loads (see 7.1.1.1)

Floor joist size (mm x mm)	Maximum span* of joists at a maximum spacing (mm) of:		
	400 (m)	450 (m)	600 (m)
90 x 45	1.60	1.50	1.30
140 x 35	2.20	2.05	1.80
140 x 45	2.50	2.35	2.05
190 x 45	3.40	3.20	2.75
240 x 45	4.30	4.05	3.50
290 x 45	5.20	4.90	4.25

EXAMPLES OF USES



DECK DESIGN CHECKLIST

STOPDIGGING!

AMX
STRUCTURES

ADDRESS:

CLIENT:

This design checklist is for the purpose of designing StopDigging ground screw foundations for residential timber decks within the scope of NZS3604:2011.

1) CONFIRM MAXIMUM HEIGHT FROM GROUND LEVEL TO FINISHED DECK LEVEL:

MAXIMUM DECK HEIGHT ABOVE GROUND (mm)	MINIMUM GROUND SCREW EMBEDMENT (mm)	TICK
<500	500	
500 - 1000	800	

2) SIZE JOISTS AND SPECIFY MAXIMUM SPAN:

IN ACCORDANCE WITH NZS3604:2011 TABLE 7.1(B)

JOIST SIZE (SG8)	MAXIMUM SPAN OF JOISTS (400mm MAX SPACING):	TICK
90x45	1600	
140x45	2500	
190x45	3400	

3) SIZE BEARERS AND SPECIFY MAXIMUM SPAN:

IN ACCORDANCE WITH NZS3604:2011 TABLE 6.4(B)

GROUND SCREW SPACING (mm)	JOIST SIZE (SG8)	BEARER SIZE (SG8)	TICK
< 1300	90x45	2/90x45	
	140x45	2/140x45	
	190x45	2/190x45	
1300 - 1650	90x45	2/140x45	
	140x45	2/190x45	
	190x45	2/190x45	
1650 - 2000	90x45	2/140x45	
	140x45	2/190x45	
	190x45	2/190x45	

DECK DESIGN CHECKLIST



4) DETERMINE TESTING REQUIREMENTS FOR GROUND SCREWS:

LOAD TEST REQUIREMENTS (VERTICAL / LATERAL)			
BEARER SIZE	JOIST SIZE		
	90x45	140x45	190x45
2/90x45	8kN / 1kN	12kN / 2kN	16kN / 2kN
2/140x45	10kN / 1kN	14kN / 2kN	20kN / 3kN
2/190x45	12kN / 2kN	18kN / 2kN	24kN / 3kN

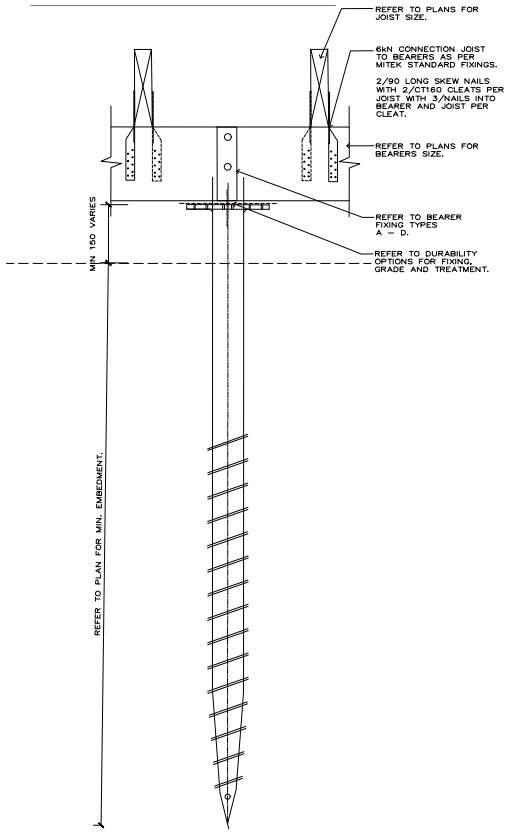

- GROUND SCREW NOTES:**
- GROUND SCREWS TO BE PROVIDED BY STOP DIGGING LTD.
 - SHALLOW SOIL TESTING IS REQUIRED TO DETERMINE THE SUITABILITY OF STOP DIGGING GROUND SCREW SYSTEM.
 - TENSILE, COMPRESSIVE AND LATERAL LOADING TESTS SHALL BE CARRIED OUT IN ACCORDANCE WITH STOP DIGGING GROUND SCREW SPECIFICATION.
 - ALL TIMBER TO BE RADIATA PINE, UNLESS NOTED OTHERWISE.
 - TOLERANCE FOR INSTALLATION. 15mm IN POSITION AND 1:500 OR 0.2% VERTICALLY.

TYPICAL GROUND SCREW DETAIL
SCALE 1:10

- FIXINGS A,B,C ARE SUITABLE FOR PILES PROVIDING LATERAL AND VERTICAL SUPPORT TO THE BUILDING.
- FIXING D IS SUITABLE FOR PILES PROVIDING ONLY VERTICAL SUPPORT TO THE BUILDING.

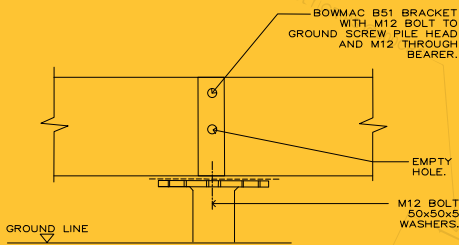

BEARER FIXING TYPE A

SCALE 1:10

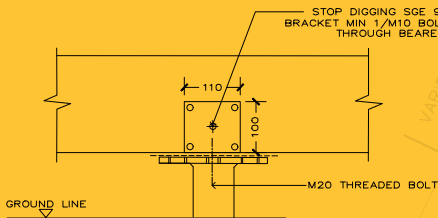

BEARER FIXING TYPE B

SCALE 1:10

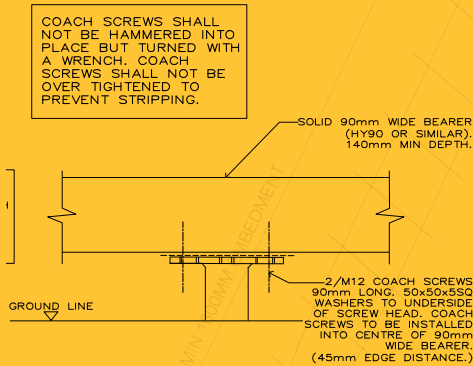

BEARER FIXING TYPE C

SCALE 1:10

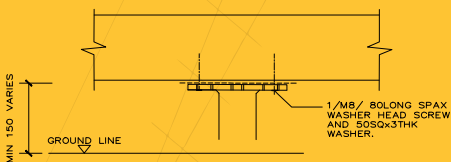

BEARER FIXING TYPE D

SCALE 1:10

DURABILITY NOTES:

GROUND SCREWS ARE TO BE SUPPLIED WITH AN AVERAGE COATING THICKNESS OF >150µm

TREATMENT OF FIXINGS, NAILS, BOLTS .ETC NOT NOTED ON THE DRAWINGS ARE TO BE SELECTED FROM TABLE 4.1 NZ3604.

ZONE	FIXING/FASTENING	ENVIRONMENT	MATERIAL
ZONE D	ALL STRUCTURAL FIXINGS	SHELTERED AND EXPOSED	TYPE 304 STAINLESS
ZONE B AND ZONE C	TREATED TIMBER PILE CONNECTIONS MORE THAN 600mm FROM THE GROUND AND ALL SUBFLOOR CONNECTIONS	SUBFLOOR VENTED 7000mm OR LESS SUBFLOOR VENTED MORE THAN 7000mm.	SHELTERED HOT DIPPED GALVANIZED STEEL
	TREATED TIMBER PILE CONNECTION WITHIN 600mm OF GROUND.	SHELTERED AND EXPOSED..	TYPE 304 STAINLESS STEEL
ALL OTHER STRUCTURAL FIXINGS, EXCEPT FABRICATED BRACKETS	SHELTERED	HOT DIPPED GALVANIZED STEEL	
	EXPOSED	TYPE 304 STAINLESS STEEL	

SEPARATION OF DISSIMILAR MATERIALS IS TO FOLLOW THE OPTIONS BELOW:

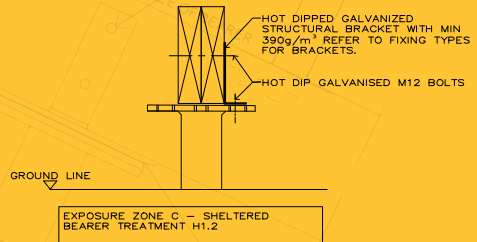

DURABILITY OPTION 1

SCALE 1:10

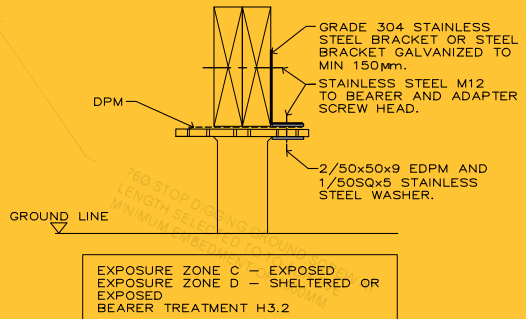

DURABILITY OPTION 2

SCALE 1:10

CLIENT
STOPDIGGING.
DRAWING
GROUND SCREW DETAILS



DRAWING NO

S500

DRAWING DATE

11.11.2020

AMX Structures
Michael Heather CP/Eng 1025672
office@amxstructures.co.nz
0211379834

REV

A

SCALE @ A3

1:10

DECK DESIGN CHECKLIST

STOPDIGGING!



EXEMPTION FROM REQUIRING A BUILDING CONSENT

A building consent is not required for timber decks where it is not possible to fall more than 1.5 metres.

AMX Structures have been engaged to review the ground screw foundations and the fixings to bearers only.

STATEMENT OF COMPLIANCE TO CLAUSE B1 AND B2 OF BUILDING CODE

AMX Structures confirm, on reasonable grounds that the **GROUND SCREWS AND THEIR FIXING TO THE BEARERS**, if constructed in accordance with the information above, the typical connection details on S500, and is maintained in accordance with the schedule below, then it will comply with the relevant provisions of the Building Code B1: B1/VM1, B1/VM4 and B2/AS1 and that the persons who have undertaken the design have the necessary competency to do so.

LIMITATIONS

The following items define the scope of AMX Structure's engagement:

1. The review has been completed on the basis of an IL1 structure, as defined in NZS1170.1;
2. Geotechnical engineering requirements, including but not limited to, land instability and liquefaction, are not included;
3. The location of the deck has not been checked. It is the responsibility of the client to ensure that the deck is located a sufficient distance from legal boundaries and of buried assets (such as sewer pipes, drain pipes, water pipes etc.).

STRUCTURAL MAINTENANCE SCHEDULE

TIMEFRAME	REQUIREMENT
HALF-YEARLY	Wash down all steel brackets and parts of ground screws above ground level
5-YEARLY	Inspect all steel brackets. wire brush any rust and paint with an epoxy enamel external paint.
10-YEARLY	Inspection all steel brackets. Replace or repair coatings with an epoxy enamel external paint

SIGNED ON BEHALF OF AMX STRUCTURES

A handwritten signature in black ink, appearing to read 'Michael Heather'.

Michael Heather MEng(Hons)
CPEng 1025672

STOPDIGGING!®



	SGU	95x580	95x865	95x1000	95x1200	95x1600	
	Art no	10055	1002	1003	1004	1006	
A	Screw thickness	2					mm
B	Screw length	580	865	1000	1200	1600	mm
C	Outer diameter	40	67				mm
D	Helix length	280				600	mm
E	Helix spacing	40					mm
F	Helix height	10					mm
G	Height	100					mm
H	Thickness	5					mm
I	Opening	95					mm
J	Width	70					mm
K	Hole diameter	11					mm

Compression capacity	2,5	6,0	10,5	12,5	17,5	kN
Tensile capacity	1,7	4,5	5,5	6,5	8,0	kN
Lateral capacity	0,5	2,5	3,5	4,5	7,0	kN

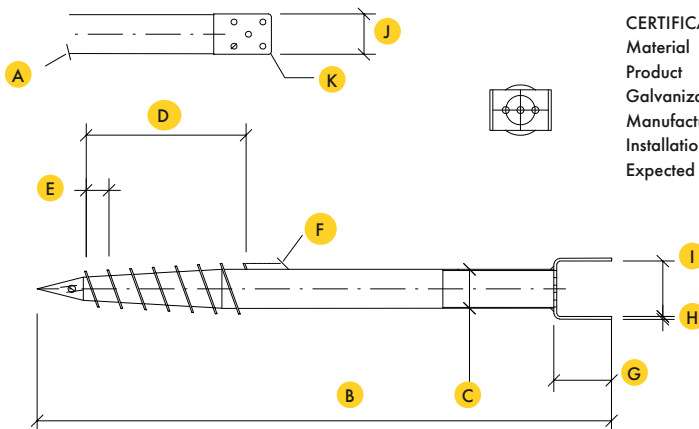

CERTIFICATE

Material
 Product
 Galvanization
 Manufacturing process
 Installation process
 Expected min. service life*

ISO 630 FE 360A
 EN 1090
 EN 1461
 ISO 9001:2015
 ISO 9001:2015
 100 years

* Terms apply, see warranty terms

This document is uncontrolled in printed form.
See www.stopdigging.co.nz for current version.