



**Elephant**

**Plasterboard**

STRENGTH WITH STYLE



# Elephant Plasterboard INSTALLATION GUIDE

May 2023

---

[www.elephantplasterboard.co.nz](http://www.elephantplasterboard.co.nz)

## ABOUT ELEPHANT PLASTERBOARD (NZ) LIMITED

---

Elephant Plasterboard (NZ) Limited is New Zealand's plasterboard and drywall systems marketer and distributor since 1988. As Elephant Plasterboard (NZ) Limited, we offer innovative Bracing, Fire, Noise Control and Wet Area system solutions using our comprehensive range of plasterboard types under Elephant Plasterboard brand.

We continue to distribute the Elephant Plasterboard brand through general building supply outlets and market the brand to the specifiers, developers, housing companies and end users. Our products are available through all major building supply outlets throughout New Zealand

### Elephant Plasterboard Installation Guide

This manual outlines recommended methods for installation, jointing and finishing of Elephant Plasterboard linings in non-fire rated construction. These publications are continuously being updated and superseded.

CURRENT VERSION DATED : **MAY 2023**

It is important to check to ensure you have the latest publication. Call Free Help line 0800 ELEPHANT (353742). Liability for systems that are not designed and installed in accordance with this publication will not be accepted by Elephant Plasterboard (NZ) Limited.

### Copyright

All the material in this document including text, diagrams, figures, patterns, drawings and tables are protected by Copyright.

### Elephant Plasterboard (NZ) Limited Trademarks:

Elephant Plasterboard<sup>®</sup>, Elephant Board<sup>®</sup>,  
Elephant Standard Plasterboard<sup>®</sup>, Elephant Smartboard<sup>®</sup>, SmartRock Plasterboard<sup>®</sup>,  
Elephant FireSmart<sup>®</sup>, Elephant MultiSmart<sup>®</sup>, Elephant AquaSmart<sup>®</sup>, Elephant CeilingSmart<sup>®</sup>,  
Elephant SpanSmart<sup>®</sup>, Elephant SuperSmart<sup>®</sup>, Elephant BraceSmart<sup>®</sup>, Elephant NoiseSmart<sup>®</sup>,  
Elephant UltraSmart<sup>®</sup>, Elephant Standard-Plus<sup>®</sup>, Elephant ImpactSmart<sup>®</sup>

### Free Help line

0800 ELEPHANT (353-742)

### Email

[info@elephantplasterboard.co.nz](mailto:info@elephantplasterboard.co.nz)

### Website

[www.elephantplasterboard.co.nz](http://www.elephantplasterboard.co.nz)

### Telephone

(09) 818-7706

Elephant Plasterboard (NZ) Limited  
14 Bancroft Crescent, Glendene, Auckland 0602  
P.O. Box 21-436, Waitakere 0650  
New Zealand



## CONTENTS

|  |              |
|--|--------------|
| <b>INTRODUCTION</b>                              | <b>4-9</b>   |
| Elephant Plasterboard Product & System Warranty  | 4            |
| Product Description                              | 4            |
| Building Code Compliance                         | 4            |
| Conditions of Use                                | 5            |
| Maintenance                                      | 5            |
| Substitution                                     | 5            |
| Levels of Finish                                 | 6            |
| Product Range                                    | 9            |
| <b>PRE-INSTALLATION</b>                          | <b>10-12</b> |
| Pre-Inspection of the Site Framework             | 10           |
| Framing Spacings                                 | 10           |
| Planning and Measuring                           | 10           |
| Timber Frame Moisture Content                    | 11           |
| Delivery, Handling and Storage                   | 11           |
| <b>GENERAL WALL AND CEILING INSTALLATION</b>     | <b>13-24</b> |
| Inspection of Framing                            | 13           |
| Cutting Elephant Plasterboard                    | 13           |
| Fixing Methods – General                         | 14           |
| Fixing to Ceilings                               | 15           |
| Fixing to Timber Frame Walls – Horizontal Method | 16           |
| Fixing to Timber Frame Walls – Vertical Method   | 17           |
| Fixing to Steel Frame Walls – Horizontal Method  | 18           |
| Fixing to Steel Frame Walls – Vertical Method    | 19           |
| Back-blocking                                    | 20           |
| Curving Elephant Plasterboard                    | 22           |
| Control Joints                                   | 22           |
| Concrete and Masonry Walls – General             | 24           |
| Direct Bonding                                   | 24           |
| Fixing to Furring Channel                        | 25           |
| <b>JOINTING AND FINISHING</b>                    | <b>25-31</b> |
| General  | 26           |
| Jointing Material                                | 26           |
| Storage  | 26           |
| Stopping Recessed Joints - Hand Applied          | 27           |
| Stopping Butt Joints                             | 28           |
| Stopping of Joints - with Mechanical Tools       | 29           |
| Internal & External Corners                      | 30           |
| Cornice Installation                             | 31           |
| Decoration                                       | 32           |
| <b>REPAIRS AND MAINTENANCE</b>                   | <b>33</b>    |
| Accidental Damage                                | 33           |
| Repairing Damaged Pasterboard                    | 34           |



## INTRODUCTION

---

This publication contains within it, the recommended methods for fixing 10mm Elephant Standard and 13mm Elephant Standard Plasterboard. Elephant Plasterboard designed for fire rated systems, bracing systems, wet area systems, and noise control systems are not be fully covered by this publication. It is important that reference is made to separate publications.

### Elephant Plasterboard Product & System Warranty

Elephant Plasterboard wall and ceiling linings are supported by Elephant Plasterboard's Quality Guarantee. This Warranty covers Elephant Plasterboard products and or systems for a minimum of 10 years from the date of the purchase. Elephant Plasterboard supplies products which are warranted to be free from defects. Any products found to be defective before or after installation will be replaced and/or repaired, provided installation has been in accordance with Elephant Plasterboard's technical literature.

### Product Description

Elephant Plasterboard is a strong, dense sheet lining for walls and ceilings and has been specifically manufactured and tested for New Zealand and Australian conditions. It complies with AS/NZS 2588. It can be easily installed by the trades person or home handy person.

The dense pure gypsum core is encased in a high quality face paper and backing paper, produced using a continuous production procedure. This remarkable material is renowned for its stability, acoustic control, bracing and fire resistance.

Along the longitudinal edges sheets are tapered so as to allow reinforcing tapes and plaster in the joints. This is designed to produce a stable crack resistant surface. Square, tapered sheets are also available for horizontal applications.

### Building Code Compliance

Elephant Plasterboard is manufactured to AS/NZS 2588 and has been specifically formulated to meet New Zealand Building Code requirements. Elephant Plasterboard has been marketed internationally since 1975 and the product has established an excellent history of performance for its use in buildings throughout New Zealand and the Asia/Pacific region. Elephant Plasterboard meets the durability requirements of the NZBC and is subject to use, installation and maintenance in accordance with the instructions outlaid in this manual. The Manufacturing plant is International Standard ISO 9001 and ISO 14001 registered.

The NZBC durability requirement under Clause B2.3.1 b) and c) for general linings is between 5 and 15 years depending on the ease of access and replacement.

Elephant Plasterboard systems, used as a general lining, including adhesive fixing when using an adhesive recommended by the manufacturer for this application, satisfy the 15 year durability requirements of the NZBC. Elephant Plasterboard systems fixed mechanically using only screws or nails achieve a 50 year durability performance.

#### Related Documents

##### New Zealand Building Code

##### Approved Documents:

Clause B1 Structure

Clause B2 Durability

Clause F2 Hazardous Building Materials

Clause E2 External Moisture

Clause E3 Internal Moisture

Clause C1-C6 Protection from Fire



## INTRODUCTION

### Limitations and Conditions of Use

- Elephant Plasterboard is intended for normal conditions of dry internal use.
- Elephant Plasterboard must not be used for bracing applications in or around baths and shower areas.
- Elephant Plasterboard must not be exposed to liquid water or be installed in situations where extended exposures to humidity above 90% Relative Humidity are to be expected. Bathrooms, kitchens and laundries should have adequate ventilation or heating to avoid condensation build-up.
- A suitable surface finish (e.g. Vinyl wallpaper or gloss and semi-gloss alkyd paints) must be applied to Elephant Plasterboard in all areas where liquid water or high humidity can be expected.
- Elephant Plasterboard must not be installed over a vapour barrier.
- Elephant Plasterboard must not be applied directly to masonry, concrete or solid plaster, unless timber strapping or steel furring channels are used.
- Elephant Plasterboard must not be exposed to temperatures of 52°C or greater for prolonged periods.
- Elephant Plasterboard may not be used as an external lining.

### Maintenance of Elephant Plasterboard Drywall Systems

The long term durability of an Elephant Plasterboard system is conditional upon, the systems being kept dry in, compliance with the New Zealand Building Code clauses E2 External Moisture and E3 Internal Moisture. This compliance ensures dry internal conditions and alleviates the circumstances which may lead to timber movement, corrosion of metal components, moisture uptake by the gypsum core and fungal growth.

Elephant Plasterboard is a finishing material and must be fully protected during construction from direct sunlight, moisture and direct impact.

The NZBC requires that a fixed appliance shall not raise the temperature of an element to a level that would adversely affect its physical properties. The maximum service temperature for Elephant Plasterboard is 50°C; above which the gypsum core undergoes chemical conversion.

The paper face of the Elephant Plasterboard should be kept intact and care exercised during wet stripping of wallpaper, afterwards the surface made good wherever necessary prior to redecoration. The making good of the paper face is important because plasterboard is a composite laminate and the gypsum core and paper face each contribute to the lining's performance. The making good would include using paper jointing tape and jointing compounds over scratches or cuts in the paper face.

Any surface damage to the paper face or corners caused by normal 'wear and tear', should be made good as soon as practicable otherwise ongoing wear and tear, if it remains unchecked, may lead to the integrity of the board being compromised. If cracks occur at the joints or nail pops occur in the surface of the board, the reason for the problem should be investigated and rectified. The cracks and nail pops should be made good as soon as practicable thereafter. Control joints should be provided to relieve stresses imposed by movement due to moisture, temperature or structural changes. Details of joint design should be obtained from the designer where control joints have been specified to be carried through Elephant Plasterboard linings.

If cracks occur at junctions of bracing elements or at joints in fire or acoustic systems they must be made good immediately. The penetration of fire and noise control systems by unprotected services is detrimental to their performance and must be avoided.

### Substitution

If the systems are not installed in accordance with the guidelines provided in this technical literature, Elephant Plasterboard disclaims all responsibility. All components, framing design, fixing layout and fasteners details must be strictly adhered to in order to ensure the performance of the systems originally specified.



## INTRODUCTION

---

### Levels of Finish

The term Level of Finish applies to plasterboard prior to decoration. There are three level of finishes according to AS/ANZ 2589 - Level 3, Level 4 & Level 5. Different applications for Elephant Plasterboard may require different specifications according to where it is to be used and the level of finish required. The following gives details of how to choose a level of finish for Elephant Plasterboard installations depending upon the final decoration of the room.

#### Level 3

This level of finish is for areas that do not require any decoration or where finish is not important like above ceilings or inside service shafts etc. For use in areas which are to receive heavy or medium texture (spray or hand applied) finishes before final painting, or where heavy grade wall coverings are to be applied as the final decoration. This level of finish is not generally suitable where smooth painted surfaces or light to medium weight wall coverings are specified.

##### > Description

All joints and interior angles must have tape embedded in joint compound and one separate coat of joint compound applied over all joints and fastener heads. All joint compound should be finished smooth. (Generally this is achieved by scraping off nibs and ridges and the like with the edge of a trowel).

#### Level 4

This is the default and generally accepted level of plasterboard finish. For use where light textures or wall coverings are to be applied. It is also for non-critical lighting areas where flat and low sheen paints are to be applied. In critical lighting areas, flat paints applied over light textures tend to reduce joint photographing. Gloss and semi-gloss paints are not generally suitable over this level of finish.

The weight, texture and sheen level of wall coverings applied over this level of finish should be carefully evaluated. Joints and fasteners must be adequately concealed if the wall covering material is lightweight, contains limited pattern, has a gloss finish, or has any combination of these features.

##### > Description

All joints and interior angles must have tape embedded in joint compound and a minimum of two separate coats of joint compound applied over all joints, angles, fastener heads and accessories. All joint compound should be finished smooth and free of tool marks and ridges.

#### Level 5

This level of finish is for use where gloss or semi-gloss paints are specified or where critical lighting conditions occur. Level 5 finish is characterised by a parity of surface texture and porosity.

##### > Description

All joints and interior angles must have tape embedded in joint compound and a minimum of two separate coats of joint compound applied over all joints, angles, fastener heads and accessories. All joint compound should be finished smooth and free of tool marks and ridges. This should be followed by proprietary surface preparations or (in some areas) skim coating to remove differential surface textures and porosity. Local advice should be sought prior to finish for gloss paints or in areas of critical lighting.

#### Skim Coating

Skim coating is a term denoting a thin finish coat, trowelled or airless sprayed to achieve a smooth finish. It is a thin coat of joint compound over the entire surface to fill imperfections in the joint work, smooth the paper texture and provide a uniform surface for decorating. Skim coatings would not normally exceed 1mm in finished thickness.

For further details on the factors affecting levels of finish, reference should be made to the following:  
Australia/New Zealand Standard: Gypsum Lining – Application and Finishing AS/NZS 2589:2017.





# INTRODUCTION

## Levels of Finish Selection Chart

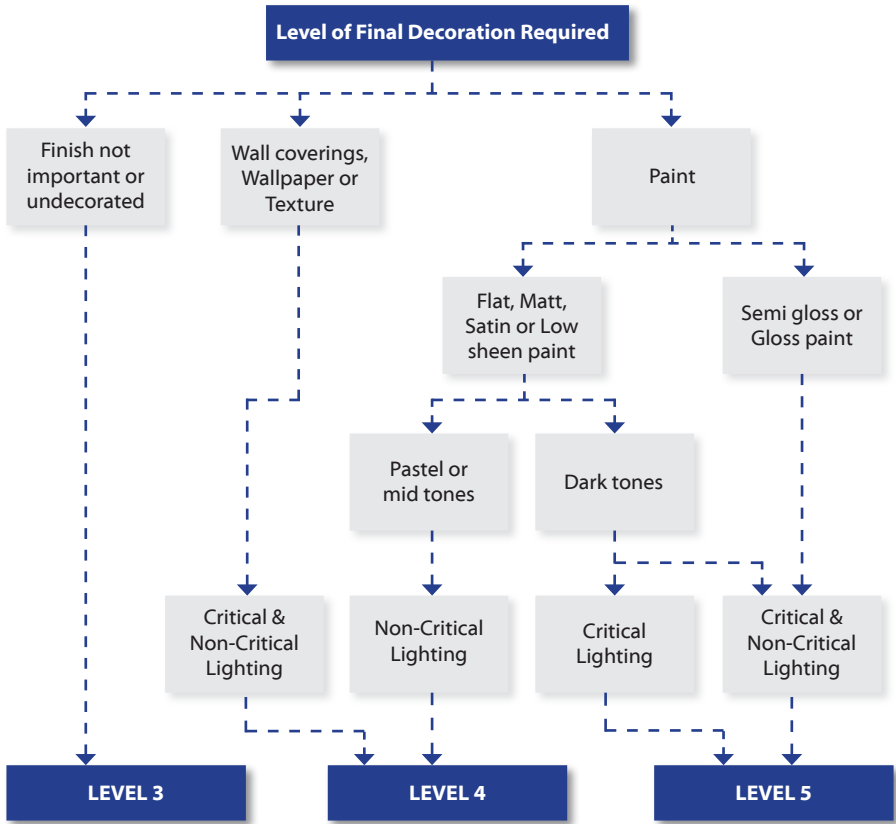

## INTRODUCTION

### Levels of Finish Requirement Summary

|                | <b>Framing Requirements:</b><br>Max deviation of framing members over a 1800mm straight edge | <b>Ceiling Butt Joints Back Blocking</b>         | <b>Ceiling Taper Joints Back Blocking</b>   | <b>Wall Butt Joints</b>   | <b>Joints</b>   |
|----------------|--|--|---|---|---|
| <b>Level 3</b> | 90% area : 4mm<br>10% area:<br>less than 5mm   | must be back blocked and stagger joints by 600mm | back blocking is optional but recommended   | can be located on framing members or back blocked between studs | tape embedded in joint compound +<br>1 coat of joint compound                             |
| <b>Level 4</b> |  |  | must be back blocked for area with:<br>- 3 or more recessed joints (for timber battens),<br>- 6 or more recessed joints (for steel battens)<br>- suspended ceiling does not require back blocking | can be located on framing members or back blocked between studs | tape embedded in joint compound +<br>2 separate coats of joint compound                   |
| <b>Level 5</b> | 90% area : 3mm<br>10% area:<br>4mm or less   |  | all joints must be back blocked   | all joints must be back blocked                                 | tape embedded in joint compound +<br>2 separate coats of joint compound +<br>Skim coating |

#### General Key points that applies to all 3 Level of finishes:

- Horizontal sheet fixing is recommended as it considerable reduces number of sheet joints.
- NZS 3602 recommends moisture content of timber framing to be 18% or less at the time of lining, if heat pumps or air conditioning are to be installed
- Joints around openings must not occur within 200mm to the edge of the opening.
- Control joints to be positioned at 12m centres on either direction.
- Sheet end butt joints to be back blocked and staggered by 600mm.

This table above is a summary of various levels of finish. For the full description of levels of finish and guidelines on assessment of finished surfaces refer AS/NZS 2589:2017 Gypsum linings — Application and finishing.



## INTRODUCTION

### Product Range

#### Product Weights and available Lengths

| THICK-NESS | ELEPHANT PLASTERBOARD PRODUCT RANGE | EDGE TYPE | WIDTH | WEIGHT<br>Kg per m <sup>2</sup> | LENGTH |      |      |      |      |      |      |      |   |
|------------|-------------------------------------|-----------|-------|---------------------------------|--------|------|------|------|------|------|------|------|---|
|            |                                     |           |       |                                 | 2.4m   | 2.7m | 3.0m | 3.3m | 3.6m | 4.2m | 4.8m | 6.0m |   |
| mm         |                                     |           | mm    |                                 |        |      |      |      |      |      |      |      |   |
| 10         | Standard                            | TE/TE     | 1200  | 6.9                             | ✓      | ✓    | ✓    | ✓    | ✓    | ✓    | ✓    | ✓    | ✓ |
| 10         | Standard Horizontal                 | TE/SE     | 1200  | 6.9                             | ✓      |      | ✓    |      | ✓    | ✓    | ✓    | ✓    | ✓ |
| 10         | Standard Horizontal - Wide          | TE/SE     | 1350  | 7.4                             |        |      |      |      | ✓    |      | ✓    | ✓    | ✓ |
| 13         | Standard                            | TE/TE     | 1200  | 8.9                             | ✓      | ✓    | ✓    | ✓    | ✓    | ✓    | ✓    | ✓    | ✓ |
| 10         | CeilingSmart                        | TE/TE     | 1200  | 7.4                             | ✓      | ✓    | ✓    |      | ✓    |      | ✓    | ✓    | ✓ |
| 10         | FireSmart                           | TE/TE     | 1200  | 7.4                             | ✓      | ✓    | ✓    |      | ✓    |      | ✓    | ✓    | ✓ |
| 13         | FireSmart (MultiSmart)              | TE/TE     | 1200  | 11.8                            | ✓      | ✓    | ✓    | ✓    | ✓    |      |      |      |   |
| 16         | FireSmart                           | TE/TE     | 1200  | 14.2                            | ✓      | ✓    | ✓    |      |      |      |      |      |   |
| 10         | MultiSmart                          | TE/TE     | 1200  | 9.0                             | ✓      | ✓    | ✓    |      | ✓    |      |      | ✓    |   |
| 10         | MultiSmart Horizontal               | TE/SE     | 1200  | 9.0                             |        |      |      |      |      |      |      | ✓    |   |
| 13         | MultiSmart                          | TE/TE     | 1200  | 11.8                            | ✓      | ✓    | ✓    | ✓    | ✓    |      |      |      |   |
| 10         | AquaSmart                           | TE/TE     | 1200  | 8.4                             | ✓      | ✓    | ✓    |      | ✓    |      |      |      |   |
| 10         | AquaSmart Horizontal                | TE/SE     | 1200  | 8.4                             | ✓      |      |      |      |      |      |      | ✓    |   |
| 13         | AquaSmart                           | TE/TE     | 1200  | 11.2                            | ✓      | ✓    | ✓    |      | ✓    |      |      |      |   |

TE/TE = Tapered Both Edges

TE/SE = Tapered One Edge, Square the Other

#### Product Primary Functions\*

| THICK-NESS | ELEPHANT PLASTERBOARD PRODUCT RANGE | EDGE TYPE | WIDTH | Horizontal Fixing | Span 600 Centres on Ceilings | Bracing | Fire Resistance | Noise Control | Impact Resistant | Water Resistant |
|------------|-------------------------------------|-----------|-------|-------------------|------------------------------|---------|-----------------|---------------|------------------|-----------------|
|            |                                     |           |       |                   |                              |         |                 |               |                  |                 |
| mm         |                                     |           | mm    |                   |                              |         |                 |               |                  |                 |
| 10         | Standard                            | TE/TE     | 1200  |                   |                              | ✓       | ✓               |               |                  |                 |
| 10         | Standard Horizontal                 | TE/SE     | 1200  | ✓                 |                              | ✓       |                 |               |                  |                 |
| 10         | Standard Horizontal -Wide           | TE/SE     | 1350  | ✓                 |                              | ✓       |                 |               |                  |                 |
| 13         | Standard                            | TE/TE     | 1200  |                   | ✓                            |         | ✓               |               |                  |                 |
| 10         | CeilingSmart                        | TE/TE     | 1200  |                   | ✓                            | ✓       | ✓               |               |                  |                 |
| 10         | FireSmart                           | TE/TE     | 1200  |                   | ✓                            | ✓       | ✓               |               |                  |                 |
| 13         | FireSmart (MultiSmart)              | TE/TE     | 1200  |                   | ✓                            | ✓       | ✓               | ✓             | ✓                |                 |
| 16         | FireSmart                           | TE/TE     | 1200  |                   |                              |         | ✓               | ✓             | ✓                |                 |
| 10         | MultiSmart                          | TE/TE     | 1200  |                   | ✓                            | ✓       | ✓               | ✓             |                  |                 |
| 10         | MultiSmart Horizontal               | TE/SE     | 1200  | ✓                 |                              | ✓       |                 |               |                  |                 |
| 13         | MultiSmart                          | TE/TE     | 1200  |                   | ✓                            | ✓       | ✓               | ✓             | ✓                |                 |
| 10         | AquaSmart                           | TE/TE     | 1200  |                   |                              |         | ✓               | ✓             |                  | ✓               |
| 10         | AquaSmart Horizontal                | TE/SE     | 1200  | ✓                 |                              |         |                 |               |                  | ✓               |
| 13         | AquaSmart                           | TE/TE     | 1200  |                   | ✓                            |         | ✓               | ✓             |                  | ✓               |

\* The above table details the product's Primary functions.

Some products may perform more than the functions indicated



## PRE-INSTALLATION

### Pre-Inspection of the Site Framework

- Check that the framing is plumb, level and square and has been erected according to the relevant building specification. The framing must have a minimum flat face width of 35mm for timber and 32mm for steel.
- Plumbing and electrical services should be installed before the plasterboard is fixed and all service ducting, pipes, outlets and switch boxes should be set back from the framing and not protrude beyond the face of the framing.
- Make sure all contact surfaces of the framing are dry and free from dirt, grease, oil or any other foreign material.
- Where level 3, 4 or 5 finishes are specified (see heading **Levels of Finish** on page 6) the deviation in the position of the bearing surface of the framing from a 1.8m straight edge shall not exceed 2mm when measured over a 1.8m span at any point along individual members or across adjacent members.

Note – The fixing of Elephant Plasterboard is deemed to be an acceptance of the substrate, so it is important to make sure that the above requirements are adhered to.

### Framing Spacings

The spacing of framing support for Elephant Plasterboard linings shall not be greater than 600mm centres for all thicknesses of Elephant Plasterboard.

The requirements for wall and ceiling framing spacings are detailed below.

| Location | Thickness and Type       | Framing Centres |
|----------|--------------------------|-----------------|
| Wall     | 10mm Standard or greater | 600mm           |
| Ceiling  | 10mm Standard            | 450mm           |
|          | 10mm CeilingSmart        | 600mm*          |
|          | All other board types    | 600mm*          |

\* It is recommended that framing centres on ceilings be kept at 450mm in Bathrooms or other areas that may be subject to moisture and steam when using 10mm plasterboard. On ceilings we recommend the use of steel battens, as timber battens can be subject to expansion and contraction.

### Planning and Measuring

- Good planning of sheet layout is important. This will reduce wastage and keep the number of joints to a minimum, saving time and extra costs.
- On ceilings the use of maximum sheet sizes minimises the occurrence of end butt joints. Where end butt joints occur they must be formed, preferably, between framing members where joints can be neatly finished using the “back-blocking” method (see pages 20,21).
- On walls, sheets may be fixed either vertically or horizontally and should ideally run right through and over doors and windows. The window and door openings are then able to be cut out when sheets are in place.
- Joints should not occur within 200mm of door or window frame corners or on jamb studs as this is a point of stress.

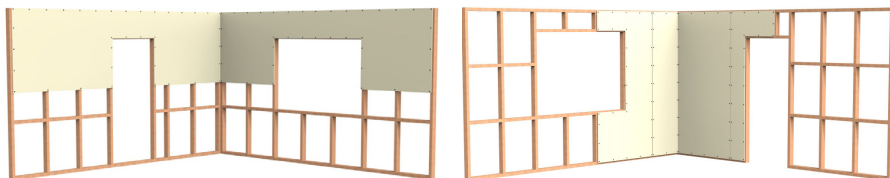

## PRE-INSTALLATION

### Timber Frame Moisture Content

When Elephant Plasterboard is fixed to timber containing excessive moisture, problems may occur which can affect the finished appearance of the wall or ceiling. These can occur in the form of –

- The appearance of mould as the moisture migrates through the plasterboard.
- Nails or screws popping from timber shrinkage.
- Joints cracking when frame expands.
- Joints peaking when the frame shrinks as it dries.

To achieve a level 3, 4 or 5 finish, timber must have a moisture content of between 12–18% (inclusive) at the time of lining. This is a requirement of the substrate for the direct fixing of Elephant Plasterboard. Overly dry timber at time of lining (especially in Summer months) can result in cracking of joints because when moisture is re-absorbed in wetter seasons timber framing begins to expand.

Consider back-blocking on the tapered joints of horizontal fixed sheets, especially on wall heights over 2.7 metres.

- Install Plasterboard when the timber moisture content is within 2% of the final expected ambient moisture content.
- It is recommended to use steel battens on ceilings.
- If timber battens are unavoidable it is also recommended that the moisture content of the timber battens should not exceed 16% at the time of lining.

For more information see BRANZ Good Practice Guide: Internal linings (2nd edition).

### Delivered to Site Service

Elephant Plasterboard offers Delivered to Site (DTS) services. Note the DTS service is not available to all areas. Contact Elephant Plasterboard 0800 353 742 for details.

#### Plasterboard Ready Site

Sites must be clear of any obstructions (building waste or scaffolding) to receive deliveries otherwise re-delivery charges and delays will apply. The site must be plasterboard ready with clear and unobstructed access. The site must be checked and ensured it is free of hazards, all rubbish and scaffolding removed to allow a clear parking space for the delivery truck and a clear pathway for the plasterboard to be carried.

#### Site Check

During the order process, the customer must confirm that the site is 'plasterboard ready', thereby meeting the safety recommendations. A site check is compulsory for all Commercial Building sites, for orders over 8 tonne or sites located on a steep hill. When in doubt, Contact our Elephant Plasterboard Team and request a Site check to avoid failed delivery.

Our Standard Deliveries are included in DTS price. Extra charges apply in case of specialised deliveries that involves:

- plasterboard being carried more than 20 meters or
- plasterboard to be carried upstairs or
- the foundation height is over 400mm or
- if the delivery is split into more than two areas or
- if the unloading time exceeds 2 hours on site or
- involves long reach hiab (15-23m) or Super long reach hiabs (23-32m)



## PRE-INSTALLATION

### Handling & Storage

- Where possible Elephant Plasterboard should be delivered to site just prior to installation as this greatly reduces the possibility of damage.
- All materials should be kept dry, preferably by being indoors and under cover (especially when storage is likely to be for a lengthy period). While stored plasterboard should be protected from moisture and direct sunlight.
- Cracked or damaged sheets must not be used.
- Sheets should be neatly stacked horizontally where possible to avoid sheet distortion, damage or moisture ingress. This can be achieved by stacking on a clean flat surface that is not susceptible to moisture.
- When stacking on concrete floors, use a moisture barrier (e.g. Polythene sheet or place on bearers parallel to the ends of the linings and extending full width of the sheet at no more than 600mm centres).
- Maximum height when stacked horizontally on a suspended floor is limited to 300mm to minimise the risk of structural damage.
- The front face of the sheets should be kept face down to prevent footprints and other marks or damage to the face.
- Floor Loadings should be considered as the Elephant Plasterboard can weigh in the range of 700–900 kg/m<sup>3</sup>.
- When floor space is limited, plasterboard can be stored vertically by leaning the sheets against a wall 150–180mm from the bottom plate.
- To reduce the risk of sheets falling, restraints must be used when plasterboard is stacked vertically.
- Maximum number of sheets when stacked against a wall: 10mm or 13mm – 18 sheets, 16mm – 12 sheets.
- During handling and storage, sheets should be carried in an 'upright' position with particular care taken to protect the edges ends or surfaces.

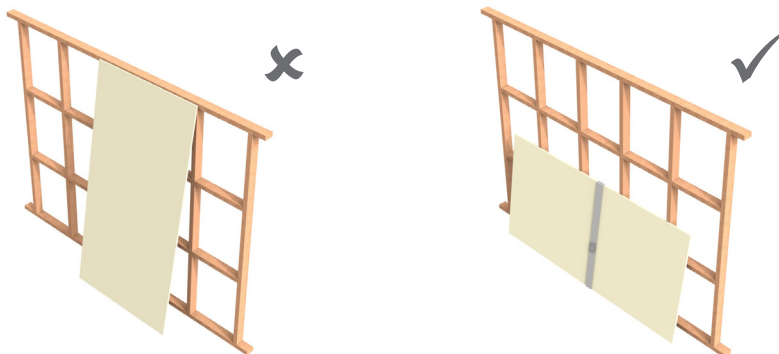

**Vertical Stacking**

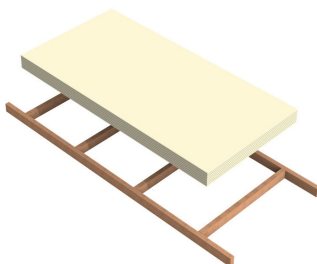

**Horizontal Stacking**

## GENERAL WALL AND CEILING INSTALLATION

The following section covers the installation of Elephant Plasterboard in general wall and ceiling applications. For information regarding Bracing, Acoustic and Fire Systems installation refer to the appropriate literature.

### Inspection of the Framing

- Flatness of Framing  
Inspect the surface of the framing and ensure that it is flat. In particular take note of nails not seated below the surface, nogs not flush, hold down straps not checked in flush to the surface etc.
- Moisture Content of the Framing  
Reliance should not be made on the building inspector alone at pre-line stage. It is important to ensure the framing is dry and to understand the effects of framing moisture on the overall finish of the wall and ceiling linings.
- Insulation Material  
Ensure that insulation material is not bulging out of the framing. Otherwise this will apply pressure on the lining material and may cause screw or nail popping.

These issues must be corrected prior to the fixing of the lining materials to the framing. Once fixing starts, this indicates that there has been an acceptance of the substrate quality. Therefore it is the responsibility of the framing contractor to ensure that the substrate will allow the fixer to fix in accordance with manufacturers instructions and recommendations.

Furthermore it is important for the fixer to provide a suitable surface, for the plasterboard stopper to conduct the stopping process in an effective way.

### Cutting Elephant Plasterboard

- Elephant Plasterboard is easily cut by scoring or sawing with all markings done on the face of the board.
- When scoring use a sharp drywall knife and straight edge on the paper face. Once scored, the board may be snapped away from the cut face and then score the back paper to finish the cut.
- Cut-outs for switch boxes and other penetrations should be scored on both surfaces using a drywall knife or a keyhole saw, before trying to remove waste board. Care should be taken to avoid damaging the core during this procedure.

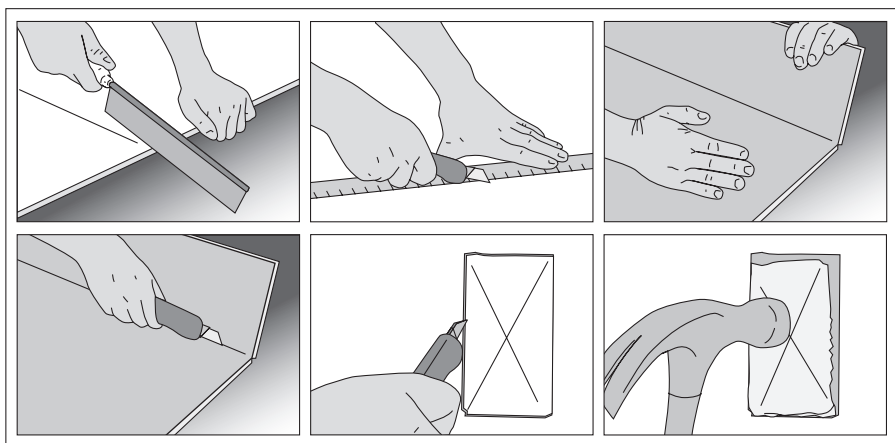

## GENERAL WALL AND CEILING INSTALLATION

### Fixing Methods

#### General

- Elephant Plasterboard must be fixed leaving a gap of approximately 5-10mm at the floor level to allow for movement of framing members.
- All nails and screws should be driven in to the plasterboard at right angles and to a depth so that heads are seated in a slight recess.
- Daubs of wallboard adhesive should be about 30mm in diameter.
- Never place the mechanical fixings within 200mm of wallboard adhesive.
- Always keep the mechanical fixings 12mm from the sheet edge and 18mm from sheet ends.
- For bracing elements fixing refer Elephant QuickBrace Manual.

#### Walls

There are two approved methods for fixing plasterboard to framing members – **Horizontal Fixing** – Board fixed at right angles to the studs. **Vertical Fixing** – Board fixed parallel to the studs.

By fixing sheets using the horizontal method the number of joints is considerably reduced giving a generally higher quality wall finish. Plasterboard also has greater strength along its length so will offer more support between spans when fixed this way. Where the face of the framing member is reduced, horizontal fixing is also preferred as it is more difficult to fix two sheets on the smaller surface.

- When fixing over doors and windows it is recommended that joints do not occur on door and window studs. Sheets should be fixed horizontally and waste plasterboard cut out after it has been fixed.
- Joints should not occur within 200mm of door or window frame corners or on jamb studs as this is a point of stress.

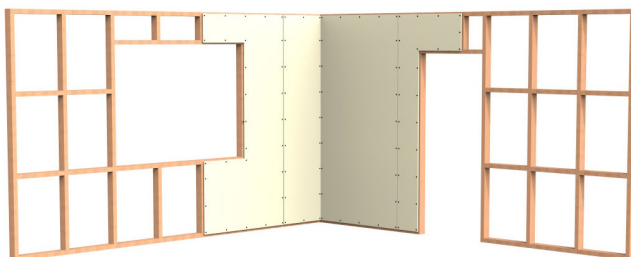

Vertical Fixing

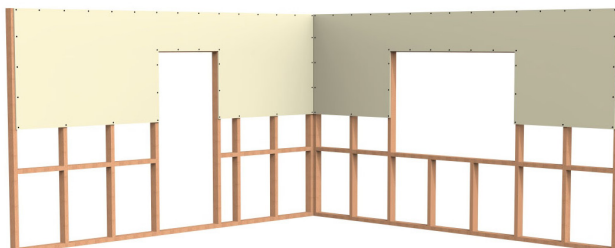

Horizontal Fixing

## GENERAL WALL AND CEILING INSTALLATION

### Fixing to Ceilings

#### Adhesive/Screw

- Fix ceiling sheets across battens or joists.
- Steel battens are recommended.
- Refer to table on page 8 for suitable board thickness and framing centres.
- Apply adhesive to battens or joists at 200mm centres between centre and edge of sheet.
- Start fixing from the centre of each sheet outwards.
- Position the sheet hard up to the framing, single screw at the centre line and the edges across each batten.
- Nailing is not recommended.
- Single screws to be minimum 12mm from sheet edge and 18mm from sheet ends.
- Press the plasterboard where adhesive has been applied to ensure full contact.
- Sheet end joints must not be made on framing and must be back-blocked.
- Back-blocking of sheet ends and recessed joints is essential for a high quality finish. (See table on page 17).
- Fix the edges of the sheet at the wall junction at 200mm centres.
- Adhesive must not be applied to the sheet edges or under screws. This may contribute to screw popping.
- All joints between sheets should be touch fitted.
- Use long length sheets to minimise sheet end butt joints.
- The use of a drywall lifter will greatly assist the builder in achieving optimum results.

#### Fasteners

|               |   |
|---------------|---|
| Steel Battens | 25mm x 6 gauge self tapping drywall screws  |
| Timber        | 32mm x 6 gauge coarse thread drywall screws |

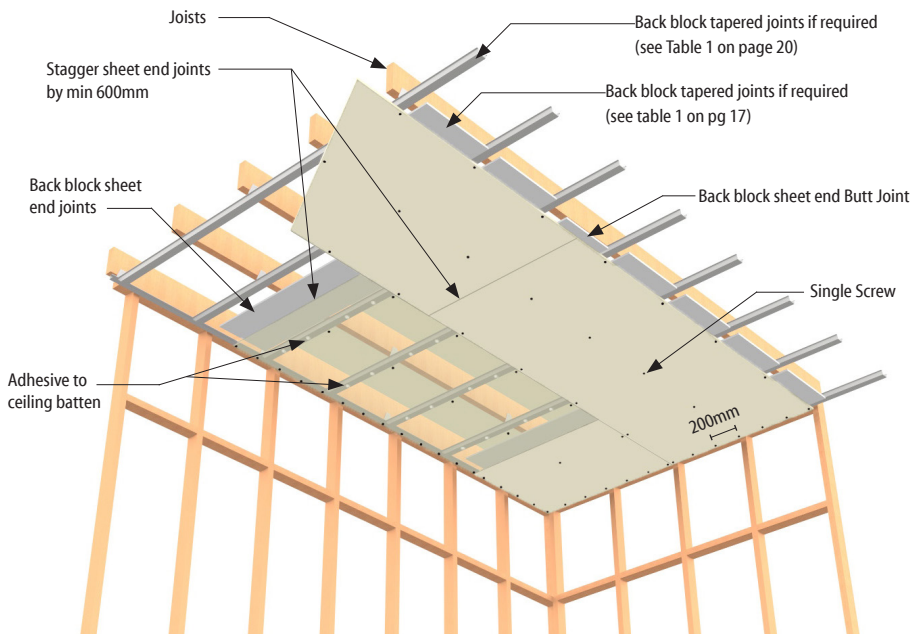

## GENERAL WALL AND CEILING INSTALLATION

### Fixing to Walls – Timber Frame Horizontal Method

#### Wall Framing

Dimensions for framing must comply with NZS3604:2011 requirements.

- Timber Framing moisture content should be between 12–18% when lining is installed.
- Studs must be spaced at 600mm centres maximum when using either 10mm or 13mm Elephant Plasterboard.
- For wall heights up to 2700mm use either
  - (a) 2 rows of nogs spaced evenly or
  - (b) 1 row of nogs staggered to a max 50mm - 75mm from either side of centre line.
- Where the stud height is between 2400–2700mm, Elephant Plasterboard has 1350mm wide sheets to install horizontally.
- An additional row of nogs is required for wall heights up to 3600mm.
- Sheet end joints made on framing should be staggered 600mm by fixing to different studs.
- Adhesive must not be applied to the sheet edges or under mechanical fixings. This may lead to screw or nail popping.
- All joints between sheets should be touch fitted.

#### Fastening the Linings

- Leave a 5–10mm gap at the floor level to allow for movement in timber framing.
- Apply adhesive to intermediate studs at maximum 300mm centres.
- Fix the top sheet first.
- Screws or nails should be fixed no less than 12mm from the sheet edge or 18mm from sheet ends.
- Place the fasteners at the wall corners in a room at 50mm in from each direction.
- Single screw fastenings at 300mm centres to top and bottom plates and sheet ends. Screw single fastenings through the centre of the wall at the point where the horizontal joint crosses the stud.
- Screw fasteners at 300mm centres around all wall openings.
- Firmly press the plasterboard where adhesive has been applied to ensure full contact.

| Fasteners                    | 10mm           | 13mm           |
|------------------------------|----------------|----------------|
| Coarse Thread Drywall Screws | 25mm x 6 gauge | 32mm x 6 gauge |

Some EPB performance systems require different fastener lengths and types. Refer relevant EPB technical literature for more information.

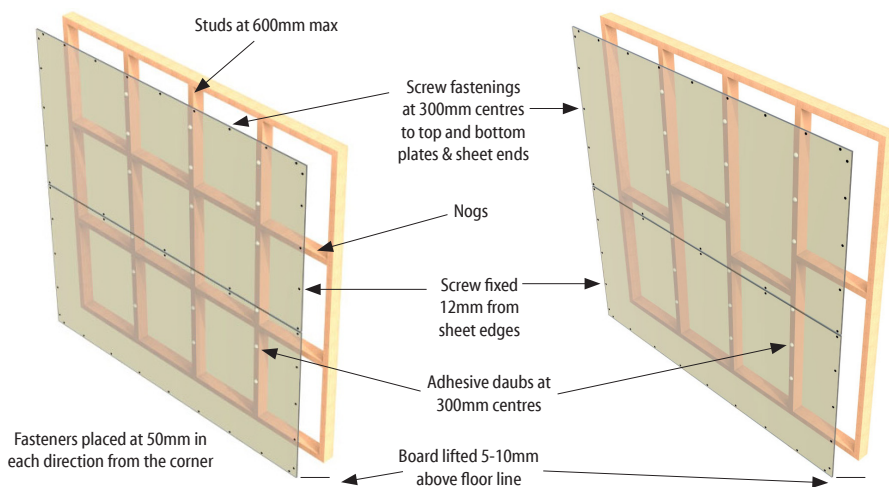



## GENERAL WALL AND CEILING INSTALLATION

### Fixing to Walls – Timber Frame Vertical Method

#### Wall Framing

Dimensions for framing must comply with NZS3604:2011 requirements.

- Timber Framing moisture content should be between 12-18% when lining is installed.
- Studs must be spaced at 600mm centres maximum when using either 10mm or 13mm Elephant Plasterboard.
- For wall heights at 2400mm high, nogs need to be set at 800mm centres.
- For wall heights at 2700mm high, nogs need to be set at 900mm centres.

#### Fastening the Linings

- Leave a 5–10mm gap at the floor level to allow for movement in timber framing.
- Apply adhesive to intermediate studs at maximum 300mm centres.
- Firmly press the plasterboard where adhesive has been applied to ensure full contact.
- Fasteners should be at 300mm centres around the sheet perimeter.
- Screws should be fixed no less than 12mm from the sheet edge or 18mm from sheet ends.
- Adhesive must not be applied to the sheet edges or under nails or screws. This may lead to nail or screw popping.
- All joints between sheets should be touch fitted.

| Fasteners                    | 10mm           | 13mm           | 16mm           |
|------------------------------|----------------|----------------|----------------|
| Coarse Thread Drywall Screws | 25mm x 6 gauge | 32mm x 6 gauge | 41mm x 6 gauge |

Some EPB performance systems require different fastener lengths and types. Refer relevant EPB technical literature for more information.

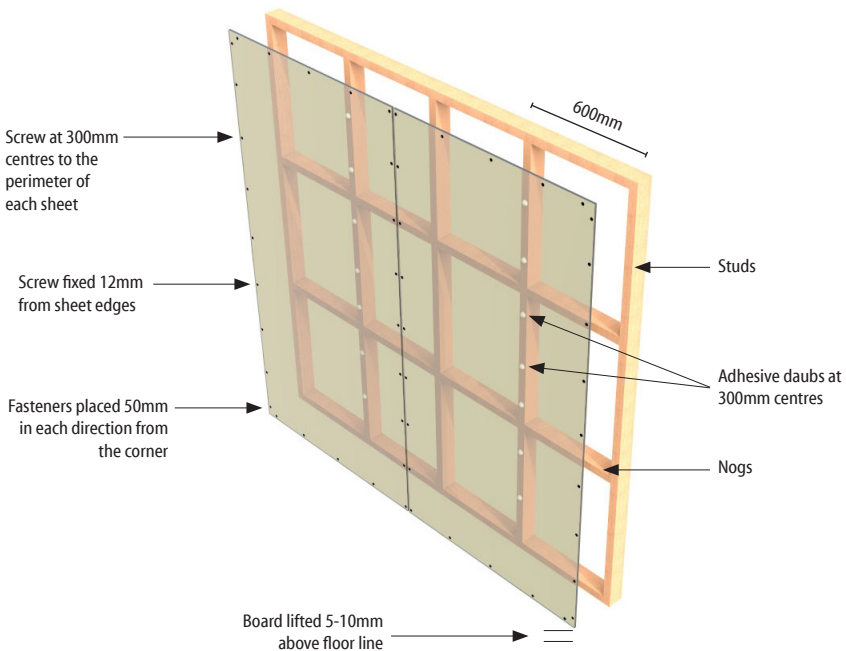

## GENERAL WALL AND CEILING INSTALLATION

### Fixing to Walls – Steel Framing Horizontal Method

#### Wall Framing

- Steel stud dimensions should be 63 x 34 x 0.55mm minimum with a 6mm return.
- Steel channel dimensions should be 63 x 30 x 0.55mm minimum.
- Stud spacing should be at 600mm centres maximum.
- Studs need to be placed with the open side facing in the same direction.
- The correct order for attaching the board is crucial, as the face of the steel stud can deflect initially.

The first board will deflect slightly when attached to the open side of the stud, but when the screw is fully tightened it will pull back tight against the board. There will be minimal deflection when the second sheet is attached, as the open flange is now supported by the first one. Support the stud to avoid twisting.

#### Fastening the Linings

- Leave a 5–10mm gap at the floor level. Sheets can be fixed hard to the floor if friction fitted steel studs are used.
- Apply adhesive or screws to intermediate studs at maximum 300mm centres.
- Screws should be fixed no less than 12mm from the sheet edge.
- Screw single fastenings at 300mm centres to top and bottom channels and at end studs.
- At wall corners, screws to be placed 50mm in each direction from the corner.
- Single screw to each stud where the horizontal joint crosses the studs.
- Joints made on framing should be staggered 600mm by fixing to different studs.
- Adhesive must not be applied to sheet edges or under screws. This may lead to screws popping.
- All joints between sheets should be touch fitted.
- For stud heights greater than 2.4m, 13mm Plasterboard or greater is required.

| Fasteners                       | 10mm - 13mm    | 16mm           |
|---------------------------------|----------------|----------------|
| Self-Tapping fine thread screws | 25mm x 6 gauge | 32mm x 6 gauge |

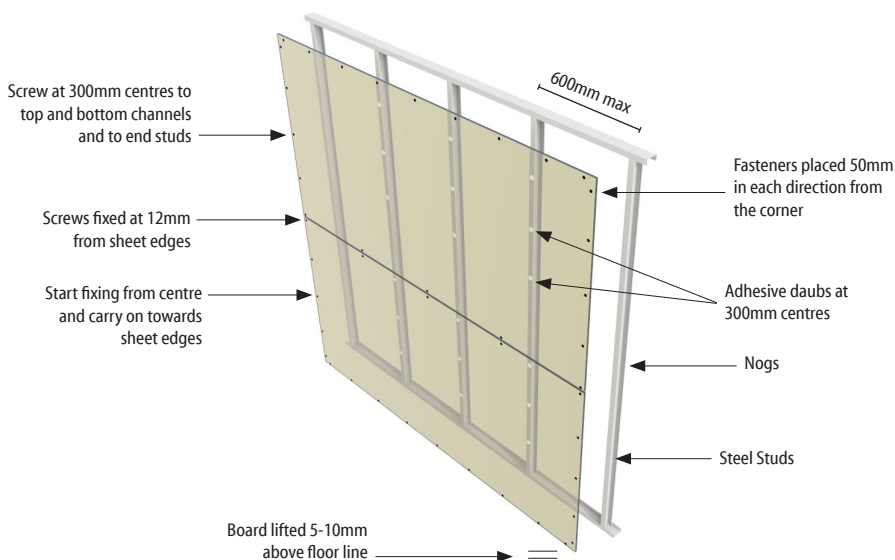

## GENERAL WALL AND CEILING INSTALLATION

### Fixing to Walls – Steel Framing Vertical Method

#### Wall Framing

- Steel Stud dimensions should be 63 x 34 x 0.55mm minimum with a 6mm return.
- Steel channel dimensions should be 63 x 30 x 0.55mm minimum.
- Stud spacing should be at 600mm centres maximum.
- Studs need to be placed with the open side facing in the same direction.

The correct order for attaching the board is crucial, as the face of the steel stud can deflect initially. The first board will deflect slightly when attached to the open side of the stud, but when the screw is fully tightened it will pull back tight against the board. There will be minimal deflection when the second sheet is attached, as the open flange is now supported by the first one. Support the stud to avoid twisting.

#### Fastening the Linings

- Leave a 5–10mm gap at the floor level. Sheets can be fixed hard to the floor if friction fitted steel studs are used.
- Apply adhesive or screws at maximum 300mm centres to intermediate studs.
- Screws should be fixed at no less than 12mm from the sheet edge.
- At wall corners, screws to be placed 50mm in each direction from the corner.
- Start fixing from the sheet centre and work out towards the edge.
- Adhesive must not be applied to the sheet edges or under screws. This may lead to screw popping.
- Joints should be staggered 600mm on opposite sides of the partition.
- All joints between sheets should be touch fitted.
- For stud heights greater than 2.4m we recommend 13mm Plasterboard or greater.

| Fasteners                       | 10mm - 13mm    | 16mm           |
|---------------------------------|----------------|----------------|
| Self-Tapping fine thread screws | 25mm x 6 gauge | 32mm x 6 gauge |

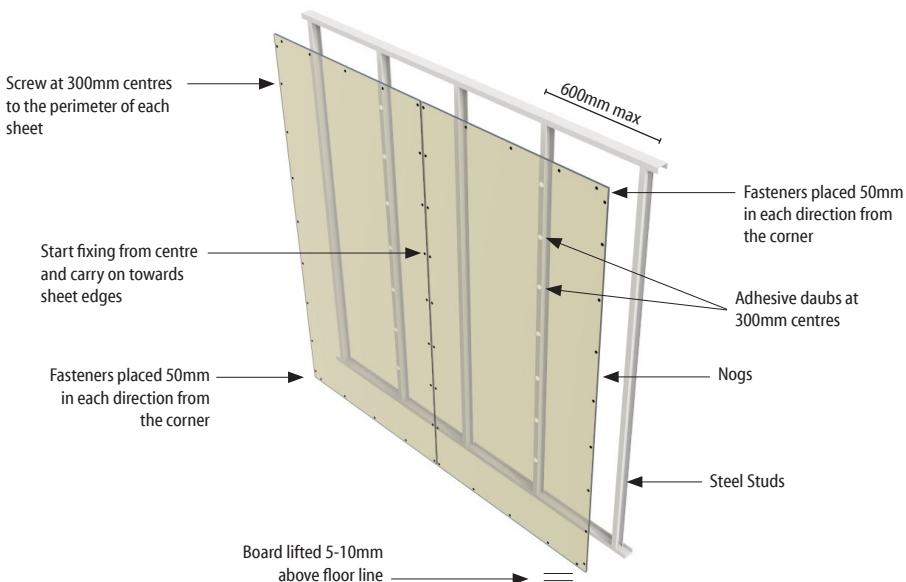

## GENERAL WALL AND CEILING INSTALLATION

### Back-blocking

#### General

Back-blocking is a reinforcing system designed to minimise the deformation and cracking of joints which can occur from a combination of weather conditions and/or building stresses resulting from expansion, contraction or building movement. Back-blocking is generally used where butt or end jointing of sheets occur between framing members and to recessed joints where a high standard of finish is required.

- Do not use panel adhesives for back-blocking as they have high flexibility characteristics.

#### Ceiling recessed edge joints

- Cut back-blocks at least 200mm wide and long enough to fit loosely between the framing members.
- Apply plaster-based setting type adhesive/cement to back-blocks over the full face of the back-block. A notched spreader to give 6mm x 6mm beads at approximately 20mm centres at right angle to the joint would be satisfactory.
- Fix Elephant Plasterboard at right angles to framing members. Place back-blocks centrally along the full length of the board end or edge.
- Immediately after the blocks are in place erect the next board.
- Ceilings back-blocks may be cemented into position from above the ceiling after the boards have been fixed and before they are flush jointed.

### Back-blocking for Ceilings and Walls

#### Ceiling Butt Joints

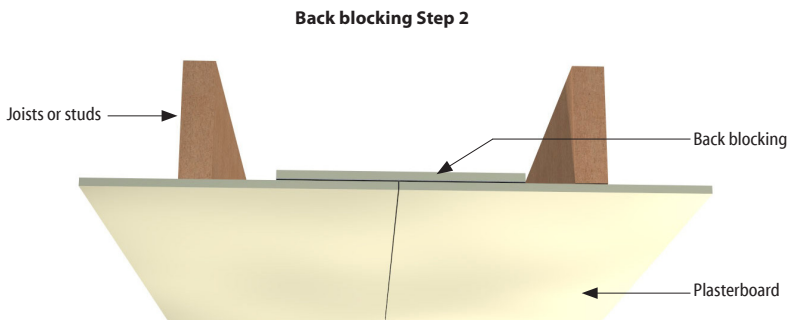
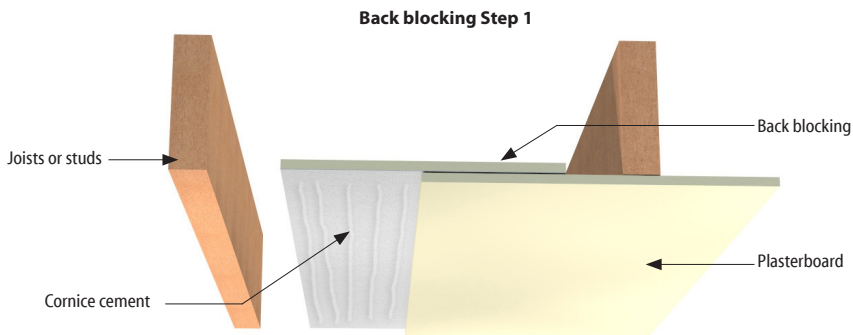

## GENERAL WALL AND CEILING INSTALLATION

### Back-blocking for Ceilings and Walls

- Fix ceiling sheets with ends butted neatly together. The butt joint shall fall within 50mm of the mid-span point between framing members.
- Use battens and packers to support and deflect the sheet ends upwards about 2mm.
- Reinforce the butt joint by back blocking with Elephant Plasterboard cut to fit loosely between the framing across the full width of the sheet and overlapping the edges of adjoining sheets by 50mm.
- Adhere back-blocks with cornice cement applied over the full face of the back-block. A notched spreader to give 6 x 6mm beads at approximately 20mm centres at right angle to the joint would be satisfactory.
- Allow cornice cement to set for a minimum of 24 hours before removing temporary battens. When temporary battens are removed, a hollow formation suitable for jointing remains.
- Back-blocking of sheet ends and recessed joints is essential for a high quality finish. Joints made on framing should be staggered 600mm by fixing to different battens or joists.

#### Back blocking using temporary battens and packer to create a tapered edge

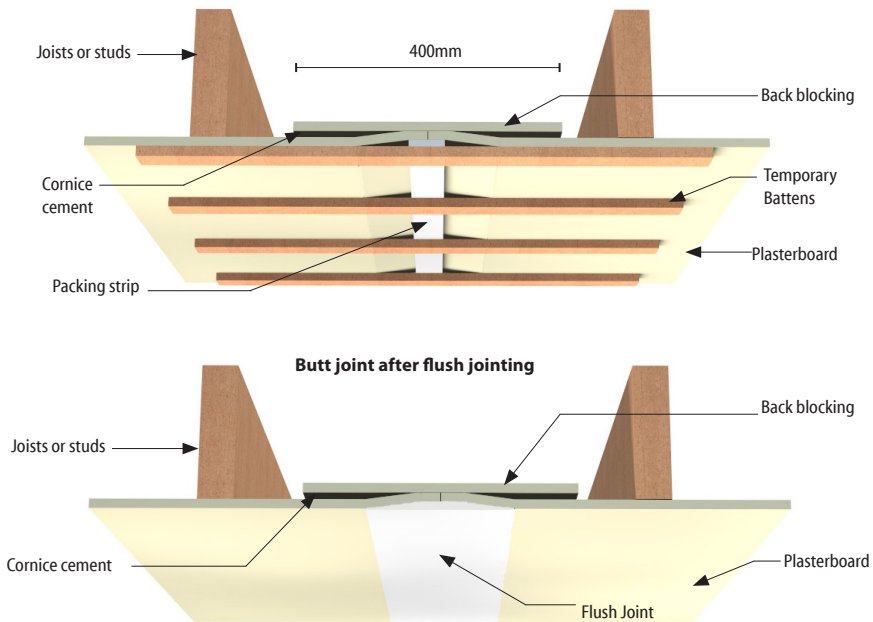

**Table 1 Requirements for Back-blocking**

| Level of Finish | Ceilings |          | Walls |          |
|-----------------|----------|----------|-------|----------|
|                 | Butt     | Recessed | Butt  | Recessed |
| 5               | Yes      | Yes      | Yes   | No       |
| 4               | Yes      | Yes*     | No    | No       |
| 3               | No       | No       | No    | No       |

\*Recessed joints on ceiling must be back-blocked in any area containing 3 or more recessed joints.



## GENERAL WALL AND CEILING INSTALLATION

### Curving Elephant Plasterboard

Elephant Plasterboard can be formed to provide curved surfaces to fit various interior wall and ceiling designs.

- Sheets are to be applied horizontally to walls.
- If sheets are required to be wet then the face that is to be compressed should have water applied with a roller prior to application.
- Allow wet boards to set for 1 hour prior to application.
- Allow 1 litre of water for every 3 sqm of board.
- As the sheets dry the board should retain its original hardness along with its new curve.
- To avoid flat areas between framing, studs may need to be spaced closer than normal.
- Penetrations are not recommended for curved surfaces.
- Adhesive must not be used for fixing damp sheets.

### Minimum Bending Radius of Elephant Plasterboard

| Board Thickness mm | Minimum Radius – Wet | Minimum Radius – Dry |
|--------------------|----------------------|----------------------|
| 10mm Standard      | 1050mm               | 1400mm               |
| 13mm Standard      | 1200mm               | 1700mm               |

### Minimum Vertical Stud Spacings – Radius of Curve (mm)

| Over 1000–1500 | Over 1500–3000 | Over 3000 |
|----------------|----------------|-----------|
| 200            | 300            | 400       |

### Control Joints

Control joints should be provided where there is a potential stress build up from structural movement and changes in temperature and humidity. Potential cracking and stress buildup and be minimised by incorporating control joints sited as follows:

- In long unbroken partition or wall runs, control joints should be inserted at maximum 12m centres in both direction.
- Provide control joints in walls and ceiling at every change of lining materials type. Eg, from plasterboard to fibre cement.
- Door frames or openings extending from floor to ceiling constitute an effective control joint. For doors less than ceiling height, a control joint extending from one corner of the frame may be used.
- Horizontal control joints to be provided at mid-floors in stairwells of multi storey units.
- Extensive interior ceiling areas should have control joints, spaced at maximum 12m centres and may be positioned to intersect lighting fixtures, heating vents or air diffusers.
- Ceiling battens must be discontinued at control joints.

#### Installation

- Allow nominal 20mm gap between the ends of plasterboard sheets.
- Insert the Rondo P35 Control joint in the gap and fix both flanges to the plasterboard by stapling or nailing at 150mm centres maximum.
- Stop and finish the joint with jointing compound.
- Once dry, remove the protective filament tape protecting the centre of the control joint to leave a clean and neat joint.



## GENERAL WALL AND CEILING INSTALLATION

### Control Joints in ceilings

In ceilings, cracks most likely tend to occur in places as indicated below. Control joints are recommended to be located in such places to reduce the risk of cracking.

- a) At corners of openings like skylights
- b) At the internal corners in irregular shaped ceilings
- c) At hallways exiting from a larger ceiling area

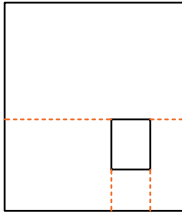

(a)

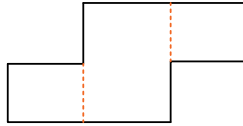

(b)

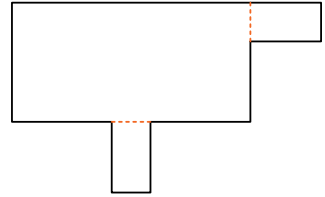

(c)

### Control Joints in ceiling

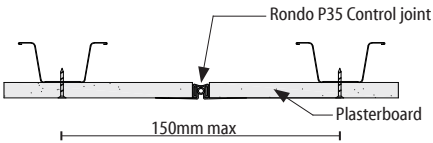

### Horizontal Control Joint at Mid-floor of Two storey full height wall

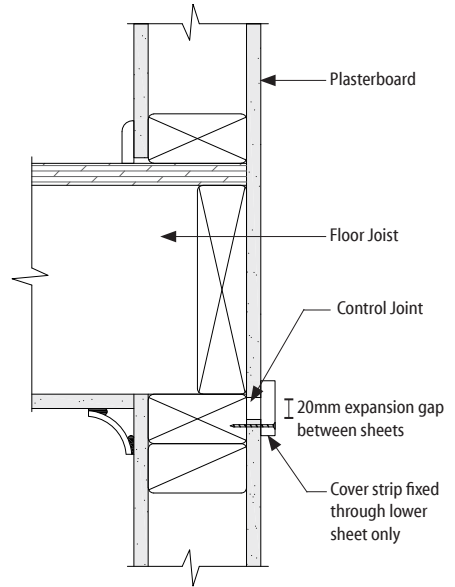

### Control Joints on Timber stud walls

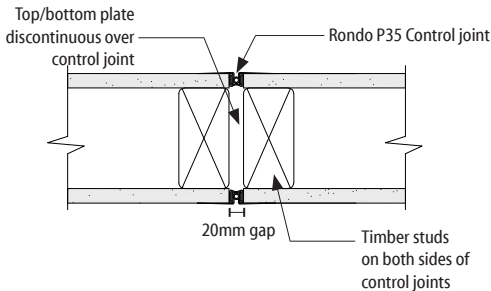
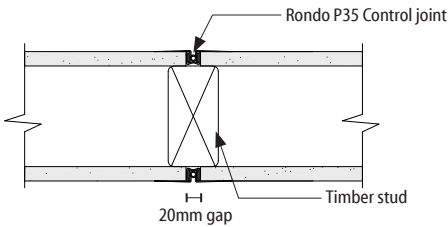

## GENERAL WALL AND CEILING INSTALLATION

### Concrete and Masonry Walls

#### General

For direct bonding of Elephant Plasterboard to concrete or masonry walls, the wall must be thoroughly dry, free of damp and be adequately protected from moisture penetration. Before commencing application a true plane must be established. Where irregularities occur use either plasterboard strips as packing, Timber strapping or Steel Furring channel.

- Apply adhesive 40mm from the sheet edges to avoid excess adhesive squeezing out through the joint.
- Ensure that sheets are applied within the setting time of the adhesive.
- All joints between sheets should be touch fitted.

#### Direct Bonding

- Masonry surface must be free of flaking paint, efflorescence, dust or any material that may impair the adhesive bonding.
- Apply daubs of adhesive at vertical and horizontal spacings of 300–400mm.
- Adhesive daubs should be approx 50mm in diameter and 10mm thick.
- Sheets should be firmly pressed into position ensuring full contact with adhesive. Hold sheets in position by shoring or other temporary fixing until adhesive has set.
- Cut Elephant Plasterboard sheets to allow a 10mm gap at the top.
- When adhesive has set remove shoring and carry out flush jointing.
- Control joints in walls must be carried through the plasterboard.

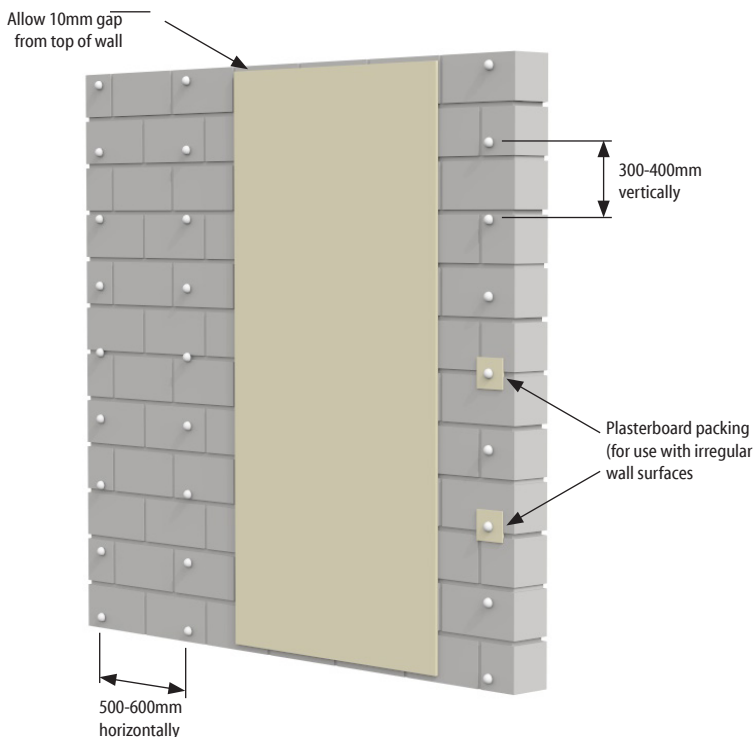



## GENERAL WALL AND CEILING INSTALLATION

### Concrete and Masonry Walls

#### Fixing Timber Strapping or Steel Furring Channel

- Fix timber strapping or steel furring channel vertically at 600mm centres with suitable fasteners and pack to achieve a true plane where necessary.
- Fix short lengths of timber strapping or steel furring channel at top and bottom leaving a 10mm ventilation gap between ends and main furring.
- Fixing details are as described for fixing Elephant Plasterboard to timber or steel frames.

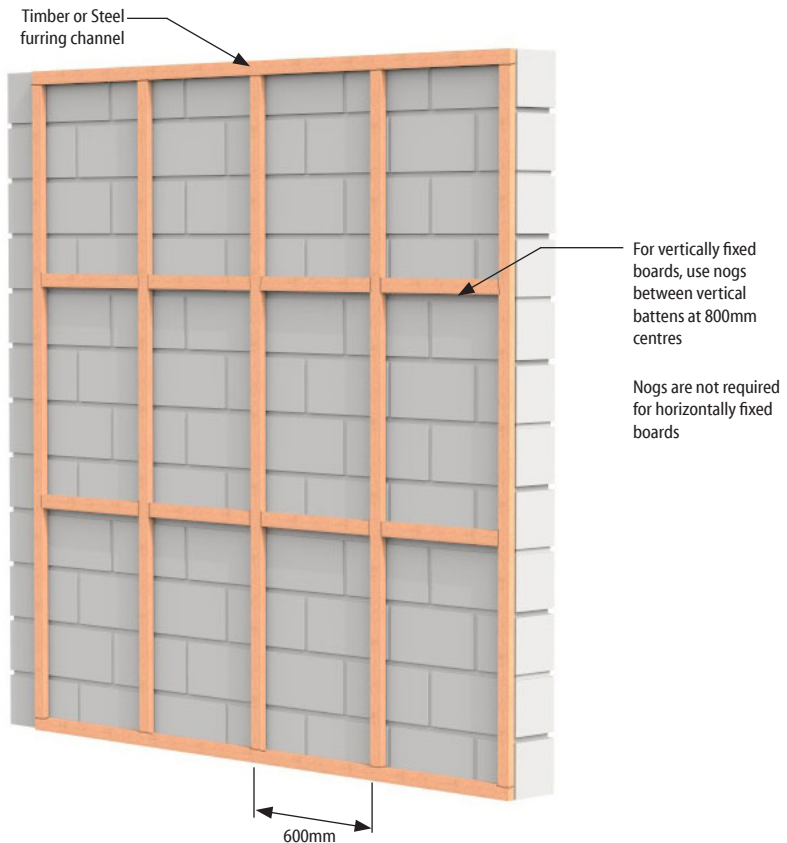

## JOINTING AND FINISHING

### General

Jointing and finishing of Elephant Plasterboard interior installations should be carried out according to the required level of finish, in accordance with the requirements of AS/NZS 2589:2017, to provide a smooth surface for decorating. A Level 4 Finish is generally the default level of finish for residential construction.

Elephant Plasterboard walls and ceilings must be jointed using compounds and reinforced with paper tape or corner beads. All joints, internal and external corners and fastener heads must be evenly finished with compounds and lightly sanded to remove tool marks and ridges prior to decoration.

This section covers the basics of joint construction and finishing.

### Jointing Materials

Jointing materials fall into two category, jointing tape and jointing compounds. Jointing compounds are either classified as setting compounds or air-drying compounds. The jointing system may consist of one or both the types of compounds and jointing tape.

#### Jointing Tape

Jointing tapes are used to provide reinforcement and resistance to joint cracking. A jointing tape aids smooth finishing and the roughened surface produces a superior bond to jointing compounds. The Jointing tapes provide strength and rigidity in the first coat of the three coat plasterboard jointing process. The tape is bedded in a base coat before the second coat and topping coat is applied and sanded ready for painting.

#### Jointing Compounds

##### Setting compounds

These compounds are plaster based, supplied in powder form and when combined with water in the recommended ratio, they set and harden by chemical reaction between the water and the plaster. Setting compounds are mainly used for bedding tape and base coating. They produce the strongest joints and reduce installation delays and shrinkage associated with air-drying type compounds. They can be applied with either hand or mechanical tools.

Setting compounds can be completely set but still damp in cold and humid conditions. In hot and dry conditions, rapid evaporation and increased absorption by the lining surface can prevent compound from setting correctly, making the compound to be soft and weak which in turn results in reduced strength and tape adhesion issues.

##### Air-Drying compounds

Air-Drying type compounds are premixed pastes that can be used for base and/or top coating. These compounds shrink and harden with evaporation of water. They are softer than the setting compounds and are designed for easy sanding. The joints must be allowed to set and appear completely dry before re-coating or sanding.

Air-drying compounds may require 24 hours drying time between coats, depending on weather conditions. In hot and dry conditions, these compounds reduces the risk of premature dry out associated with plaster-based setting compounds. In cold and humid conditions Air-Drying compounds may take longer to dry. Ventilation such as open windows or an exhaust fan may be required. Air-drying compounds must not be used when the interior temperature is lower than 10°C.

Do not use a Setting type compound over an Air-Drying compound.

### Storage

Jointing Compounds should be stored in a dry place above ground and protected from extreme temperature. Do not use the product after the expiry date as the performance of the product might be compromised.



## JOINTING AND FINISHING

### Preparation

At recessed joints ensure that all the screw or nail fixings are just below the plasterboard surface and not deep into the plasterboard which will cut the paper of the board, resulting in popping. Tidy up any damages on the plasterboard like broken corners. All surfaces must be free of any dust or foreign matter that could reduce bond.

### Mixing of Compounds

Proper mixing of the compound is the primary step to achieve good jointing.

- Always use clean water and clean containers, mixing equipment and tools for mixing. As using dirty containers/ water or tools might affect the setting time and setting strength.
- Never mix different compounds together or mix old batches with new ones as it could impair the performance of the compound.
- Use compounds before the 'best before' date on packaging.
- Follow the manufacturers mixing instructions printed on each bag.
- Mix by hand or power mixer until a smooth workable paste has been achieved.
- When using a power mixer, use a slow speed drill as higher speed could draw air into the mixture, creating air bubbles.

### Stopping of Recessed Joints - Hand Applied

#### Three Coat Application

##### First Coat (Tape Coat)

- Fill any gaps in joints with base compound prior to the taping process.
- Use a 150mm broad knife to evenly fill the joint recess formed by the tapered edges of the plasterboard with base compound.
- Centre and press the paper tape into the base compound using a 150mm broad knife, drawing along the joint with enough pressure to ensure that there are no air bubbles sandwiched beneath the tape.
- Leave sufficient compound under the tape to achieve a good bond.
- After embedding tape, immediately apply a skim coat of compound to reduce the possibility of the tape edge curling or wrinkling which can lead to edge cracking.
- Cover all fastener heads with compound.
- Allow the compound to set and dry.



First Coat - Bedding compound



First Coat - Taping



First Coat - Skim Coat



## JOINTING AND FINISHING

### Second Coat

- When the first coat has hardened and dried, apply a second coat of jointing compound with a trowel or broad knife.
- The second coat must be applied approximately 25mm beyond the edges of the first coat and feather the joint edges to eliminate compound build-up at the edges.
- Cover all fastener heads with a second coat of compound overlapping the first coat.
- Allow setting-type compounds to set completely, and drying type compounds to harden for 24 hours before proceeding.

### Finishing Coat

- When the second coat has hardened and dried, scrape back any build-up of compound along the joint to give a smooth and level surface.
- Using a trowel or a broad knife, apply a coat of finishing compound centrally over the previous coat.
- Feather the joint edges of the compound at least 25mm beyond the edges of the previous coat.
- Apply a finishing coat to all fastener heads and overlap the second coat by approximately 25mm.
- Allow a minimum of 24 hours to dry (longer in cold, wet weather conditions).
- When dry, lightly sand to a smooth finish with sanding mesh or 150-220 grit sandpaper in the same direction as the joint. Avoid any heavy pressure which might scuff the face paper of the plasterboard.

### Stopping of Butt Joints

- Butt or end joints that have been back-blocked should be flush-jointed and finished with a three coat system as for recessed joints.
- For a flatter finish and to minimise any apparent surface build-up of compound, widen each jointing coat so that the final coat of the finished joint is about 550mm to 600mm wide.
- All compounds should be applied in accordance with the compound manufacturer's instructions.
- For best results allow 24 hours between coats.



Second Coat



Finishing Coat



Sanding

## JOINTING AND FINISHING

### Stopping of Recessed Joints - with Mechanical Tools

#### Three Coat Application

##### First Coat (Tape Coat)

- Place and lock the jointing tape and pour the compound into the Banjo.
- Centre the joint tape along the joint and hold the tape in one hand while pulling the banjo on the other hand along the joint.
- Make sure the Banjo control knob is set such that approximately 2mm thick compound is squeezed out to the under side of the tape and nothing in excess.
- When the end of the joint is reached, neatly cut the tape with a broad knife.
- With the broad knife held approximately at 45 degrees to the board surface, press the tape down the compound along the joint with enough pressure to remove excess compound and any air bubbles sandwiched beneath the tape.
- Scrape back any ridges once the compound is set.



**Banjo Application**

##### Second Coat - with Flat box

- Automatic boxes distribute the correct amount of joint compound and feathers the edges over flat surfaces in one pass. They are usually 200mm or 250mm wide. All flat boxes have an adjustable setting that automatically crowns the joint for proper distribution of compound.
- After mixing the jointing compound to the right consistency fill the flat box with the compound.
- Placing the box flat over the surface, run along the joint to apply the second coat with the right pressure control.
- Scrape back any ridges once the compound is thoroughly dry and set.



**Flat Box Application**

##### Finishing Coat

- Mix the jointing compound to the right consistency such that it gives a smooth finish.
- Using a 300mm flat box, apply the top coat or the finishing coat to the joint.
- Allow compound to harden before proceeding.
- Use a power sander to smooth the compound.



## JOINTING AND FINISHING

### Internal and External Corners

#### Internal Corners — using Paper Faced Trims

- Apply bedding compound to both sides of the internal corner to be filled using a 75mm chamfered broad knife.
- Measure and cut the reinforcing tape, fold the paper tape along the centre line and bed into the compound using a 50mm.
- Using a broad knife wipe off excess compound under the tape to remove air bubbles. Ensure adequate amount of compound is left under the tape for good adhesion.
- Cover the tape with a thin coat of bedding compound and remove any excess and allow to set and dry.
- When dry apply a second coat of compound with the broad knife to both sides of the angle with a 100mm broad knife, feathering about 50mm beyond the edges of first coat.
- Allow a minimum 24 hours of drying time.
- When thoroughly dry, lightly sand for a smooth finish with sanding mesh or 150-220 grit sandpaper. Avoid any heavy pressure which might scuff the face paper of the plasterboard.

#### External Corners — using angle/corner bead

External corners should be strengthened with perforated metal angles/ corner beads then jointed and finished with a three coat system. Suitable metal angles include Rondo® Corner Beads P01 or P32, GIB® Slim Angle etc:

- Cut metal angle to length and position so that the angle is both straight and in line with the wall surfaces. Ensure that there is a 10mm gap left at the concrete floor to avoid rust.
- Mechanically fix the metal angle along each face with nails or staples at 100mm centres, working down from the top on alternative sides.
- Stop and finish with a three coat system as per jointing specification.
- Apply the first coat of bedding compound to both sides of the metal angle bead using a 150mm broad knife or 200mm trowel. Feather the edges and clean off the excess compound.
- Apply a second coat using a 200mm trowel. Allow compound to harden and dry and slightly sand back.
- Apply the third and final coat of compound using a 300mm trowel. Allow compound to harden and dry and slightly sand back to a smooth finish.

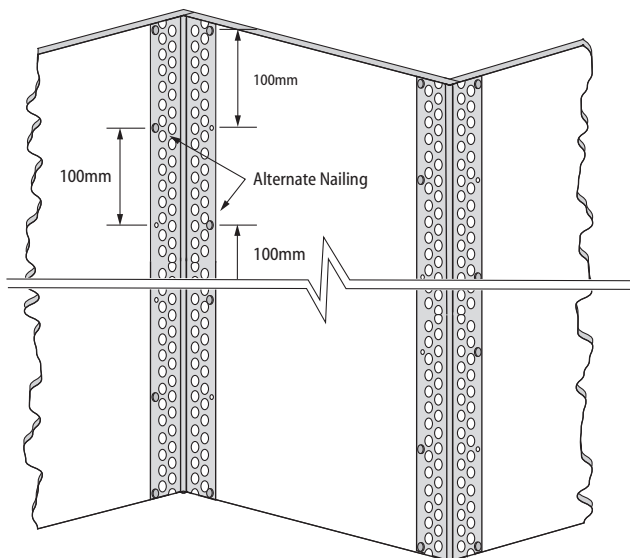

## JOINTING AND FINISHING

### Cornice Installation

Cornice is designed to complete the junction of the wall and ceiling and provide a decorative finish. Cornice is fixed to walls and ceiling using cornice cements, which are chemical setting compounds available in powder form.

#### Preparation

- Ensure that the wall and ceiling surfaces are free of dust.
- For accurate level placement of cornice, mark ceiling and walls with a line from the wall/ceiling angle.
- Measure and cut all cornices to the required length using a fine-toothed saw or mitre box and sand the edges.
- Avoid joints in straight runs where possible, if necessary, mitre the joints and do not square cut.
- Mix cornice adhesive as per the manufacturer's instruction.

#### Installation

- Apply minimum 10mm of cornice adhesive along both back edges and the mitres end of the cornice.
- Position the cornice accurately in the marked position and press firmly into the cement. If necessary, hold the cornice in place with temporary nails in the wall and ceiling along the edges of the cornice.
- Remove any excess adhesive and clean off the residue with damp brush or sponge.
- Allow the adhesive to set and remove nails and fill the holes.

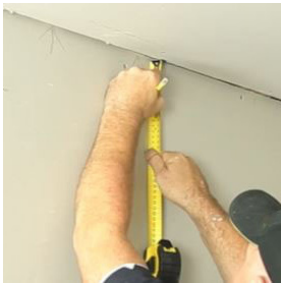

1. Marking Ceiling and Walls

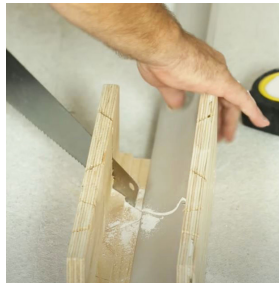

2. Cutting Cornice to measurement



3. Apply Cornice adhesive



4. Position the cornice



5. Clean off the excess

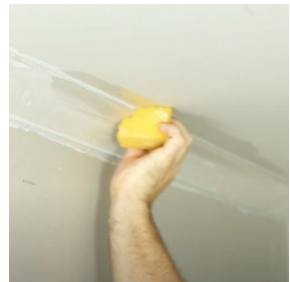

6. Wipe down with damp sponge



## JOINTING AND FINISHING

### Decoration

#### General

Elephant Plasterboard surfaces provide an excellent base to be decorated in any variety of finishes including flat, semi-gloss or gloss paint, wallpaper or special finishes.

The use of satin and high gloss paints can at times highlight surface imperfections, hence it is recommended that plasterboard surface is finished to a Level 5 standard. When these paint finishes are required it is important that an even texture is achieved over the entire plasterboard surface. No building material has an absolutely flat surface, and all that can be achieved in practice is the appearance of flatness. Guidance for a finished plasterboard surface with even texture and appearance of flatness in preparation for painting is provided in AS/NZS 2589:2017 - Gypsum linings - Application & Finishing.

When preparing surfaces and applying decorative finishes, it is important that all materials be used strictly in accordance with the manufacturer's instructions.

#### Surface Preparation

- Ensure Elephant Plasterboard surface is dry, remove all loose dirt, dust, oil or stain with a soft brush or dry cloth.
- All joint stoppings must be sanded smoothly.
- Surface imperfections should be made good with an approved filler.

#### Sealer Undercoat

A quality sealer undercoat is to be applied prior to application of coats of paint.

- When applying sealers and primers, apply sufficient quantities to ensure that the surface is completely covered.
- Do not overwork or over roll the first coat as this may cause the paint to lift over the jointed areas.
- Brush or roller application of sealers is recommended to obtain the best results as this ensures adequate binding over the jointed areas.
- Allow the undercoat to dry and lightly sand with fine to medium grade paper before applying subsequent coats of paint.

#### Top Coats

- Under normal conditions, allow 12 to 18 hours after the application of sealers before applying the subsequent coats of paint. In rainy, humid or cold weather conditions a waiting period of up to 36 to 48 hours may be required before re coating.
- For the best results apply the final coat with a roller which will ensure a full cover coat and a uniform texture over the entire surface.
- Cut in around edges with a brush and apply paint to the broader areas with 10mm nap synthetic roller which gives a slight texture that improves the overall evenness of finish.
- Ensure each coat is dry and follow manufacturer's instruction on re coat timings before applying the next coat.
- When paint is applied by airless spray paint, then it is essential that back rolling occurs when the paint is still wet, otherwise resulting in excessive paper nap raising.
- Plasterboard that has been fixed and allowed to stand for a long periods prior to painting may discolour due to exposure to light. This should be well sealed with an approved oil based sealer before the application of the finishing coats of paint.
- Oil or solvent based paints are recommended in areas of high humidity, or where water resistance and 'cleanability' are important, such as bathrooms, kitchens, laundries and toilets.





## REPAIRS & MAINTENANCE

---

### Accidental Damage

#### Fire

After an outbreak of fire the paper face, core and joints must be checked and where the paper face or the core of any sheet has been affected then the whole sheet must be removed and replaced.

#### Bracing

After a severe earthquake and extreme wind conditions, the Bracing elements must be checked for cracks at joints, deformation of sheet or joints and damage to the fixing/sheet sealing.

Where the damage is minor, for example, limited nail pops or joint cracks, the item should be made good as soon as practicable. Where the damage is severe, for example, board distortions and fixing failure, then the whole sheet must be re-nailed or replaced and advice sought from a consultant engineer.

#### Flooding

After a flood or when severe moisture ingress has occurred, all Elephant Plasterboard Systems should be inspected by a suitably qualified person. Certain components of the system may need to be replaced and in this instance we recommend that advice is sought from the manufacturer's agent.

#### Direct Impact

If the integrity of the Elephant Plasterboard Drywall System is affected then the area up to the nearest stud or nog must be cut out and made good with new Elephant Plasterboard, including jointing.



## REPAIRS & MAINTENANCE

---

### Repairing Damaged Plasterboard

Plasterboard can be damaged due to a number of reasons like cracks, dents, scratches or holes. These damages can be repaired by following these set of instructions below. Note that these instructions are not suitable for repairing fire rated walls or ceilings.

#### Patching Dents, voids, holes, popped nails and cracks

- To repair a dent:
  - Sand the area and fill it with jointing compound using a broad knife.
  - Let the compound dry and harden.
  - Add second coat if necessary. Sand and prime when dry.
- To repair a small hole or crack:
  - Trim any loose pieces from the damaged area and wipe it clean.
  - Fill the area with jointing compound and let it dry and harden.
  - Add second coat if necessary. Sand and prime when dry.
- To repair screw popping/nail pops:
  - Drive a new screw 50mm from the popped screw.
  - Push the popped screw beneath the plasterboard surface using a nail punch.
  - Cover the area with two coats of jointing compound. Sand and prime when dry.
- To repair bubbles in jointing tape:
  - Cut open the area where the bubbles appeared.
  - Fill the area with jointing compound and press back firmly with broad knife and let it dry.
  - Sand and smooth to level finish.

#### Patching Medium to Large holes

- For holes up to 150mm in diameter, a plasterboard patch is required.
- Trim and cut any loose pieces from the damaged area into a neat hole using a knife.
- Sand the area around and wipe it clean for good adhesion.
- Cut a small piece of plasterboard 20mm longer than the hole and place a 60mm flat head nail right in the centre of the cut piece and cover the ends with jointing compound.
- Insert the cut piece into the hole and pull it to the front using the nail and let it dry. Once its dry, push the nail back through the patch gently.
- Cut another piece of plasterboard to fit the existing hole and position it in place.
- Patch up the hole using jointing compound over the joints.
- Apply jointing tape over the four edges and once the first coat of compound dries and hardens, apply a second coat and feather the edges and let it dry for minimum 24 hours.
- Apply a finishing coat and let it dry. Sand and prime when dry.
- These set of instructions are not applicable for fire rated walls.



Visit [www.elephantplasterboard.co.nz](http://www.elephantplasterboard.co.nz) for the latest product information and Technical manuals and CAD drawings.

## Customer Services

### Free Help line

0800 ELEPHANT (353-742)

### Email

[info@elephantplasterboard.co.nz](mailto:info@elephantplasterboard.co.nz)

### Website

[www.elephantplasterboard.co.nz](http://www.elephantplasterboard.co.nz)

### Telephone

(09) 818-7706

Elephant Plasterboard (NZ) Limited  
P.O. Box 21-436, Waitakere 0650  
New Zealand

Exceeds the New Zealand and Australian Standard.  
AS/NZ 2588  
Manufactured to ISO 9001 International  
Organisation for Standardisation





**Elephant**  
Plasterboard

STRENGTH WITH STYLE

FOR MORE INFORMATION

---

EMAIL [info@elephantplasterboard.co.nz](mailto:info@elephantplasterboard.co.nz)

CALL 0800 ELEPHANT (353 742)