

PRODUCT INFORMATION & TECHNICAL SPECIFICATION

elitewardrobes.au

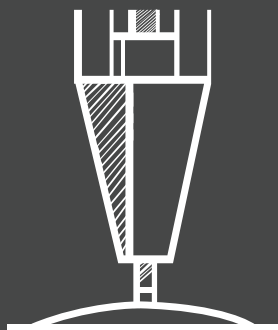

ELITE
WARDROBES
BY THE WARDROBE MAN 

INTRODUCING THE ELITE SHELVING SYSTEM

Unmatched craftsmanship, style and functionality.

Elite Wardrobes by The Wardrobe Man offers a unique, customisable alternative to traditional wardrobes and shelving. By blending expert craftsmanship with modern flexibility, we've helped hundreds of Australians transform their spaces with elegant, functional designs. Whether you need a walk-in wardrobe, custom home office, or living room shelving, our clients include homeowners, architects, builders, and designers. We're ready to create the perfect solution for you too



A modern wardrobe with a wooden shelf at the top, a hanging rack with five clothes, and shelves with a hat and two handbags. The clothes are a beige coat, a striped shirt, a white lace top, a brown coat, and a grey coat. The handbags are a white one and a brown one. The text "ELITE COMPONENTS & TECHNICAL SPECIFICATION" is overlaid in the center.

ELITE COMPONENTS & TECHNICAL SPECIFICATION

ELITE FLOOR TO WALL POST 2310MM

[SKU:PT-BLACK, PT-ASH]

Finish Options: Black or Ash

The Elite Floor-to-wall Post is the main structural element in building wardrobes, walk-in robes, and shelving systems. It allows for easy adjustment of wardrobe components to maximize space efficiently.

Specifications:

- **Height:** 2310mm (with foot and top elbow attached, 2400mm)
- **Material:** High-grade aluminium
- **Features:** Adjustable foot, top elbow for wall installation, LED lighting capability

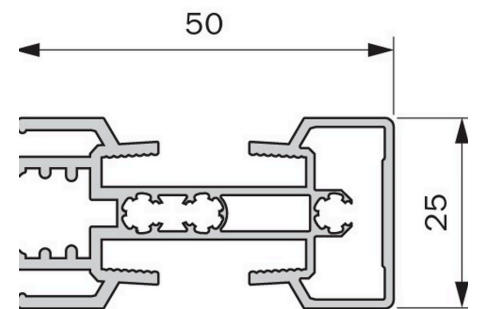

ELITE ADJUSTABLE FOOT 90MM

[SKU:FT-BLACK, FT-ASH]

Finish Options: Black or Ash

The Adjustable Foot is a critical component of the Elite Modular Wardrobe System, providing a stable base for the posts. It allows for height adjustment to ensure level installation on uneven floors.

Specifications:

- **Height:** 90mm, adjustable
- **Installation:** Attached to the post using a supplied screw
- **Material:** High-grade aluminium
- **Finish:** Available in Black or Ash

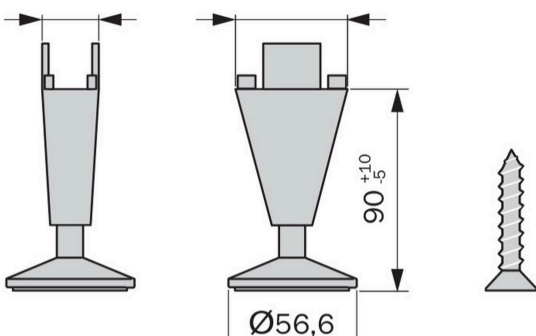

TOP ELBOW FOR WALL INSTALLATION

[SKU:EW295-BLACK,EW295-ASH]

Finish Options: Black or Ash

The Top of Post Elbow is an essential component for securing the Elite Modular Post to the wall, ensuring stability and strength for your wardrobe or shelving system.

Specifications:

- **Length:** 295mm
- **Material:** High-grade aluminium
- **Installation:**
 - **Attachment to Post:** The top Elbow is attached to the post using a unique blue block that locks into the side of the post. The Elbow is then pushed over the blue block and screwed into the top of the post, ensuring a secure fixing.
 - **Wall Fixing:** The Italian fixing system includes a second blue block that is fixed to the wall. Once securely attached to the wall, the Elbow is fixed to the blue block, ensuring stability.
- **Elbow Kit Components:**
 - Elbow
 - Two Blue Blocks (one for fixing to the wall and one for fixing to the top of the post)
 - 8mm Wall Plug for Brick Walls
 - All Screws for Fixing to the post and wall

The Top of Post Elbow is designed to seamlessly integrate with the other components of the Elite Modular Wardrobe System, ensuring a cohesive and sturdy installation. This element is especially important for achieving a robust and reliable structure, capable of supporting various wardrobe and shelving configurations.

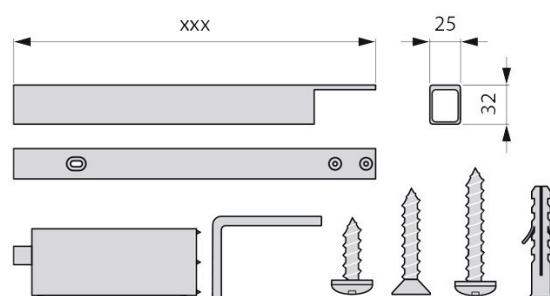





ELITE LED LIGHTING KIT

[SKU:DL-BLACK, DL-ASH]

The LED Lighting KIT for Elite Modular Structure is a sophisticated and practical component designed to enhance the aesthetics and functionality of your modular wardrobe system. It offers a modern touch to any environment, making it ideal for both commercial and residential spaces.

Specifications:

- **Material:** High-grade aluminium with LED integration
- **Function:** Provides elegant lighting to enhance visibility and ambiance within the wardrobe or shelving unit

Installation:

- **Attachment to Structure:** The LED Kit is designed to integrate seamlessly with the Elite modular structures. It can be easily fixed to the posts using the included mounting brackets and hardware.
- **Power Source:** The LED system includes wiring that can be discreetly run through the back of the structure, ensuring a clean and professional installation.

Applications:

- **Versatile Use:** The LED Lighting Kit for Elite Structure is perfect for various environments. It can be used as an open wardrobe in a bedroom, a custom bookshelf and room divider in a living room, or an organizing unit in kitchens and bathrooms.
- **Ease of Integration:** The modular design allows for easy combination with other elements, creating tailored compositions without the need for complex installations.

Elite LED Lighting Kit Components:

- The LED Lighting Strip (custom lengths available)
- Mounting Brackets and Hardware
- Wiring for LED Integration

The LED Lighting Kit for Elite Structure not only adds a luxurious lighting element to your space but also enhances the functionality and appeal of your modular system. It ensures that your wardrobe or shelving unit is not only stylish but also practical and well-lit, making it a standout feature in any room.

ELITE DRAWER BOX LARGE FIXING BRACKETS

[SKU:DBBL-BLACK, DBBL-ASH]

Finish Options: Black or Ash

The Large Fixing Brackets are essential for supporting drawer boxes within the Elite Modular Wardrobe and Shelving System. These brackets are designed to provide robust support for heavy items, ensuring stability and functionality.

Specifications:

- **Dimensions:** 240mm (length)
- **Material:** High-grade aluminium
- **Features:** Double Fixing System ensures enhanced stability and support

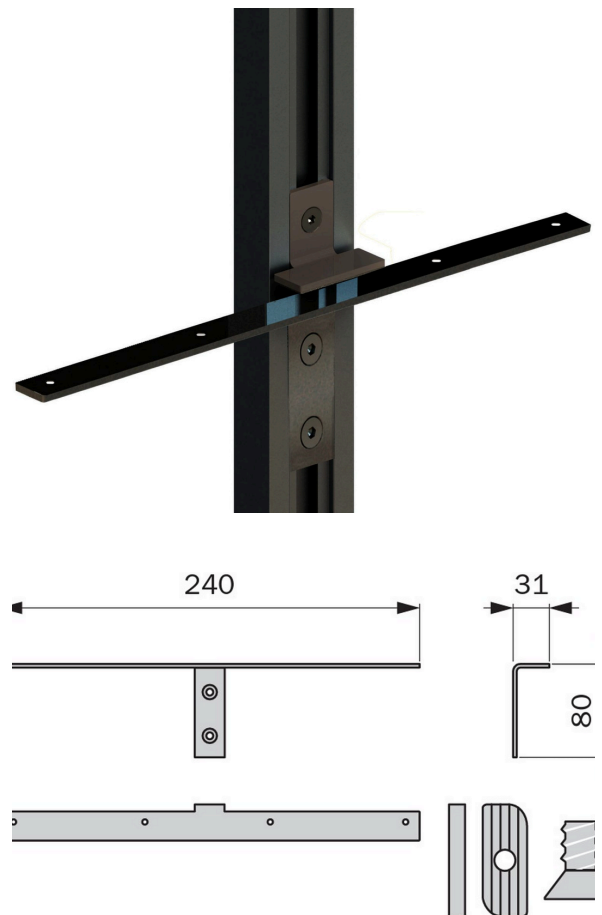

Installation:

- **Adjustment:** A 4mm Allen Key is used to adjust the brackets and secure the drawer boxes in place.
- **Leveling:** After installation, use a spirit level between the two brackets to ensure the drawer box is level.
- **Bracket Pair:** Brackets are sold as a pair, as two are required per drawer box.

Application:

- **Supports:** Single Drawer, Double Drawer Box, Triple Drawer Box, and heavy items like Flip Up or Flip Down Cabinets.
- **Fixing to Wall:**
 - **Brick Walls:** Use the 8mm wall plugs and screws provided for a secure fix.
 - **Plasterboard:** Ensure the box is screwed into the wall studs for stability.

Drawer Box Fixing Kit Components:

- Two Large Fixing Brackets
- 8mm Wall Plugs for Brick Walls
- Screws for Fixing to the Post and Wall

The Elite Large Fixing Brackets provide the necessary support for drawer boxes and other heavy items, ensuring your wardrobe system is both stable and functional. With easy adjustment and secure installation, these brackets are a crucial component for creating a reliable and stylish storage solution.



ELITE TIMBER SHELF BRACKET FOR TIMBER SHELVES 160MM

[SKU:TSB-BLACK, TSB-ASH]

The Elite Timber Shelf Brackets are a versatile and essential component of the Elite Modular Wardrobe and Shelving System. These brackets provide robust support for various shelving needs and can be easily adjusted for maximum flexibility.

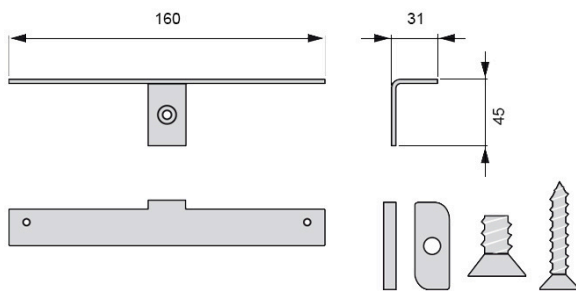

Specifications:

- **Dimensions:** 160mm in length
- **Material:** High-grade aluminium with LED integration
- **Finish:** Available in Black or Ash

Installation:

- **Adjustment:** A 4mm Allen Key is used to adjust the brackets and secure the shelves in place.
- **Bracket Pair:** Brackets are sold as a pair, as two are required per shelf.

Application:

Supports:

- 25mm thick shelves, typically 500mm deep
- Gliding Shoe Racks, 500mm deep
- Trousers Racks

Positioning: The brackets can be positioned and repositioned at any point on the post system, allowing for easy reconfiguration as storage needs change. Allows for precise adjustment and positioning on the post system.

Elite Wooden Shelf Support Set:

- **Components:** Includes screw and vertical bar fixing element.
- **Versatility:** Can be integrated into multiple environments, such as:
 - Exposed dressing room in a bedroom
 - Custom-made shelf and room divider in a living room
 - Commercial Shelving in commercial areas such as shops and offices or in residential areas.

ELITE FIXING BRACKET FOR ANGLED TIMBER SHELVES 160MM

[SKU:ASB-BLACK, ASB-ASH]

Finish Options: Black or Ash

Ideal for shoe storage, the Angled Shelf Bracket can be positioned and adjusted easily for optimal organisation.

Specifications:

- **Length:** 160mm
- **Material:** High-grade aluminium
- **Installation:** Adjustable with a 4mm Allen key; sold as a pair

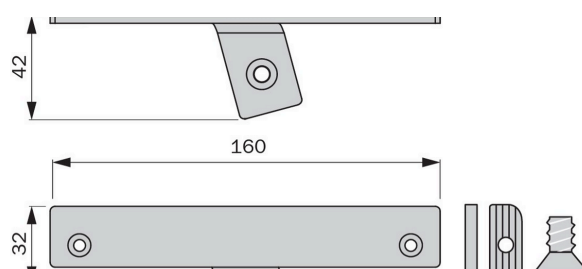

ELITE FIXING BRACKET FOR GLASS SHELVES

[SKU:GSB-BLACK, GSB-ASH]

Finish Options: Black or Ash

The Fixing Bracket for Glass Shelves allows for elegant display and storage solutions.

Specifications:

- **Material:** High-grade aluminium
- **Installation:** Adjustable with a 4mm Allen key; sold as a pack of four
- **Glass Specifications:** 6mm safety glass with polished edges

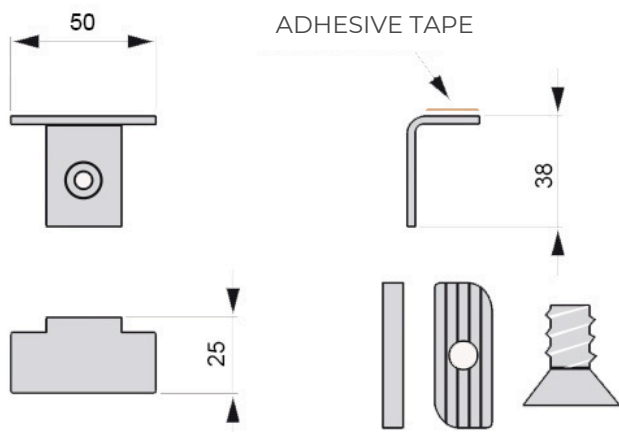

ELITE CEILING MOUNT FOR UPRIGHT

[SKU:SM-BLACK, SM-ASH]

Finish Options: Black or Ash

The Ceiling Mount for Upright is designed to provide secure and stable ceiling fixation for the Elite Modular Wardrobe system. This kit ensures that the upright posts are firmly anchored to the ceiling, offering maximum support and stability for your wardrobe or shelving system.

Specifications:

- **Length:** 90mm
- **Material:** High-grade aluminium
- **Installation:** Comes with a ceiling fixation screw to attach the Adjustable foot and the connection elements together

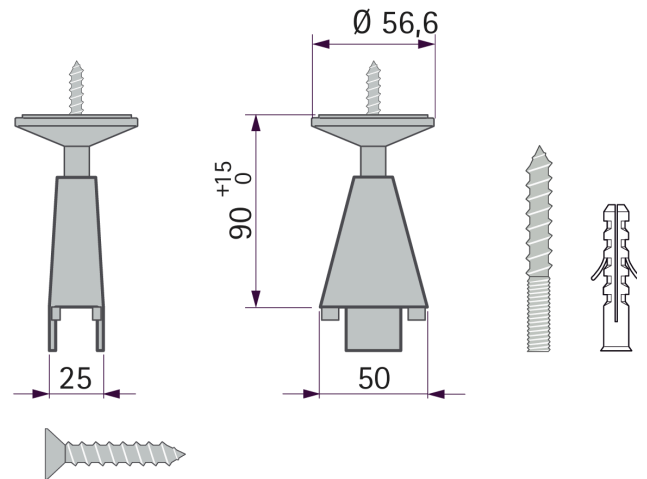

ELITE HANGER BARS WITH BRACKETS 900MM

[SKU:HB]

Finish Options: Black or Ash

The Hanger Bar is designed for flexibility, allowing it to be cut to any length and easily repositioned.

Specifications:

- **Width:** 900mm; can be cut to smaller size
- **Material:** High-grade aluminium
- **Features:** Unique rubber cushion for added protection
- **Installation:** Adjustable with a 4mm Allen key; includes two hanger bar brackets

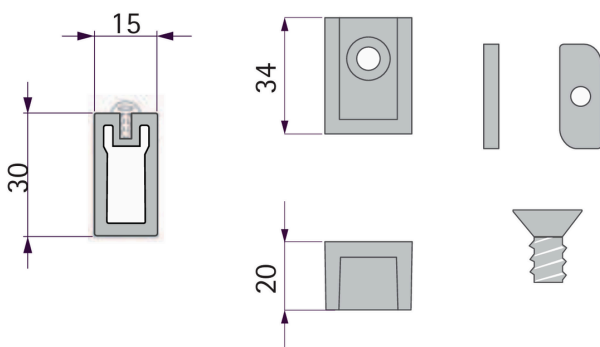





ELITE GLASS SHELF WITH ALUMINIUM FRAME

[SKU:FGS-BLACK, FGS-ASH]

The Elite Framed Glass Shelf is a sophisticated and functional addition to any wardrobe or shelving system. Designed with a high-grade aluminium frame and extra transparent glass, this shelf combines durability with an elegant, modern aesthetic. Ideal for residential as well as commercial spaces.

Specifications:

- **Dimensions:** 600mm (length)x 450mm (depth)
- **Material:** High-grade aluminium, and extra transparent glass
- **Finish:** Available in Black or Ash

ELITE FRAMELESS GLASS SHELF

[SKU:GS]

The Elite Frameless Glass Shelf is designed to beautifully display handbags, perfumes, and other decorative items. Made from toughened safety glass, these shelves are not only aesthetically pleasing but also built to last. Each glass shelf is custom-cut to size, with polished edges for a smooth finish and then toughened to ensure maximum strength and safety.

Specifications:

- **Length:** 450mm-850mm(length), 350-500mm(depth), 6mm(thickness)
- **Material:** Toughened Safety Glass
- **Features:** 4-5 times stronger than standard glass; Polished Edges; Manufactured to Australian Standards, ensuring quality and safety





ELITE TIMBER SHELF

[SKU:SH]

The 25mm shelves for the Elite Wardrobes shelving system are designed for versatility and customization. Available in a variety of colours and finishes, these shelves can be tailored to match your existing decor and personal style. Manufactured using high-quality materials from Laminex and Polytec, two of Australia's leading suppliers, these shelves offer durability and aesthetic appeal.

Specifications:

- **Thickness:** 25mm
- **Material:** High-quality Laminex and Polytec
- **Standard Widths:** 850mm, 800mm, 750mm, 700mm, 650mm, 600mm
- **Installation:** Attach to the posts using Elite Shelf Brackets. The height of the shelves can be easily adjusted to meet changing storage needs.

ELITE PANT RACK

[SKU:TR]

The Elite Trouser Racks offer a smart space-saving solution by optimizing vertical wardrobe space. Designed to efficiently organize trousers, these racks ensure easy access and wrinkle-free storage. Seamlessly integrating with the Elite Wardrobes wardrobe system, these racks enhance both the appearance and utility of your wardrobe, offering a perfect blend of style and practicality.

Specifications:

- **Height:** 155mm
- **Depth:** 500mm
- **Standard Widths:** 800mm, 750mm, 700mm, 650mm, 600mm
- **Materials:** Manufactured from 25mm thick boards, available in any of our standard finishes.







ELITE SINGLE DRAWER BOX UNIT

[SKU:1DB]

The Elite Single Drawer Box unit is ideal for a dressing table or enclosed storage in a small space. The height of this drawer unit is ideal for storing smaller accessories like jewellery, makeup, ties or lingerie.

Specifications:

- **Height:** 213mm
- **Depth:** 550mm
- **Standard Widths:** 850mm, 800mm, 750mm, 700mm, 650mm, 600mm

Drawer Runner Options:

1. Blum Legrabox Push to Open:
2. Hafele Alto Slim:

Installation:

- **Mounting:** Sits on the Elite Shelf Bracket
- **Safety:** Must be fixed to the back wall to avoid tipping hazard



ELITE 2 DRAWER BOX UNIT

[SKU:2DB]

The Elite 2-Drawer Box elegantly combines style and functionality, offering a vital storage solution in our space-conscious world. With two spacious drawers, it effortlessly restores order and promotes a clutter-free living environment. Engineered for quiet and smooth operation, these drawers close silently with a gentle push, maintaining a peaceful ambiance in your space. This 2-drawer unit proves that elegance and practicality can coexist beautifully in your home, making a statement about your commitment to an organized and serene living space.

Specifications:

- **Height:** 401mm
- **Depth:** 550mm
- **Standard Widths:** 850mm, 800mm, 750mm, 700mm, 650mm, 600mm

Drawer Runner Options:

- Blum Legrabox Push to Open:
- Hafele Alto Slim:

Installation:

- **Mounting:** Sits on the Elite Shelf Bracket
- **Safety:** Must be fixed to the back wall to avoid tipping hazard



ELITE 3 DRAWER BOX UNIT

[SKU:3DB]

The Elite 3-Drawer Box is a versatile storage solution that combines elegance with practicality. In a world where space optimization and organization are paramount, this drawer box stands out as an essential addition to your storage solution. With three spacious drawers, it brings order to chaos, offering a clutter-free living experience.

Specifications:

- **Height:** 589mm
- **Depth:** 550mm
- **Standard Widths:** 850mm, 800mm, 750mm, 700mm, 650mm, 600mm
- **Options:** Available with a base (for desking) or without

Drawer Runner Options:

1. Blum Legrabox Push to Open:
2. Hafele Alto Slim:

Installation:

- **Mounting:** Sits on the Elite Shelf Bracket
- **Safety:** Must be fixed to the back wall to avoid tipping hazard



ELITE 4 DRAWER BOX UNIT

[SKU:4DB]

The Elite 4-Drawer Box is meticulously designed to sit exactly at 1000mm high, making it a perfect storage solution that works as a unit that sits on the floor and acts as a platform under a half hang or other shelves. This unit features three standard drawers and one large tub drawer at the bottom, providing ample space for storing large and bulky items such as jumpers. Due to its weight, the 4-Drawer Box sits securely on the floor with four adjustable feet and must be fixed to the back wall for safety. This unit can be customized with either push-to-open mechanisms or handles, depending on the drawer runner option chosen.

Specifications:

- **Height:** 1000mm
- **Depth:** 550mm
- **Standard Widths:** 850mm, 800mm, 750mm, 700mm, 650mm, 600mm
- **Options:** Available with a base (for desking) or without

- **Drawer Details:**
 - Top 3 Drawers:
 - Drawer Front Height: 185mm
 - Runner System: Blum Legrabox Height K (128.5 mm)
 - Bottom Drawer:
 - Drawer Front Height: 308mm
 - Runner System: Blum Legrabox Height C (177.5 mm)







ELITE FLIP CABINET

[SKU:FC]

The Elite Flip Up Cabinet is expertly tailored for home offices, providing an efficient and elegant way to organize items and files that do not require constant display. This cabinet seamlessly integrates into your Elite Wardrobes setup, ensuring a tidy and cohesive environment. Designed with practicality in mind, the Elite Flip Up Cabinet can be installed at any height, ensuring it remains within comfortable reach for convenient access.

With its versatile design, the Elite Flip Up Cabinet offers a flexible storage solution, catering to specific storage needs while enhancing the visual appeal of your workspace. Embrace the convenience of tidily storing essentials and enjoy the cohesive aesthetic of this thoughtfully designed storage solution.

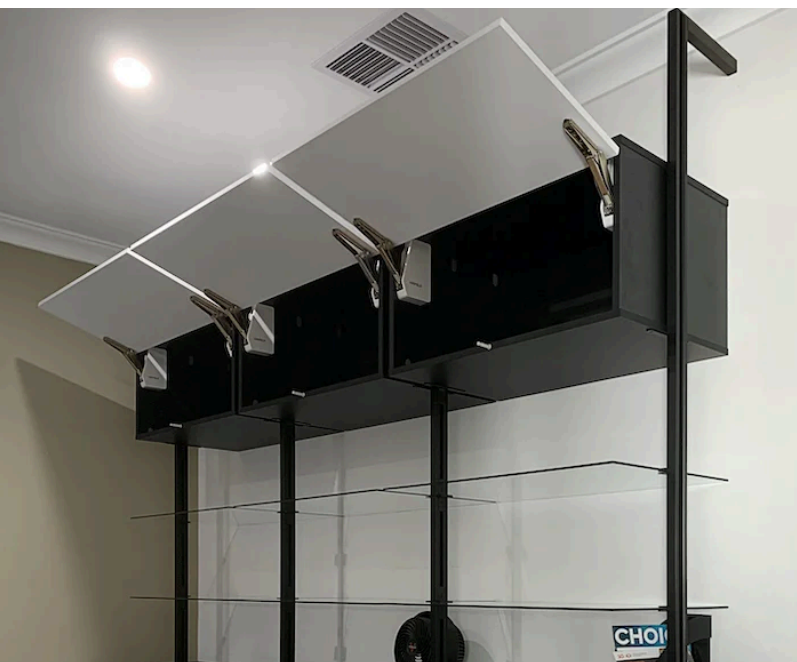

Specifications:

- **Height:** 401mm
- **Depth:** 550mm
- **Standard Widths:** 850mm, 800mm, 750mm, 700mm, 650mm, 600mm

Door Options:

- Single Flip Up Cabinet with Handle
- Optional Push to Open Mechanism

Hinges:

- System: Hafele Free Flap System

Installation:

- **Mounting:** Sits on the Elite Shelf Bracket
- **Safety:** Must be fixed to the back wall to avoid tipping hazards



ELITE TWO DOOR CABINET

[SKU:TB]

Elite Two Door Cabinet is ideal for overhead enclosed storage. The cabinet can be used with or without handles. Whether it's for a wardrobe, living room shelving or home office shelving, the two door cabinet works perfect for storing large items that cannot fit in a narrow drawer.

- **Height:** 401mm
- **Depth:** 350mm
- **Standard Widths:** 850mm, 800mm, 750mm, 700mm, 650mm, 600mm





ELITE JEWELLERY ORGANISER DISPLAY

[SKU:JO]

Enhance your wardrobe with the Elite Jewellery Organiser Display Upgrade, a blend of style and functionality designed to elevate your storage solutions. This upgrade provides a dedicated space for organizing and showcasing your jewellery collection, transforming your walk-in wardrobe into a luxurious haven.

The Elite Wardrobes Jewellery Organiser features a meticulously crafted Drawer Top with a purposeful cut-out, offering an elegant display solution for your treasured items. The internal surface is adorned with 1mm Black edging, hand-edged and trimmed to perfection, showcasing Elite Wardrobes's commitment to excellence.

Designed for durability and luxury, the Velvet Lined Drawer boasts Carbon Black Sides and Back, providing a soft and protective environment for your jewellery. Opt for the optional Glass Top to add sophistication and visibility to the cutout drawer.

Width Options: 850mm to 700mm
(customizable)

Drawer Frame Material: Carbon black steel

Interior Lining: Soft velvet lining

Edging: 1mm Black hand-edged and trimmed

Features:

- Interior Design:
 - Velvet Lined Drawer with Carbon Black Sides and Back
- Optional Accessories:
 - Optional Glass Top for enhanced visibility
 - Optional Jewellery Tray for customized organization





ELITE GLIDING SHOE SHELF

[SKU:SR]

The Elite's Gliding Shoe Shelf seamlessly blends functionality and elegance. Thoughtfully designed by our expert designers, this shelf optimizes shoe storage while adding a touch of sophistication to your wardrobe. With full extension capabilities, the gliding shoe shelf offers ample space and easy access to your shoe collection.

Specifications:

Height: 130mm

Runner: Blum Movento - This concealed runner system, manufactured in Austria, offers a synchronised feather-light glide for an ultra-smooth running action. Comes with a Lifetime Warranty.

Installation: Sits on the Elite Shelf Bracket and must be fixed to the back wall to avoid tipping hazards.

Standard Widths: 850mm, 800mm, 750mm, 700mm, 650mm, 600mm

Features:

- Full Extension Gliding: The shoe shelf extends fully, providing effortless access to your entire shoe collection.
- Chrome Fence System: Ensures smooth sliding of shoes, enhancing the ease of use and accessibility.
- Adjustable Height: The shelf can be adjusted to various heights on the post, allowing customization based on your storage needs.



ELITE ANGLED SHOE SHELF

[SKU:AS]

The Elite's Angled Shoe Shelf is ideal for having a shoe display for easy access and visibility.

Specifications:

Height: 200mm

Standard Depths: 350mm, 400mm, 500mm

Installation: Sits on the Elite Angled Shelf Bracket and must be fixed to the back wall for stability.

Standard Widths: 850mm, 800mm, 750mm, 700mm, 650mm, 600mm

Features:

- **Chrome Fence System:** Ensures smooth sliding of shoes, enhancing the ease of use and accessibility.
- **Adjustable Height:** The shelf can be adjusted to various heights on the post, allowing customization based on your storage needs.

Installation Tips:

- Position the shelf below waist height for convenient access.
- Ensure there is adequate clearance for different shoe sizes.





ELITE PULLOUT PIVOT MIRROR

[SKU:PM]

Maximize your space and enhance your wardrobe functionality with our Pull Out Pivot Mirror. Designed for bedrooms and wardrobes where space optimization is crucial, this innovative mirror combines convenience with style.

Specifications:

Height: 889 mm, 1203 mm

Standard Widths: 33mm, 38mm

Pivot Capacity: Extends 151 mm from the front edge of the closet, allowing up to 345° rotation

Material: Aluminum

Features:

- **Easy Operation:** Features an integral full-length bright anodised aluminium profile handle, allowing you to easily pull out and pivot the mirror for a full view.
- **Smooth Mechanics:** Equipped with full extension ball bearing galvanized steel runners, ensuring a smooth pull-out motion.
- **Stable Viewing:** Slides have detents in and out to hold the mirror securely in place, providing stable viewing.
- **Versatile Installation:** Ideal for spaces where the mirror needs to be mounted on the outside of a panel and rotated inwards. The installation requires just four screws, making it straightforward and efficient.





ELITE FINISHES

DRAWER BOXES AND SHELVES

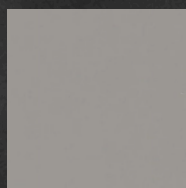

Tornado Flint

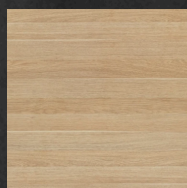

Classic Oak



Fox
Teakwood



Bottega Oak
Woodmatt



Florentine
Woodmatt

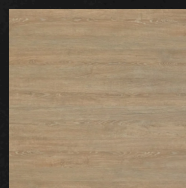

Rural Oak

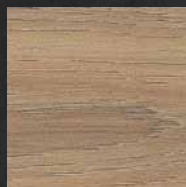

Prime Oak

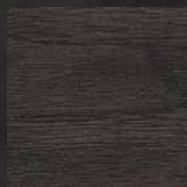

Perugian
Walnut

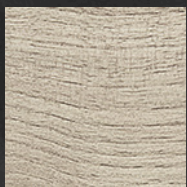

Ligurian
Walnut

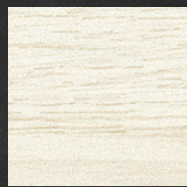

Whitewood



Palomera Oak

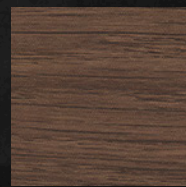

Rubra Oak

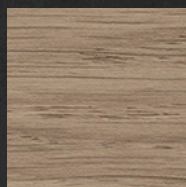

Manor Oak

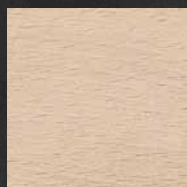

Nordic Oak



Rojo Walnut



Havana Oak

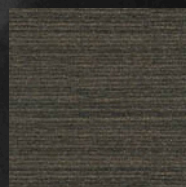

Truffle Lini

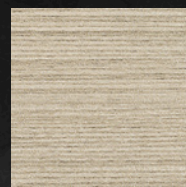

Gesso Lini

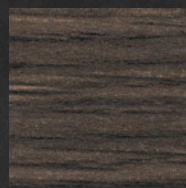

Belgian Oak



Maroso Milan



Combat Teak

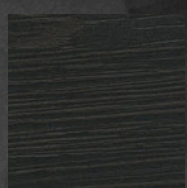

Black Wenge

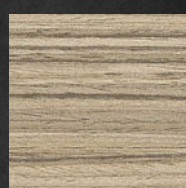

Satra Wood

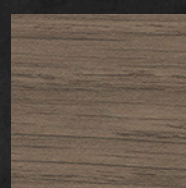

Hazel Oak

DRAWER FRONTS

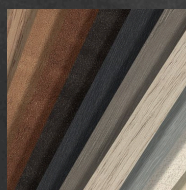

Matching
sides & top

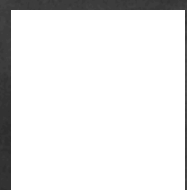

Premium Flat
White

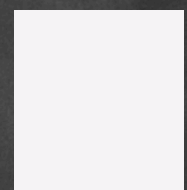

High Gloss
White

ALUMINIUM

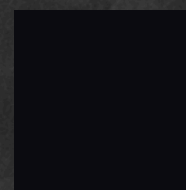

Black

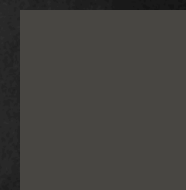

Ash

Note: These are our most popular finishes, although you can choose any finish from the Polytec and Laminex ranges

DRAWER BOXES/CABINET HANDLES

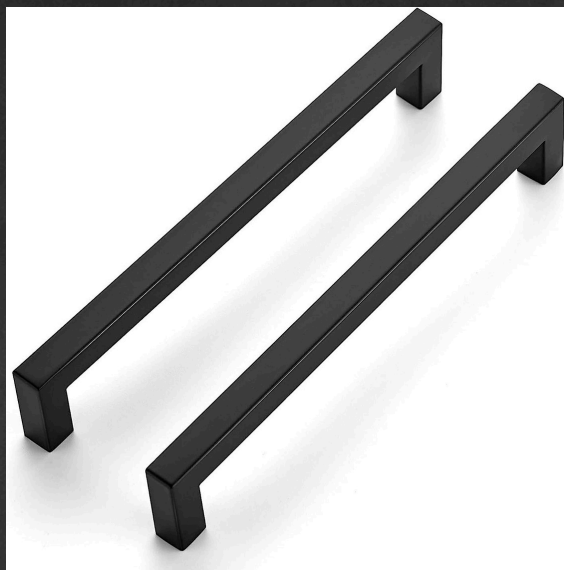

Hafele Jet Black Matt



Hafele Ash Oil Rubbed Bronze

Note: You also choose to supply Your Own Handles.

DRAWER RUNNER OPTIONS

Blum Legrabox Push to Open



Load Bearing: 40KG

Manufacture Location: Austria

Warranty: Lifetime Warranty

Features: Drawer fronts do not require handles.

Hafele Soft Close Alto Slim



Load Bearing: 35KG

Manufacture Location : Germany

Warranty: Lifetime Warranty

Features: Drawer front requires handles.

PREMIUM BRANDS WE WORK WITH

polytec

Laminex®

Hettich

 **blum**®

E EGGER

wilson
&bradley

DIAS

HÄFELE



ELITE WARDROBES BY THE WARDROBE MAN

4/22 Prestige Parade

Wangara WA 6065

t: (08) 9409 6706

e: sales@wardrobeman.com.au

elitewardrobes.au