

Installation and ventilation requirements

What are the installation space and design considerations?

In most cases, Weber Outdoor Kitchens must be installed against a wall, constructed from a non-combustible material. If you're looking to design your outdoor kitchen as an island, this can be accommodated as a custom design, as it requires additional panels along the back of your kitchen (subject to availability of backing board material).

Weber outdoor kitchens must be installed at least 60 cm clear from any combustible materials (including windows), unless a compliant non-combustible barrier is used.

Consider the availability of services (ie. natural gas, water, electricity), and how easily you will have access to them, when choosing the location for your kitchen and the modules you might choose to include. Weber Technicians really are craftsmen, but they're not electricians, gas fitters or plumbers. If you're wanting power, water or natural gas connections in your outdoor kitchen, you'll need to factor the time and cost of getting the trades in to assist pre-installation of your Weber Outdoor Kitchen. Your in store design consultant will be able to provide you with more details on where these connections should be to best meet your design.

What are the ventilation requirements?

You can install a Weber Outdoor kitchen on a balcony, a verandah, patio, partially enclosed alfresco area or completely open alfresco area – as long as it complies with the Australian and New Zealand Standard for the use of outdoor gas appliances.

Weber does not set the standard – but is required to comply with them. Please be aware that these requirements are stringently adhered to by Weber technicians.

If you're installing the Weber Outdoor Kitchen with a gas appliance into an 'enclosure' of any type (eg. with any walls or overhead cover), the enclosure must comply with one of the following:

- An enclosure with walls on all sides, but at least one permanent opening at ground level and no overhead cover (refer to diagram 1)
- Within a partial enclosure that includes an overhead cover and no more than two walls permanently open and unrestricted, equal to at least 50% of the total wall area (refer to diagram 2)
- Within a partial enclosure that includes an overhead cover and more than two walls, the following shall apply (refer to diagrams 3):
 - » at least 25% of the total wall area is completely and permanently open and unrestricted; and
 - » at least 30% of the remaining wall area is open and unrestricted
- In the case of balconies, at least 20% of the total of the side, back and front wall areas shall be and remain permanently open and unrestricted.
- It is important to note that the use of windows, café blinds or louvres are not considered to be a permanent opening (they are considered a restriction).

1

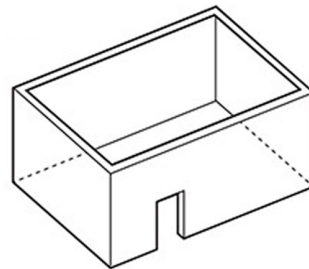

2

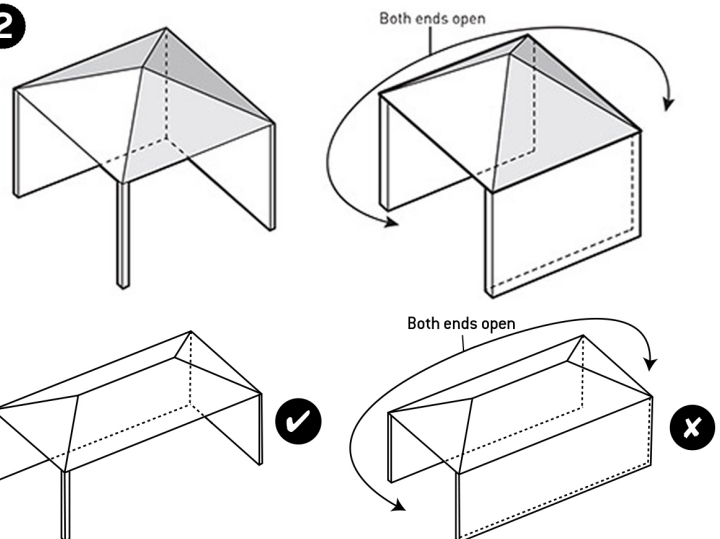

3

