

DESIGN GUIDE

VERSION 4.0 FEBRUARY 2023

STOPDIGGING!
THE GROUND SCREW FOR SOLID FOUNDATIONS



CONTENTS

How this document is organised	2
Purpose	2
Description	2
Part 1 Buildings within the design scope of NZS 3604:2011 or NASH Standard Part 2	3
Scope	3
Skills required	3
Important documents	3
Worked examples for Part 1	3
Design Process	3
Overview	3
Step 1: Confirm building scope	3
Step 2: Confirm ground conditions	3
Step 3: Design timber subfloor and STOPDIGGING! ground screw foundation system	4
Step 4: Specify fixings	4
Step 5: Select ground screw	5
Part 2 For building projects requiring specific engineering design	6
Scope	6
Skills required	6
Important documents	6
Example calculations for Part 2	6
Design Process	6
Overview	6
Step 1: Confirm ground conditions	6
Step 2: Design STOPDIGGING! ground screw foundation system	7
Step 3: Specify fixings	9
Step 4: Select ground screw	9
Appendix 1 – Soil suitability	10
Appendix 2 – Design and Test Loads	11
Appendix 3 – Foundation System Worked Examples	12
Appendix 4 – Example engineering calculations	15

HOW THIS DOCUMENT IS ORGANISED

PURPOSE	<p>This guide provides:</p> <ul style="list-style-type: none">a. the information to design and specify a STOPDIGGING! ground screw foundation system without the need for specific engineering (Part 1) andb. the advice necessary to design and specify a STOPDIGGING! ground screw foundation system where a specific engineering design (SED) is required (Part 2).
DESCRIPTION	<p>STOPDIGGING! ground screws are circular hollow sections with a continuously welded helix manufactured from steel that complies with ISO 630 FE360A–High Tensile Steel for Structural Purposes. They are coated with a hot-dipped galvanised coating that achieves an average of 125 µm zinc cover. The STOPDIGGING! ground screws are classified as category HDG900 (900 g/m²).</p> <p>They are capable of resisting vertical (tensile and compression) and lateral forces. Therefore, they can be specified as a proprietary foundation system, an alternative to traditional foundation piles and strip footings as defined in NZS 3604:2011, or a foundation subject to SED.</p> <p>STOPDIGGING! ground screws are mechanically installed into soil to a depth at which the required resistance is achieved. The screws can be installed without disturbance or damage to the ground. Concrete is not required.</p> <p>STOPDIGGING! ground screws are supplied in various screw diameters with extensions, adapters, and connection brackets. The actual diameter and length of ground screws are established at the time of installation and based on the compressive and lateral loads achieved. The screws are reusable and recyclable.</p>

PART 1 **BUILDINGS WITHIN THE DESIGN SCOPE OF NZS 3604:2011 OR NASH STANDARD PART 2**

SCOPE	<p>Part 1 applies to projects where the STOPDIGGING! ground screw foundation system is to be used</p> <ul style="list-style-type: none">› Subfloor designed to NZS3604:2011 or to NASH Std. Part 2:May 2019 and design floor loads do not exceed 3kPa¹. <p>For projects that fall outside this scope, including where the structure is founded on a concrete slab. refer to Part 2 of this guide.</p>
SKILLS REQUIRED	<p>Part 1 is intended for use by licensed building practitioners (LBP), or deemed LBP, licensed to the applicable class.</p> <p>Where consent is not required, then this part of the guide is also intended for use by a person competent to use the subfloor standards.</p>
IMPORTANT DOCUMENTS	<p>When using Part 1 of this guide, the following documents will also be required:</p> <ul style="list-style-type: none">› CodeMark Certificate of Conformity (where building consent applies)› STOPDIGGING! Installation Guide› the subfloor standards. <p>Refer to www.stopdigging.co.nz for current versions of STOPDIGGING! documents. A copy of NZS 3604:2011 may be downloaded from https://www.standards.govt.nz/shop/nzs-36042011/.</p> <p>A copy of the NASH standard may be downloaded from https://nashnz.org.nz/publications/downloads/.</p>
WORKED EXAMPLES FOR PART 1	<p>Worked examples are provided for the following scenarios:</p> <ul style="list-style-type: none">› Example 1: Level site with cantilevered piles› Example 2: Level site with Anchor and ordinary piles› Example 3: Sloping ground with cantilevered piles. <p>The worked examples are contained in Appendix 3.</p>
DESIGN PROCESS	<p>Overview</p> <p>The design process can be divided into three sections:</p> <ul style="list-style-type: none">› confirming that the project falls within the scope of part 1 of this design guide,› confirming ground conditions,› designing subfloor and STOPDIGGING! ground screw foundation system. <p>Refer to Appendix 3 for worked examples of the design process.</p>
Step 1:	<p>Confirm building scope</p> <p>Confirm that the Subfloor is designed to NZS3604:2011 or to NASH Std: Part 2 May 2019 and design floor loads do not exceed 3kPa.</p>
Step 2:	<p>Confirm ground conditions</p> <p>Note: In all installations, ground conditions are confirmed immediately prior to installation.</p> <p>Check the soil suitability</p> <p>Table 2, Appendix 1 provides a soil suitability matrix. Confirm that the site specific soil type is listed as suitable.</p>

¹ NZS3604 and NASH std are collectively referred to in this document as the "subfloor standard".

Where the soil is not covered in Table 2 site soil testing and a Geotechnical report will be required as part of the design process.

Confirm ground stability

From council files and the applicable GIS determine if liquefaction or other ground stability must be factored in when designing the foundation system.

Where these geotechnical features need to be considered a Geotechnical report will be required for the design stage.

Step 3:

Design timber subfloor and STOPDIGGING! ground screw foundation system

NZS 3604:2011 design methodology is to be followed when designing a timber or lightweight steel subfloor with piles (ground screws).

NZS 3604:2011 provides the dimensions and bracing units for a foundation system for a given load (e.g., NZS 3604:2011, Table 6.1). However, the STOPDIGGING! ground screw foundation system requires specification of ULS design loads assigned to piles, which are then confirmed at installation.

When used in conjunction with a timber subfloor, the ground screws can:

- > act as cantilever 'free head' piles or
- > as an anchor/ordinary pile system.

ULS calculated load

Appendix 2 provides tables that identify individual pile design loads that are to be used for static pile test targets. Test loads designated in the table allow a geotechnical safety factor.

A static pile test should be provided to 100 % of the 'Test Load' in the table.

Diagonal bracing units

Where the head of the ground screw is expected to be ≥ 900 mm above the ground, the on-site lateral load test must establish that the lateral load can be met.

Where the on-site testing demonstrates that lateral loads cannot be met, then there are three solutions:

1. a ground screw with a larger diameter is installed and lateral load confirmed, or
2. install a diagonal steel pipe bracing unit, or
3. a ground screw with steel bracket may be used to support a timber senton post. Timber diagonal bracing can then be installed to the senton posts in accordance with NZS 3604:2011.

Where diagonal bracing is required, engineering design is required (Part 2 of this guide).

Step 4:

Specify fixings

Ground screw to bearer connection

SGL 145 Bracket should be used for fixing bearer to pile. The bracket is fixed through a slotted hole using an M20 threaded bolt in the centre of the screw.

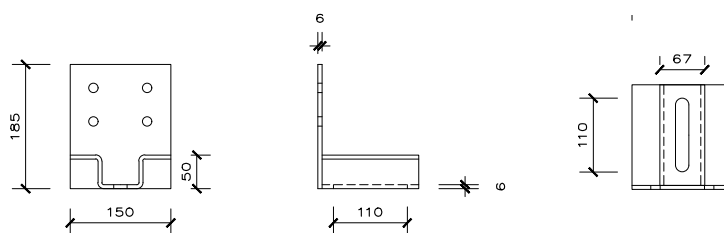

FIGURE 1. BRACKET SGL145

There are two fixing options for the SGL 145 bracket that achieve a 6 kN fixing

- 1 x M12 bolt through bearer c/w 50 x 50 x 6 mm square washer, or
- 2 x M12 coach screws (75 mm long) with 50 x 50 x 6 mm square washer.

The bracket may be positioned in one of three orientations on the head of the screw depending on the position of the bearer relative to the head of the screw.

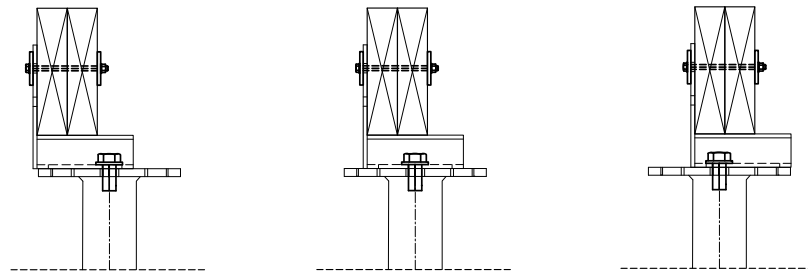

FIGURE 2 POSITION OF GROUND SCREW

Ground screw to pile or post connection

Use the SGE 125 bracket when fixing to timber senton piles.

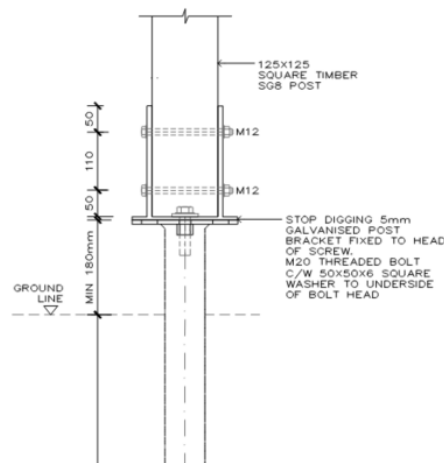

FIGURE 3 BRACKET SGE125 FIXED TO SENTON PILE.

Step 5:

Select ground screw

For decks specify the STOPDIGGING! beam screw – SGU 95.

For all other uses, specify STOPDIGGING! adapter screw – SGC 76Ø or SGC 89Ø.

Adapter screws are used in conjunction with brackets SGL 145, SGE 125, and SGE 95 where required and as established on-site.

PART 2 **FOR BUILDING PROJECTS REQUIRING SPECIFIC ENGINEERING DESIGN**

SCOPE This part applies to projects where the STOPDIGGING! ground screw foundation system is to be used for projects where the design floor loads are > 3kPa, or where the structure is founded on a concrete slab.

SKILLS REQUIRED This part is intended for use by a CPEng engineer. It is expected that the engineer will complete the STOPDIGGING! design declaration in respect of the design work.

IMPORTANT DOCUMENTS When using this part, the following documents will be required when lodging an application for building consent:

- › CodeMark Certificate of Conformity
- › STOPDIGGING! Installation Guide
- › Specific engineering design and calculations
- › CPEng signed STOPDIGGING! Design Declaration.

Refer to www.stopdigging.co.nz for current versions of STOPDIGGING! documents.

EXAMPLE CALCULATIONS FOR PART 2 Example calculations show how to apply engineering calculations in conjunction with the STOPDIGGING! brackets and ground screws to calculate fixing requirements. The calculations are contained in [Appendix 4](#).

DESIGN PROCESS **Overview**
The design process can be divided into three sections:

- › confirming ground conditions
- › specifying design loads for the STOPDIGGING! ground screw foundation system
- › specify fixings.

Refer to [Appendix 4](#) for example engineering calculations for fixing requirements.

Step 1: **Confirm ground conditions**
Note: In all installations, ground conditions are confirmed immediately prior to installation.

Check the soil suitability

[Table 2](#), [Appendix 1](#) provides a soil suitability matrix. Confirm that the site specific soil type is listed as suitable.

Where the soil is not covered in [Table 2](#) site soil testing and a Geotechnical report will be required as part of the design process.

Confirm ground stability

From council files and the applicable GIS determine if liquefaction or other ground stability must be factored in when designing the foundation system.

Where these geotechnical features need to be considered a Geotechnical report will be required for the design stage.

Step 2:

Design STOPDIGGING! ground screw foundation system

Ensure that the engineering design prescribes the position and required design loads for the STOPDIGGING! ground screw foundation system. Ensure that a geotechnical safety factor is included or annotate the design to make it clear that the ULS loads have been calculated without the geotechnical safety factor.

Ground screws can be used to support concrete slabs on grade when piles are needed to transfer loads to a depth below the existing subgrade level.

Suitable uses include:

- Where a geotechnical assessment has identified 'good ground' at a certain depth. The length of screw can be selected to embed the helix within 'good ground' to satisfy the geotechnical requirements. Load testing will be required to confirm the site-specific capacities at the required depth to verify that the design loads can be achieved.
- Where a minimum embedment depth is required to avoid the surface effects of expansive soils. The length of screw can be selected to embed the helix below the recommended depths for different expansivity classes.
- Where building work is proposed close to or over underground services/pipes. The length of screw can be selected to transfer loads below the influence line of the pipe.
- Where shear keys are required, the ground screws can act as free head piles to resist lateral loads. Load testing will be required to confirm the site-specific lateral capacity of the ground screw when installed to cleared ground level.

Ground screws supporting concrete slabs

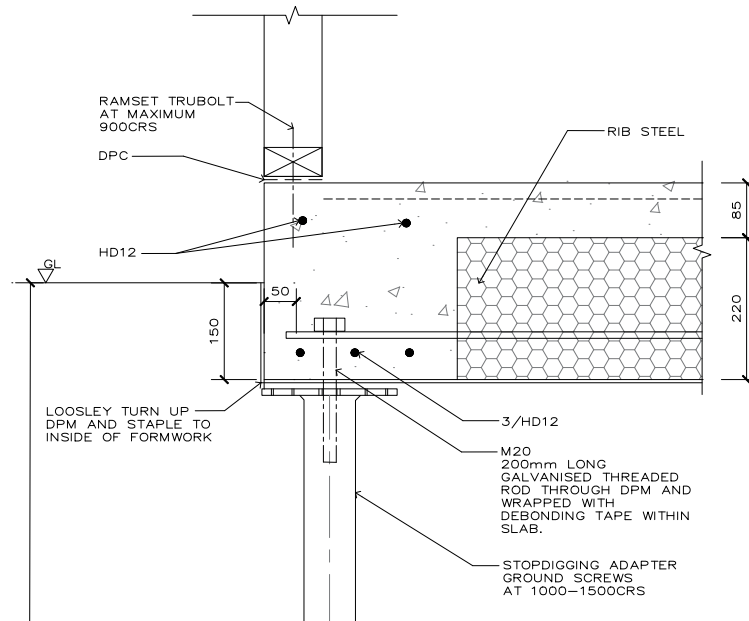

FIGURE 4 GROUND SCREW SUPPORTING CONCRETE SLAB

Diagonal bracing units

Where the head of the ground screw is expected to be ≥ 600 mm above the ground, on-site lateral load test must establish that the lateral load can be met.

Where the on-site testing demonstrates that lateral loads cannot be met, then there are two solutions:

1. a ground screw with a larger diameter is installed and lateral load confirmed, or
2. a diagonal bracing unit is used.

A diagonal bracing unit creates an alternative load path to distribute lateral loads from subfloor level to foundation level.

The diagonal bracing unit must be specified as follows:

- > 48.3 CHS Grade 250 tube.
- > A maximum length of 3.2 m.
- > At an angle between 10° and 45° from horizontal.
- > The bracing unit is to be connected with a scaffolding coupler that has an established capacity of greater than 6 kN.
- > The bracing unit must be fixed at least 100 mm above ground level.

Where diagonal steel pipe bracing is used, lateral testing must be completed at the height of application of load from the diagonal braces. Vertical testing must be completed at the maximum height that the ground screws are installed.

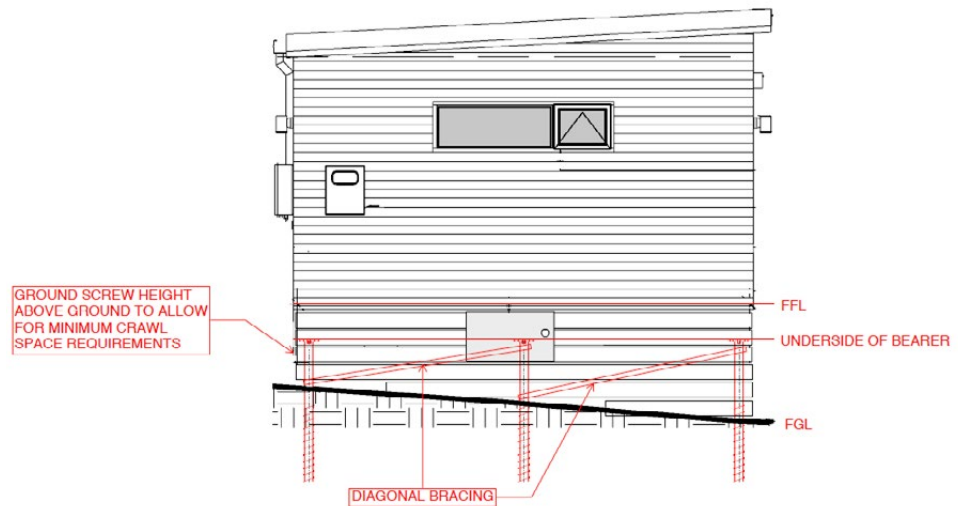

FIGURE 5: DIAGONAL BRACING

Step 3:

Specify fixings

The following steps should be carried out to calculate fixing requirements:

- › Select project values using the following table:

TABLE 1: SECTION CAPACITIES

	New (Complete Section)				50-year Design Life (0.5 mm reduced wall thickness)				100-year Design Life (1 mm reduced wall thickness)			
	600		1200		600		1200		600		1200	
Installed Height Above Ground (mm)	600		1200		600		1200		600		1200	
CHS Section Size	N _s	M _s	N _c	M _n	N _c	M _n	N _c	M _n	N _c	M _n	N _c	M _n
89x5	308.5	6.2	297.7	6.2	279.3	5.6	269.5	5.6	249.8	5.1	241.0	5.1
89x4	249.8	5.1	241.0	5.1	220.0	4.5	212.3	4.5	189.7	4.0	183.0	4.0
76x4	210.5	3.6	200.7	3.6	185.5	3.2	177.0	3.2	160.2	2.8	152.8	2.8
67x3	139.6	2.2	131.5	2.2	117.4	1.9	110.6	1.9	94.6	1.5	89.3	1.5
67x2	94.6	1.5	89.3	1.5	71.5	1.2	67.5	1.2	48.1	0.8	45.4	0.8

› Abbreviations

- N_s = nominal section capacity of compression member (kN)
- M_s = nominal section moment capacity (kNm)
- N_c = nominal member capacity in compression (kN)
- M_n = nominal member moment capacity (kNm)

› Calculate for combined action.

› Calculate for bearer connection using STOPDIGGING! brackets. The following steps are required:

- Specify the connection from the bearer to the bracket.
- Consider the bending capacity of the steel bracket.
- Design the weld strength between the plates.
- Specify steel bolt in slotted hole - bracket to ground screw connection.
- Calculate bearing length of bearer on to bracket.

Refer to [Appendix 4](#) for example engineering calculations for fixing requirements.

Step 4:

Select ground screw.

For decks specify the STOPDIGGING! beam screw – SGU 95.

For all other uses, specify STOPDIGGING! adapter screw – SGC 76Ø or SGC 89Ø.

Where the specifying engineer requires additional durability, SGC 89Ø is available with a 5 mm thickness.

Adapter screws are used in conjunction with brackets SGL 145, SGE 125, and SGE 95 where required and as established on-site.

APPENDIX 1 – SOIL SUITABILITY

TABLE 2: SUITABILITY OF GROUND SCREWS BASED ON SOIL TYPE

MAJOR SOIL TYPE	SUITABILITY ²	RATIONALE
Silt	Yes	Silt can generally be predrilled with a suitable soil auger, allowing for installation of the ground screws.
Sand	Yes	Ground screws can generally displace sands during installation.
Fine gravel	Yes	Fine gravels are expected to behave in a similar way to sands.
Medium gravel	Requires on-site confirmation	Medium gravels may become disturbed during installation, diminishing the bond strength between the ground screw and the soil. As such the suitability of the soils will need to be confirmed with on-site testing.
Coarse gravel	Requires on-site confirmation	Coarse gravels may become disturbed during installation, diminishing the bond strength between the ground screw and the soil. As such the suitability of the soils will need to be confirmed with on-site testing.
Cobbles	No	Cobbles are expected to become disturbed during installation or prevent installation altogether due to penetration resistance. Disturbed cobbles would have a greatly diminished bond strength to the installed ground screw.
Boulders	No	It is unlikely that the predrilling process or the ground screw installation will be able to penetrate through soil medium comprising boulders as the main constituent.
Clay	Yes	Clays can generally be augured, allowing the predrilling process to be completed successfully and in most cases shall allow for the successful installation of the ground screws.
Peat	No	Peat is an organically dominated material that is unsuitable for most shallow foundation types.
Topsoil	No	Topsoil is an organically dominated material that is unsuitable for most shallow foundation types.
Rock	No	Predrilling is generally unsuccessful into bedrock and ground screws are unable to displace rock during installation.
Non-engineered fill	No	Non-engineered fills are inconsistent material with unpredictable characteristics. Uncontrolled fill lacks the horizontal stratification that is common in naturally deposited materials. As such, localised soil and load testing cannot be used to infer the performance or the load carrying characteristics of the soil across an entire site.

² Assuming soil is sufficiently dense.

APPENDIX 2 – DESIGN AND TEST LOADS

TABLE 3: 1.5 kPa AND 2 kPa FLOOR LOADS

SPAN* OF		DESIGN & TEST LOADS FOR GROUND SCREWS							
Bearer (m)	Joists (m)	Floor and non-loadbearing walls only		1 storey		2 storey		3 storey	
		Design Load	Test Load	Design Load	Test Load	Design Load	Test Load	Design Load	Test Load
1.30	2.0	6kN	10kN	11kN	20kN	16kN	25kN	18kN	30kN
	3.5	8kN	15kN	18kN	30kN	27kN	40kN	34kN	50kN [†]
	5.0	11kN	20kN	27kN	40kN	40kN	60kN [†]	45kN	70kN [†]
	6.0	14kN	25kN	30kN	45kN [†]	45kN	70kN [†]	55kN	85kN [†]
1.65	2.0	6kN	10kN	14kN	25kN	21kN	35kN	24kN	40kN
	3.5	9kN	15kN	27kN	40kN	33kN	50kN [†]	40kN	60kN [†]
	5.0	14kN	25kN	30kN	45kN [†]	50kN	75kN [†]	55kN	85kN [†]
2.00	2.0	6kN	10kN	16kN	25kN	27kN	40kN	30kN	45kN [†]
	3.5	11kN	20kN	27kN	40kN	41kN	60kN [†]	55kN	85kN [†]

TABLE 4: 3 kPa FLOOR LOADS

MAXIMUM SPANS* OF		DESIGN & TEST LOADS FOR GROUND SCREWS					
Bearers (m)	Joists (m)	Floor only		Floor and walls of:			
		Design Load	Test Load	1 storey		2 storeys	
		Design Load	Test Load	Design Load	Test Load	Design Load	Test Load
1.30	2.0	4kN	10kN	7kN	15kN	11kN	20kN
	3.5	7kN	15kN	24kN	40kN	38kN	60kN [†]
	5.0	8kN	15kN	30kN	45kN [†]	50kN	75kN [†]
	6.0	9kN	15kN	38kN	60kN [†]	59kN	90kN [†]
1.65	2.0	7kN	15kN	9kN	15kN	27kN	40kN
	3.5	8kN	15kN	27kN	40kN	50kN	75kN [†]
	5.0	11kN	20kN	38kN	60kN [†]	63kN	95kN [†]
2.00	2.0	6kN	10kN	11kN	20kN	34kN	50kN [†]
	3.5	11kN	20kN	34kN	50kN [†]	59kN	90kN [†]

*Span is the average of the bearer or joist spans on either side of the pile under consideration.

[†]Special consideration is required for these loads, please check with STOPDIGGING! to confirm the availability of the larger capacity testing and installation equipment..

Note: the above tables relied on the following assumptions

ULS bearing capacity = 150 kPa

ULS vertical capacity of pad = 150 kPa x 0.275m x 0.275 m = 11 kN

APPENDIX 3 – FOUNDATION SYSTEM WORKED EXAMPLES

The following worked examples are provided for the following scenarios that relate to **Part 1**:

- › Example 1: Level site with cantilevered piles
- › Example 2: Level site with Anchor and ordinary piles
- › Example 3: Sloping ground with cantilevered piles.

FOUNDATION SYSTEM WORKED EXAMPLES

Example 1: Level site with cantilevered piles

All ground screw foundations are to act as cantilevered piles with the total subfloor bracing demand being shared by all screws.

All ground screws must have connections to the bearer that are suitable to transfer the required lateral load per screw. The STOPDIGGING! SGL 145 bracket should be used.

On-site testing is completed at the maximum height that the ground screws are installed to provide accurate ultimate load capacities.

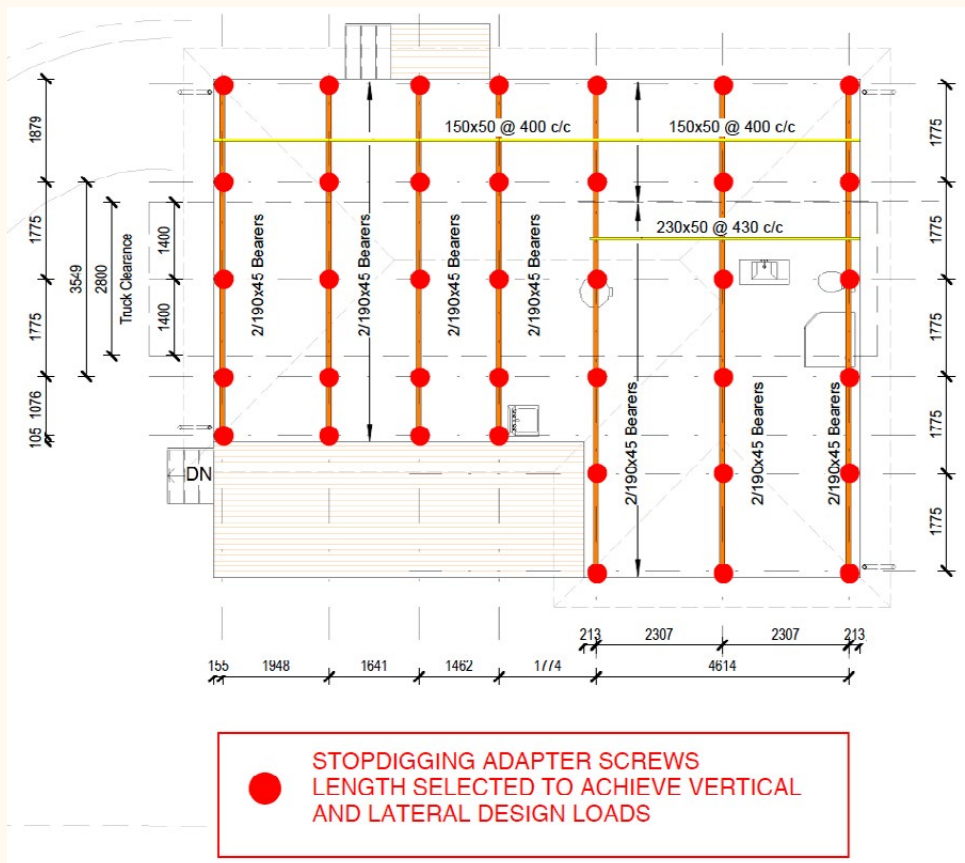

Example 2: Level site with anchor and ordinary pile

Anchor piles (anchor screws) are nominated on subfloor bracing lines to resist the subfloor bracing demand. Anchor screws must have connections to the bearer that are suitable to transfer the required lateral load per anchor pile. The STOPDIGGING! SGL 145 bracket should be used.

Ordinary piles are required to support vertical loads only. For simplicity the STOPDIGGING! SGL 145 bracket should be used.

On-site testing is completed at the maximum height that the ground screws are installed to provide accurate ultimate load capacities.

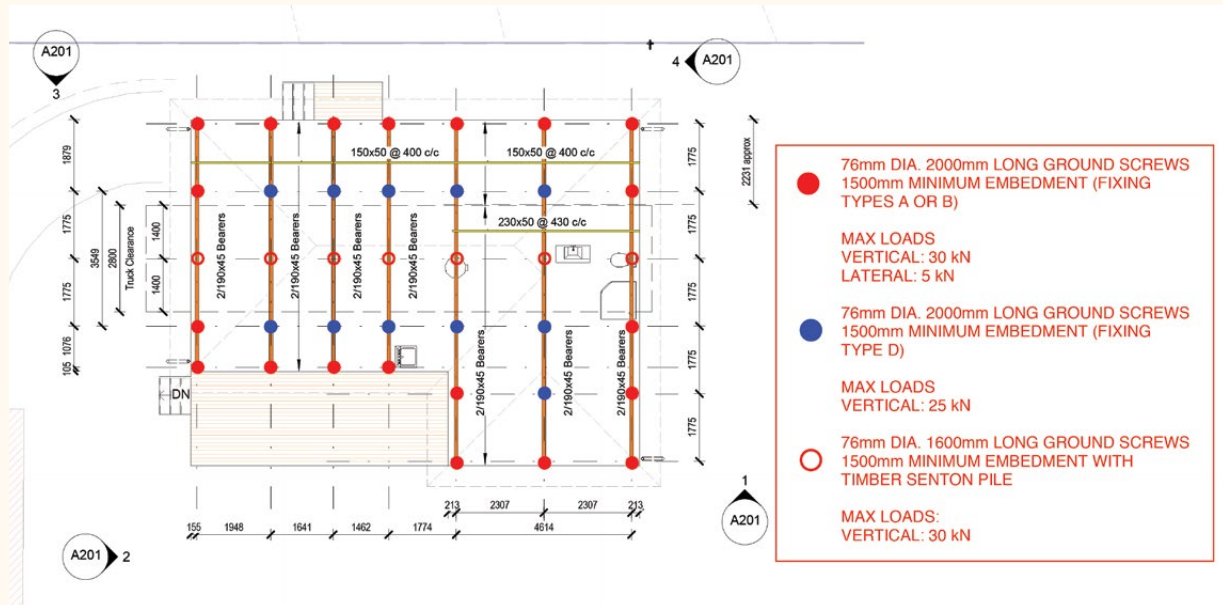

Example 3: Sloping ground with cantilevered piles

All ground screw foundations to act as cantilevered piles so that the total subfloor bracing demand can be shared by all piles.

All ground screws must have connections to the bearer that are suitable to transfer the required lateral load per screw. The STOPDIGGING! SGL 145 bracket should be used.

On-site testing is completed at the maximum height that the ground screws are installed to provide accurate ultimate load capacities.

Larger diameter and longer screws can be used to provide additional stiffness and embedment depth where needed to provide lateral capacity to screws with greater clearances to the underside of the bearer.

Note additional testing must be completed by STOPDIGGING! for each length/size of screw.

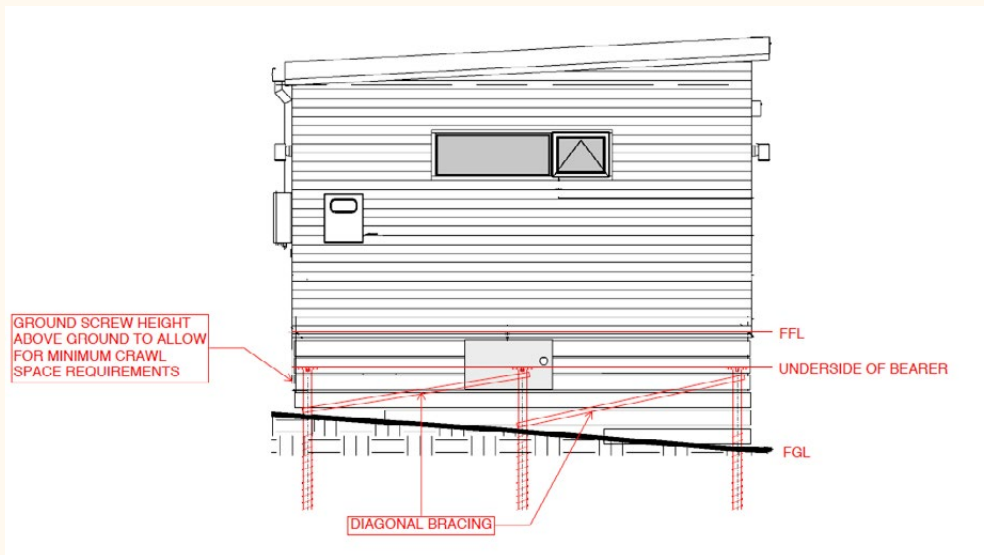

APPENDIX 4 – EXAMPLE ENGINEERING CALCULATIONS

The following examples show how to apply engineering calculations in conjunction with the STOPDIGGING! brackets and ground screws.

All abbreviations have the meaning provided in steel and timber engineering standards and are given the normally accepted meaning.

EXAMPLE CALCULATIONS FOR FIXING REQUIREMENTS

Calculate for combined action

Assume project values as follows using Table 1 Section capacities (refer to [Part 2](#)):

Section:	76 x 4 Ground Screw
Height above Ground:	600 mm
Assumed Design Life:	100 years
Vertical Load (ULS)	$N = 20 \text{ kN}$
Lateral Load (ULS)	$V = 3 \text{ kN}$

Calculations are as follows

$$\begin{aligned}
 M^* &= 0.6 \text{ m} \times 3 \text{ kN} &= 1.8 \text{ kNm} \\
 \Phi M_n &= 0.9 \times 2.8 \text{ kNm} &= 2.5 \text{ kNm} \\
 \Phi N_c &= 0.9 \times 160.2 \text{ kN} &= 144.2 \text{ kN} \\
 \Phi M_r &= \Phi M_b \times (1 - (N^* / \Phi N)) \\
 &= 2.5 \text{ kNm} \times (1 - (20 / 137.5)) &= 2.1 \text{ kNm} > M^*
 \end{aligned}$$

Calculate for bearer connection

Use STOPDIGGING! SGL 145 designed to transfer lateral load of 3 kN from the bearer to the ground screw head.

SGL 145 Bracket should be used for fixing bearer to pile. The bracket is fixed through a slotted hole using an M20 threaded bolt in the centre of the screw.

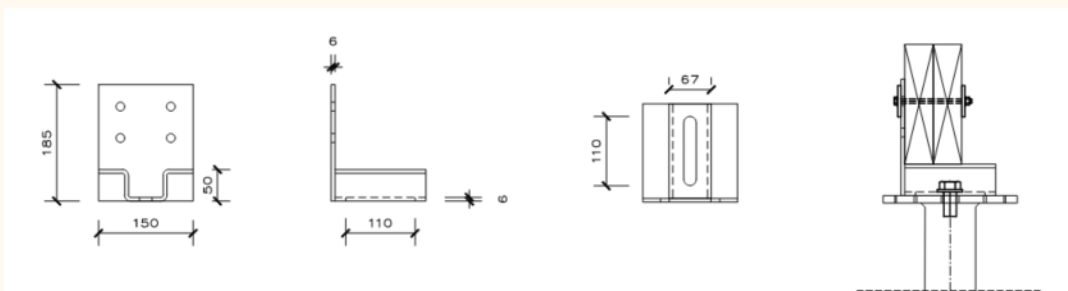

1. Specify connection from bracket to bearer

Option A: 1 x M12 bolt

Bolt acting in tension (loaded at 90° to bearer)

$$N^*_{t} = 3 \text{ kN}$$

Tensile capacity of M12 bolt confirmed by inspection
 ($\Phi N_t = 27.0 \text{ kN}$)
 Connection is governed by the bearing strength of the washer.
 Propose 50 mm x 50 mm x 6 mm square washers.

$$A_p = (50 \text{ mm})^2 - \pi \times (14 \text{ mm})^2 / 4$$

$$= 2356 \text{ mm}^2$$

$$\Phi N_{nb} = \Phi \times k_1 \times k_3 \times f_p \times A_p$$

$$= 0.7 \times 1.0 \times 1.0 \times 8.9 \text{ MPa} \times 2356 \text{ mm}^2 / 1000$$

$$= 14.7 \text{ kN}$$

$$= > 0.3 \text{ kN}$$

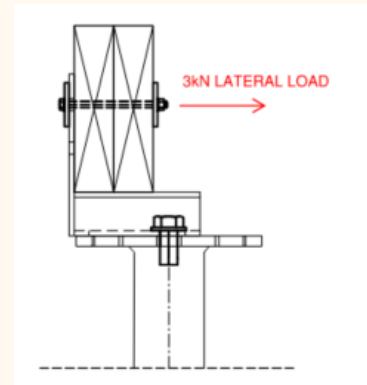

Bolt acting in shear (loaded at 0° to bearer)

Loading parallel to grain

$$B_e = 90 \text{ mm}$$

$$Q_{skl} = 10.4 \text{ kN} \times 1.25$$

$$= 13.0 \text{ kN}$$

(Alternative steel & timber members)

$$\Phi Q_n = \Phi \times n \times k_1 \times k_{12} \times k_{13} \times Q_{sk}$$

$$= 0.7 \times 1.0 \times 1.0 \times 1.0 \times 1.0 \times 13.0$$

$$= 9.1 \text{ kN}$$

$$> 3 \text{ kN}$$

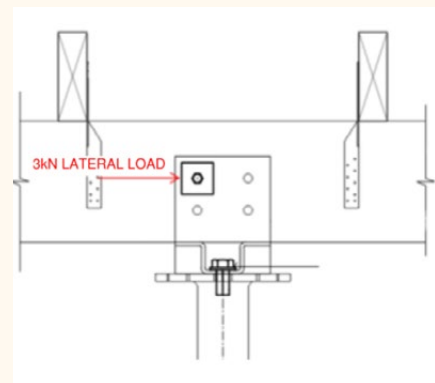

Option B 2 x M12 75 mm coach screws

Coach screws acting in tension (loaded at 90° to bearer)

$$N^*_{t} = 3 \text{ kN}$$

Tensile capacity of M12 coach screw confirmed by inspection. Connection is governed by the withdrawal strength of the coach screw.

Propose 2 mm x 75 mm M12 coach screws.

$$\text{Coach screw embedment} = 75 \text{ mm} - (6 \text{ mm} + 5 \text{ mm}) = 64 \text{ mm}$$

$$\Phi Q_n = \Phi \times n \times k_1 \times p \times Q_k$$

$$= 0.7 \times 2.0 \times 1.0 \times 64 \text{ mm} \times 118 \text{ N/mm} / 1000 = 10.6 \text{ kN}$$

$$> 3 \text{ kN}$$

Coach screws acting in shear (loaded at 0° to bearer)

Loading parallel to grain

$$B_e = 90 \text{ mm}$$

$$Q_{skl} = 10.4 \text{ kN} \times 1.25 = 13.0 \text{ kN}$$

(Alternative steel & timber members)

$$\Phi Q_n = \Phi \times n \times k_1 \times k_{12} \times k_{13} \times k \times Q_{sk}$$

$$= 0.7 \times 2.0 \times 1.0 \times 1.0 \times 1.0 \times 0.5 \times 13.0$$

$$= 9.1 \text{ kN}$$

$$> 3 \text{ kN}$$

2. Consider bending capacity of steel bracket

Steel yield

Stress $f_y = 250$ MPa

Plate thickness, $t = 6$ mm

Plate bending strength at section A:

$$\begin{aligned} \Phi M_n &= \Phi \times f_y \times Z \\ Z &= b \times d^2 / 4 \\ &= 150 \times 62^2 / 4 = 1350 \text{ mm}^3 \\ \Phi M_n &= \Phi \times f_y \times Z \\ &= 0.9 \times 250 \text{ MPa} \times 1350 \text{ mm}^3 \times 10^{-6} \\ &= 0.30 \text{ kNm} \end{aligned}$$

Propose M12 bolt in top hole (worst case³)

$$\begin{aligned} M^* &= 3 \text{ kN} \times 0.1 \text{ m} \\ &= 0.30 \text{ kN therefore OK.} \end{aligned}$$

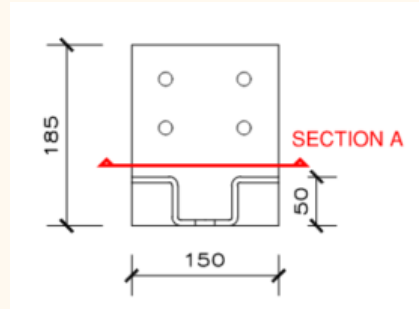
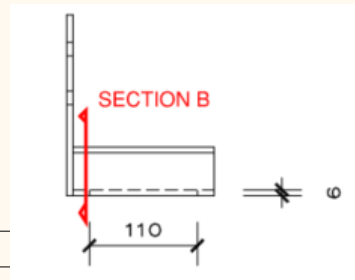

Plate bending strength at section B:

Calculate section properties of irregular section:

PART	A (mm ²)	I (mm ⁴)	y (mm)	I _y	d (mm)	Ad ²
1	228	684	3	2052	22	110352
2	192	16384	25	409600	0	0
3	90	270	47	12690	22	43560
TOTAL:		34676		848684		



$$\begin{aligned} y' &= 848684 / 34676 \\ &= 25 \text{ mm} \\ I_{\text{section}} &= I + Ad^2 \\ &= 342500 \text{ mm}^4 \\ Z_{\text{section}} &= I / y' \\ &= 13700 \text{ mm}^3 \end{aligned}$$

Check slenderness of flanges

$$\begin{aligned} b &= 38 \text{ mm} \\ t &= 6 \text{ mm} \\ \lambda_e &= 6.3 \\ \lambda_{ep} &= 10 \\ &= \lambda_{sp} \\ \lambda_{ey} &= 16 \\ &= \lambda_{sy} \\ \lambda_s &< \lambda_{sy} \text{ therefore, section is compact} \\ Z_e &= 1.5 \times Z \\ &= 20550 \text{ mm}^3 \\ M_s &= 0.9 \times 250 \text{ MPa} \times 20550 \text{ mm}^3 \times 10^{-6} \\ &= 4.6 \text{ kNm} \end{aligned}$$

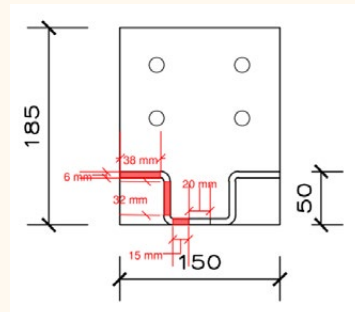

³ M12 bolt to bottom hole would reduce lever arm

3. Design weld strength between plates

Propose 3 mm fillet weld SP 41 as a minimum, both sides of plates.

$$\begin{aligned}\text{Minimum weld length available} &= 30 \text{ mm} \\ \text{Minimum weld strength} &= 2 \times 0.417 \text{ kN/mm} \times 30 \text{ mm} \\ &= 25.0 \text{ kN} \\ N_t^* = 0.3 \text{ kNm}/0.05 \text{ m} &= 6.0 \text{ kN} \\ &< 25.0 \text{ kN therefore OK.}\end{aligned}$$

4. Specify steel bolt in slotted hole - bracket to ground screw connection

As per NZS 3404 section 9.3.3.1

Where slip in the SLS case is required to be limited, a bolt subjected only to a design shear force in the plane of the interfaces shall satisfy:

$$\begin{aligned}V_{sf}^* &\leq \Phi V_{sf} \\ \Phi V_{sf} &= \Phi \times \mu_s \times n_{ei} \times N_{ti} \times k_h \\ \mu_s &= 0.18 \text{ for galvanised surfaces} \\ N_{ti} &= 145 \text{ kN for M20 (g8.8) bolts}\end{aligned}$$

Propose 50 mm x 50 mm x 6 mm square washer

$$\begin{aligned}\text{AREA, } A &= (502 - 50 \times 22) \text{ mm}^2 \\ &= 1400 \text{ mm}^2 \\ \Phi V_{sf} &= 0.7 \times 0.18 \times 2 \times 1400 \text{ mm}^2 \times 145 \text{ kN} \times 0.7 \times 10^{-3} \\ &= 35.8 \text{ kN}\end{aligned}$$

Note: this is an SLS load case; therefore, the shear demand on the bolt will be less than 3 kN.

5. Bearing length of bearer on to bracket

$$\begin{aligned}\text{Minimum bearing length} &= 38 \text{ mm} \\ \text{Distance from end of bearer} &= 25 \text{ mm}\end{aligned}$$

Minimum 90 mm wide bearer

$$\begin{aligned}\text{Bearing area, } A &= 90 \text{ mm} \times 38 \text{ mm} \\ &= 3420 \text{ mm}^2\end{aligned}$$

For SG8 timber bearer:

$$\begin{aligned}\Phi N_b &= \Phi \times k_1 \times k_3 \times f_p \times A \\ &= 2 \times 0.8 \times 0.6 \times 1.0 \times 5.0 \text{ MPa} \times 3420 \text{ mm}^2 \times 10^{-3} \\ &= 16.4 \text{ kN}\end{aligned}$$

Calculate section capacities

Where Table 1 is not relied upon the following is an example calculation for section capacity using NZS3404 clause 6.2.

Example Calculation for section capacity – NZS 3404 clause 6.2

Section: 76 x 4

$$\begin{aligned} A_n &= A_g \\ &= (762 - 682) \times /4 \\ &= 905 \text{ mm}^2 \end{aligned}$$

$k_f = 1.0$

$f_y = 235 \text{ MPa}$

$$\begin{aligned} N_s &= k_f \times A_n \times f_y \\ &= 212.6 \text{ kN} \end{aligned}$$

This document is uncontrolled in printed form.
See www.stopdigging.co.nz for current version.