



## Storage and Hardware

**3monkeez**<sup>®</sup>  
innovate. create. deliver.



2022

**3monkeez**

[www.3monkeez.com.au](http://www.3monkeez.com.au)  
[sales@3monkeez.com.au](mailto:sales@3monkeez.com.au)

# Storage & Hardware

## Contents

Adjustable Glass Rack Kit	3	Ice Well Lid	17
Adjustable Glass Rack Accessories	4	Ice Well Removable Basket	18
Adjustable Dishwasher Rack Kit	5	Stainless Steel Adjustable Feet	19
Adjustable Dishwasher Rack Accessories	6	Nylon Leg Insert	20
Stainless Steel Drawer	7	Nylon Adjustable Feet	21
Stainless Steel Gastronorm Drawer	8	Adjustable Feet	22
Stainless Steel Compact Drawer	9	Plastic Tube Closures	23
Freestanding Drawer Unit 2 Drawer	10	Drawer Handles & Pulls	24
Freestanding Drawer Unit 3 Drawer	11	Stainless Steel Adjustable Leg and Mounting Plate	25
Freestanding Compact Drawer Unit	12	Stainless Steel Hinges	26
Weld In Ice Well	13-14	Utility Lock	27
Drop In Ice Well with Raised Flange	15-16		



# Storage & Hardware



## Adjustable Glass Rack Kit



**BRK-C** (Complete bay)  
**BRK-1** (Add on bay)

- 4 pairs of adjustable stainless steel tray slides to accommodate 4 tiers or 3 tiers and a drip tray (optional)
- Notched channel welded to frame
- Stainless steel fixings with flat bar supports
- Flat packed complete with leg inserts, disc feet and rivets
- Constructed from 25mm 304 grade stainless steel square tubes
- Can be used as a bench support
- 304 grade stainless steel

Top

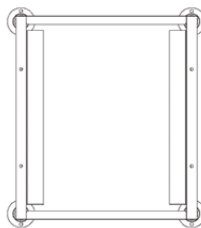

Front

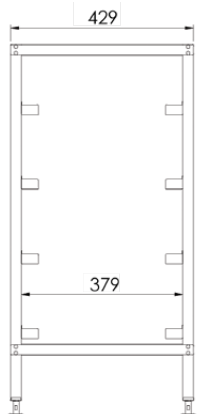

Side

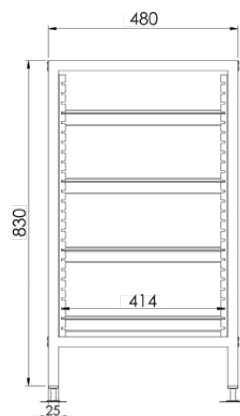
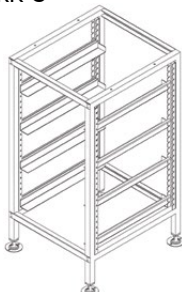
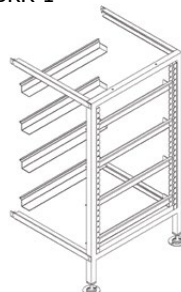

PHOTO SHOWS BRK-C WITH BRK-1

BRK-C



BRK-1



# Storage & Hardware



## Adjustable Glass Rack Accessories



### BRK-DT

(S/S drip tray)

### BRK-NC1

(25mm S/S notched channel)

### AB-BRK-TS

(Pair S/S tray slides - 413mm)

### BRK-TS1

(S/S tray slide - 1000mm)

- 304 grade stainless steel

Drip Tray



BRK-DT

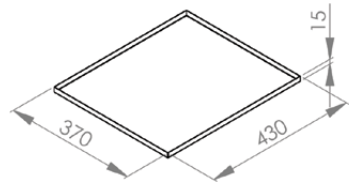

BRK-NC1

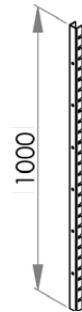

AB-BRK-TS

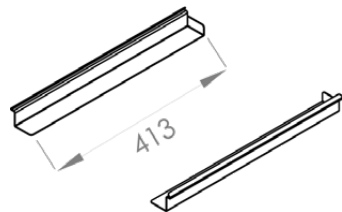

BRK-TS1

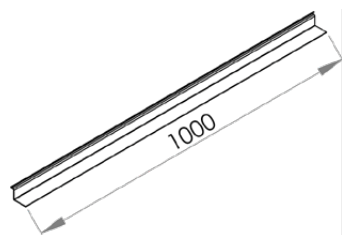

Notched channel

# Storage & Hardware



## Adjustable Dishwasher Rack Kit



**BRK-DW-C** (Complete bay)

**BRK-DW-1** (Add on bay)

- 4 pairs of adjustable stainless steel tray slides to accommodate 4 tiers or 3 tiers and a drip tray (optional)
- Notched channel welded to frame
- Stainless steel fixings with flat bar supports
- Flat packed complete with leg inserts, disc feet and rivets
- Constructed from 25mm 304 grade stainless steel square tubes
- Can be used as a bench support
- 304 grade stainless steel

Top

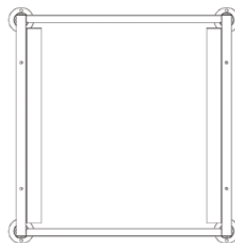

Front

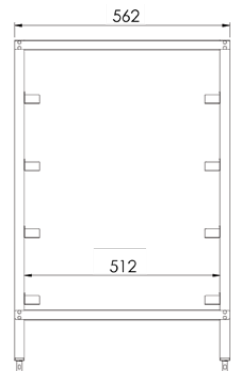

Side

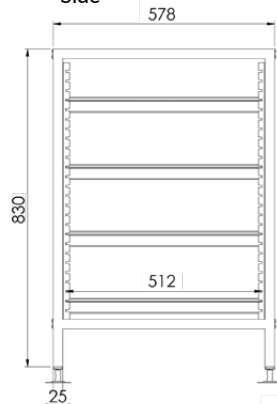
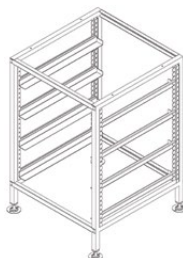

PHOTO SHOWS BRK-DW-C WITH BRK-DW-1

BRK-DW-C



BRK-DW-1



# Storage & Hardware



## Adjustable Dishwasher Rack Accessories



### BRK-DW-DT

*(S/S drip tray)*

### AB-BRK-TS-DW

*(Pair S/S tray slide - 510mm)*

### BRK-TS-DW-L

*(Left S/S tray slide - 510mm)*

### BRK-TS-DW-R

*(Right S/S tray slide - 510mm)*

- 304 grade stainless steel

BRK-DW-DT

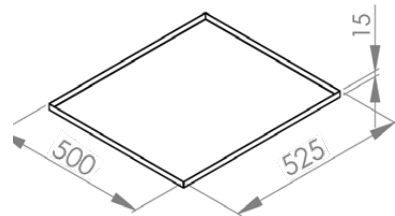

Drip Tray



AB-BRK-TS-DW / BRK-TS-DW-L / BRK-TS-DW-R

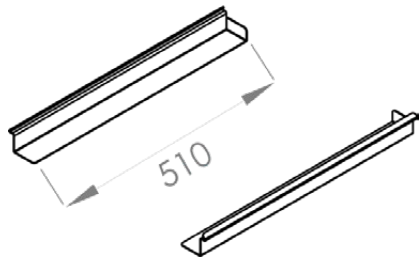

Tray slide



# Storage & Hardware



## Stainless Steel Drawer



### SS DRAWER

### SS DRAWER-L

- Constructed from 1.2mm 304 grade stainless steel
- Heavy duty drawer slides
- Drawers are available with or without a lock
- Pre-drilled fixing holes for under bench mounting
- Optional keyed alike lock

Top

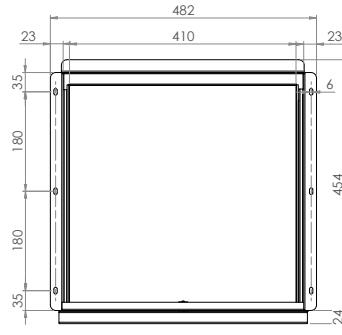

Front

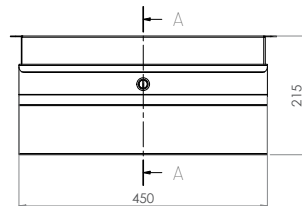

Cross Section

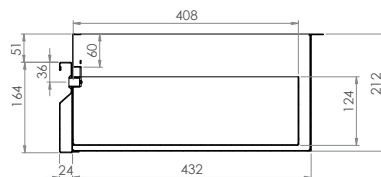

# Storage & Hardware



## Stainless Steel Gastronorm Drawer



### SS DRAWER-1G (suits removable pans)

- Constructed from 1.2mm 304 grade stainless steel
- Heavy duty drawer slide that extends past open to allow pans to be removed with ease
- Pre-drilled fixing holes for under bench mounting
- Under bench mounted
- Lockable
- Specifically designed to allow easy access to pans



Top

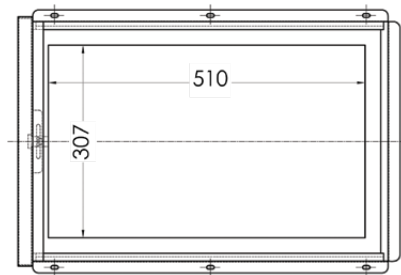

Front

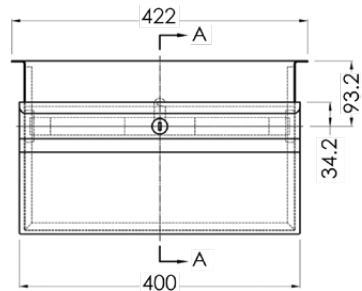

Cross Section

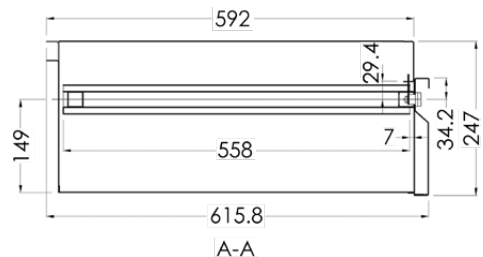



# Storage & Hardware



## Stainless Steel Compact Drawer



### SS CDRAWER-L

- Constructed from 1.2mm 304 grade stainless steel
- Heavy duty drawer slides
- Pre-drilled fixing holes for under bench mounting
- Optional keyed alike lock

Top

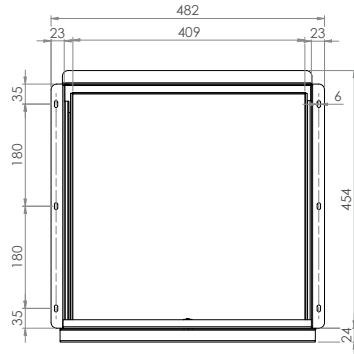

Front

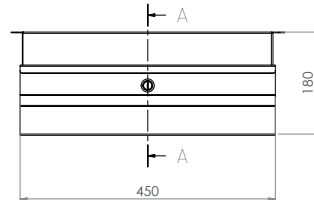

Cross Section

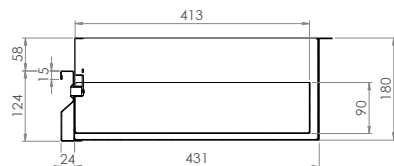

# Storage & Hardware



## Freestanding Drawer Unit



### AB-2DRAW

(2 drawer unit)

### AB-2DRAW-L

(2 drawer lockable unit)

### AB-2DRAW-1G

(2 drawer gastronorm unit)

- Constructed from 304 grade stainless steel
- Heavy duty drawer slides
- Adjustable disc feet
- Standard drawer units are available with or without locks
- Gastronorm units are only available with locks



AB-2DRAW-L

Top

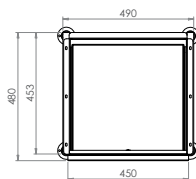

AB-2DRAW-1G

Top

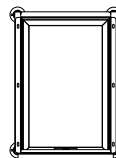

Front

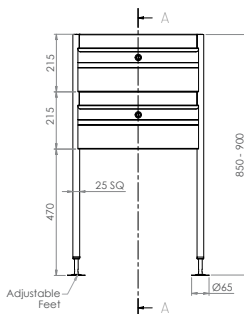

Front

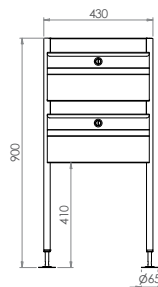

Side

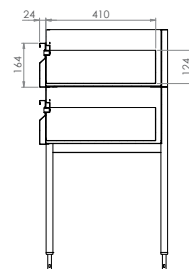

Side

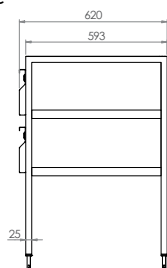

# Storage & Hardware



## Freestanding Drawer Unit



### AB-3DRAW

(3 drawer unit)

### AB-3DRAW-L

(3 drawer lockable unit)

### AB-3DRAW-1G

(3 drawer gastronorm unit)

- Constructed from 304 grade stainless steel
- Heavy duty drawer slides
- Adjustable disc feet
- Standard drawer units are available with or without locks
- Gastronorm units are only available with locks



AB-3DRAW-L

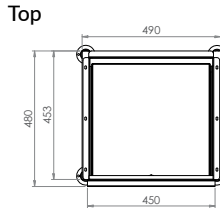

AB-3DRAW-1G

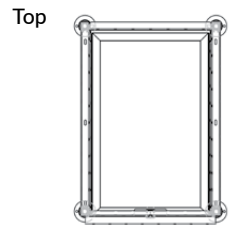

Front

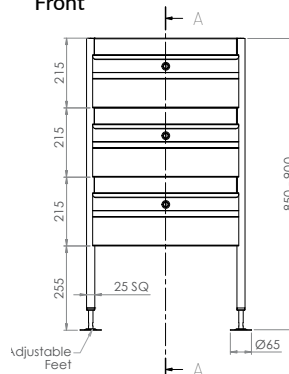

Front

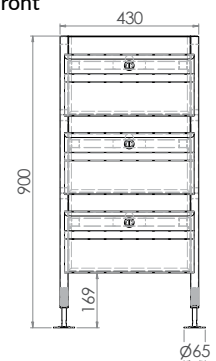

Side

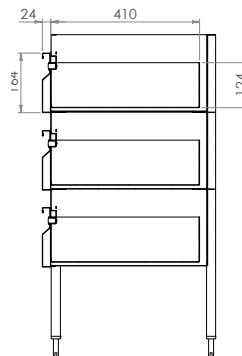

Side

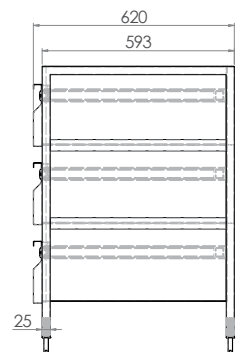

# Storage & Hardware



## Freestanding Compact Drawer Unit



### AB-4DRAW-L (4 drawer lockable unit)

- Constructed from 304 grade stainless steel
- Heavy duty drawer slides
- Adjustable disc feet



Top

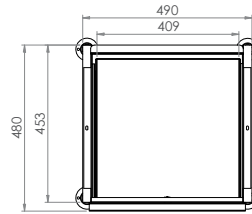

Front

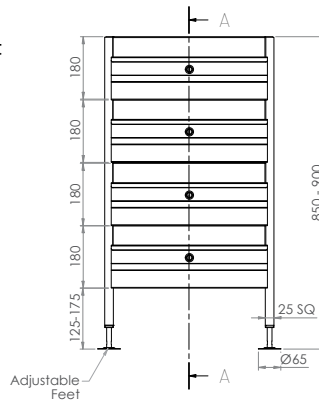

Side

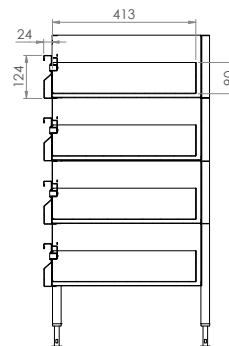

# Storage & Hardware



## Weld In Insulated Ice Well



### ICE-303020

(300mm x 300mm x 200mm)

- Internal skin - constructed from 1.2mm 304 grade stainless steel
- External skin - constructed from 1.2mm 304 grade stainless steel complete with a flange for fixing
- Radius corners and cross breaks to a 25mm centre waste
- Raw edge ready for welding
- 25mm urethane injected insulation
- Ice lid and basket available (optional)
- Custom sizes available, custom made products incur a lead time

Top

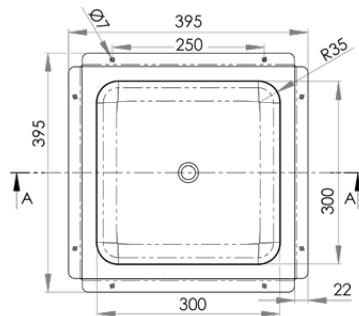

Side

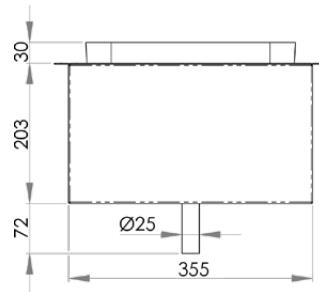

Cross Section

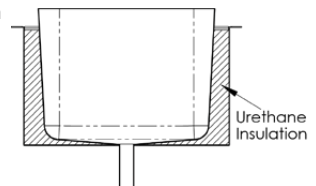

ICEL-303020  
ICEB-303020

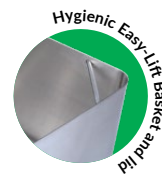

# Storage & Hardware



## Weld In Insulated Ice Well



### ICE-403530

(400mm x 350mm x 300mm)

- Internal skin - constructed from 1.2mm 304 grade stainless steel
- External skin - constructed from 1.2mm 304 grade stainless steel complete with a flange for fixing
- Radius corners and cross breaks to a 25mm centre waste
- Raw edge ready for welding
- 25mm urethane injected insulation
- Ice lid and basket available (optional)
- Custom sizes available, custom made products incur a lead time



Top

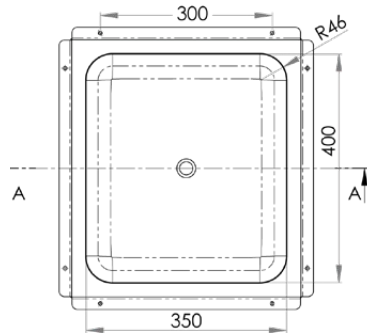

Side

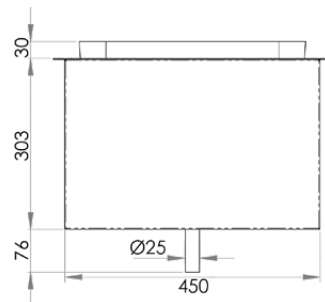

Cross Section

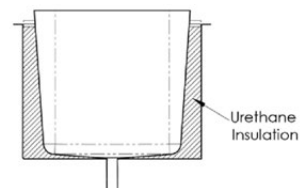

ICEL-403530  
ICEB-403530

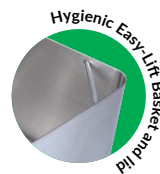

# Storage & Hardware



## Drop In Ice Well with Raised Flange



### ICEDI-303020

(300mm x 300mm x 200mm)

- Internal skin - constructed from 1.2mm 304 grade stainless steel
- External skin - constructed from 1.2mm 304 grade stainless steel complete with a raised flange to prevent cross contamination
- Radius corners and cross breaks to a 25mm centre waste
- 25mm urethane injected insulation
- Ice lid and basket available (optional)
- Custom sizes available, custom made products incur a lead time

Top

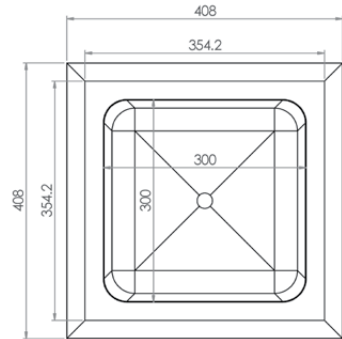

Side

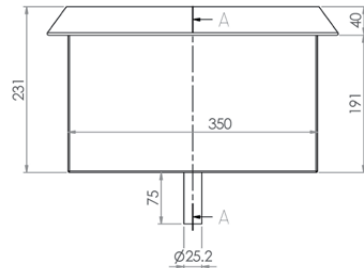

Cross Section

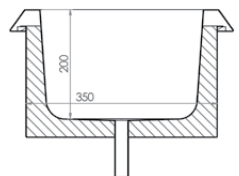

ICEL-303020  
ICEB-303020

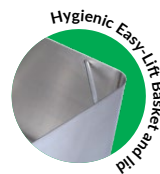

# Storage & Hardware



## Drop In Ice Well with Raised Flange



### ICEDI-403530

(400mm x 350mm x 300mm)

- Internal skin - constructed from 1.2mm 304 grade stainless steel
- External skin - constructed from 1.2mm 304 grade stainless steel complete with a raised flange to prevent cross contamination
- Radius corners and cross breaks to a 25mm centre waste
- 25mm urethane injected insulation
- Ice lid and basket available (optional)
- Custom sizes available, custom made products incur a lead time

Top

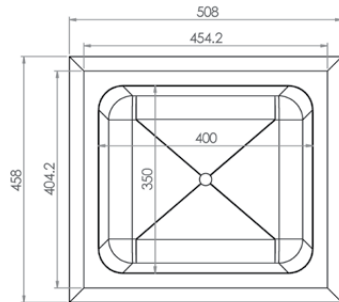

Side

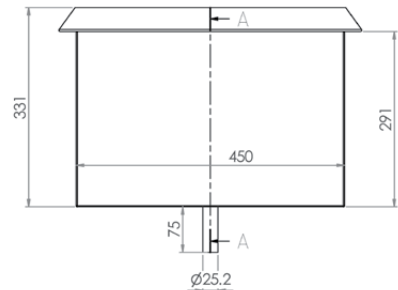

Cross Section

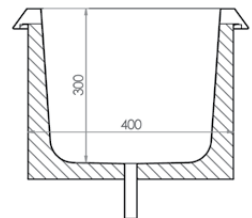

ICEL-403530  
ICEB-403530

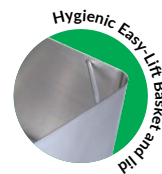



# Storage & Hardware



## Ice Well Lid



### ICEL-303020

- Constructed from 1.2mm 304 grade stainless steel
- Suitable for pairing with ICE-303020 and ICEDI-303020

### ICEL-403530

- Constructed from 1.2mm 304 grade stainless steel
- Suitable for pairing with ICE-403530 and ICEDI-403530

Top

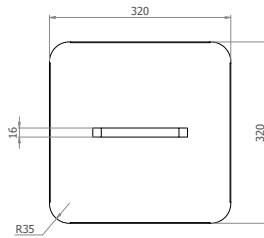

ICEL-303020

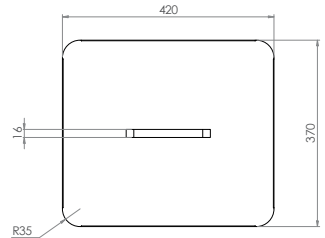

ICEL-403530

Side

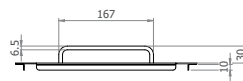

ICEL-303020

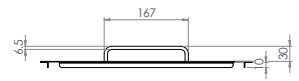

ICEL-403530

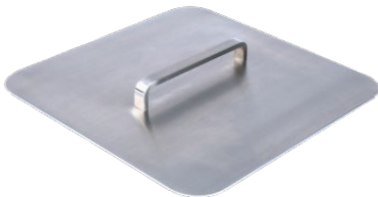

Under-side

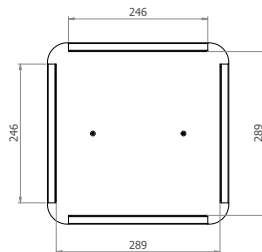

ICEL-303020

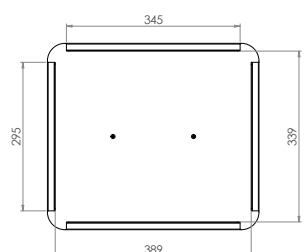

ICEL-403530

# Storage & Hardware



## Ice Well Removable Basket



### ICEB-303020

- Constructed from 1.2mm 304 grade stainless steel
- Includes Nylon Feet
- Suitable for pairing with ICE-303020 and ICEDI-303020

Top

ICEB-303020

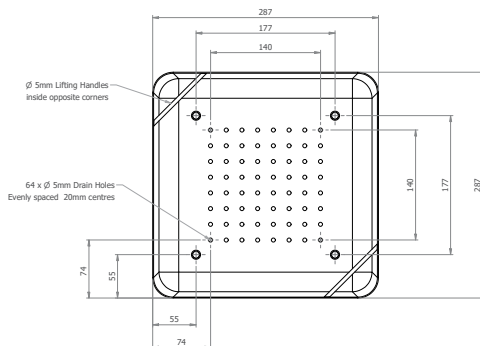

### ICEB-403530

- Constructed from 1.2mm 304 grade stainless steel
- Includes Nylon Feet
- Suitable for pairing with ICE-403530 and ICEDI-403530

Top

ICEB-403530

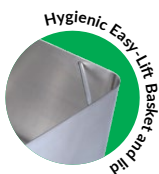
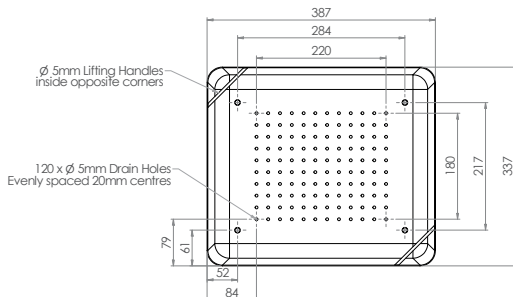

Side

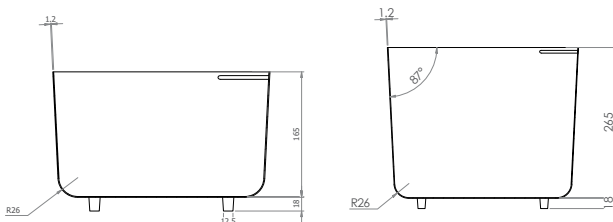

ICEB-303020

ICEB-403530

# Storage & Hardware



## Stainless Steel Adjustable Feet



- FH-10
- FH-11
- FH-12
- FH-13



304 Grade Stainless Steel Adjustable Disc Foot

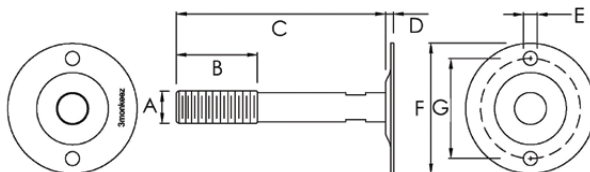

PRODUCT CODE	A	B	C	D	E	F	G	# OF HOLES
FH-10	16	41	105	4	7	65	50	2
FH-11	16	41	105	4	5	50	39	2
FH-12	16	41	70	4	5	50	39	2
FH-13	16	41	70	4	7	65	50	2

- FH-14



304 Grade Stainless Steel Adjustable Pin Foot

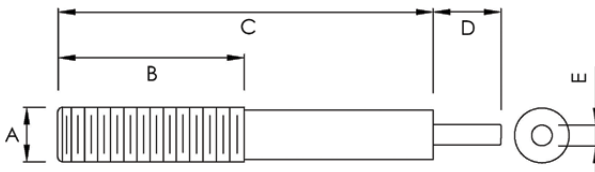

PRODUCT CODE	A	B	C	D	E
FH-14	16	55	110	20	6

- FH-15
- FH-16



304 Grade Stainless Steel Adjustable Lug Foot

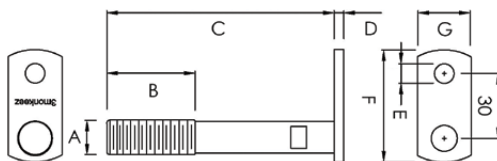

PRODUCT CODE	A	B	C	D	E	F	G	# OF HOLES
FH-15	16	41	70	4.5	9	52	25	1
FH-16	16	41	105	4.5	9	52	25	1

All measurements in mm.

# Storage & Hardware

## Nylon Leg Insert



FH-17

FH-18



Nylon Leg Insert - Square Tube

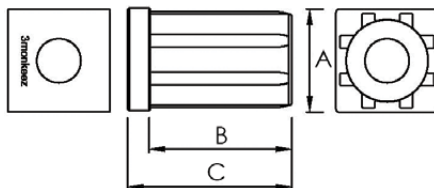

PRODUCT CODE	A	B	C	THREAD
FH-17	25	55	62	M16
FH-18	32	55	62	M16

FH-19



Nylon Leg Insert - Square Tube

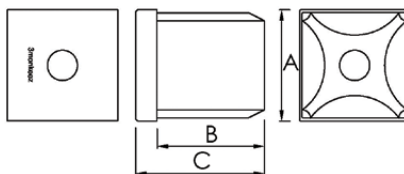

PRODUCT CODE	A	B	C	THREAD
FH-19	38	50	60	M16

FH-20



Nylon Leg Insert - Round Tube

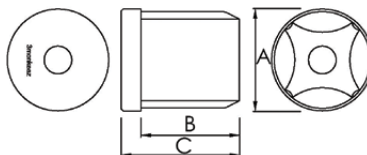

PRODUCT CODE	A	B	C	THREAD
FH-20	38	50	60	M16

To fit tube of 1.2mm or 1.6mm wall thickness.

All measurements in mm.

# Storage & Hardware

## Nylon Adjustable Feet



FH-21

FH-22

FH-23



Nylon Adjustable Foot - Square Tube

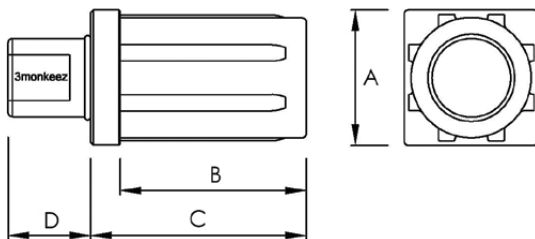

PRODUCT CODE	A	B	C	D	ADJ. HEIGHT
FH-21	25	33	40	14	20
FH-22	32	45	52	20	20
FH-23	38	45	52	25	20

FH-24

FH-25



Nylon Adjustable Foot - Round Tube

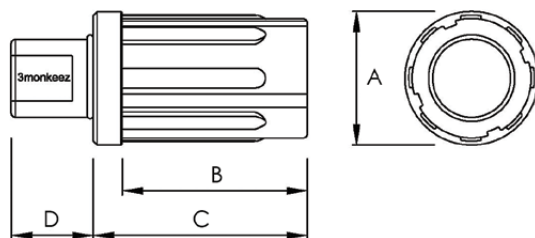

PRODUCT CODE	A	B	C	D	ADJ. HEIGHT
FH-24	38	45	52	25	20
FH-25	50	55	65	26	30

To fit tube of 1.2mm or 1.6mm wall thickness.

All measurements in mm.

# Storage & Hardware

## Adjustable Feet



FH-26  
FH-27



Zinc Die-Cast Chrome Plated Adjustable Hex Foot - Square Tube

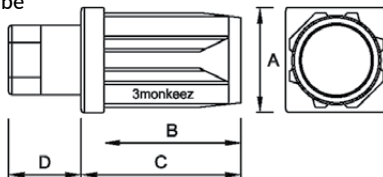

PRODUCT CODE	A	B	C	D	ADJ. HEIGHT
FH-26	25	32	37	10	25
FH-27	32	43	50	23	33

FH-29  
FH-30



Zinc Die-Cast Chrome Plated Adjustable Flanged Foot - Square Tube

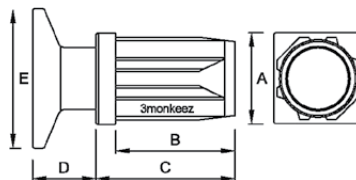

PRODUCT CODE	A	B	C	D	E	ADJ. HEIGHT
FH-29	25	32	37	10	30	25
FH-30	32	43	50	23	50	33

FH-31  
FH-32



304 Grade Stainless Steel Clad Adjustable Hex Foot - Round Tube

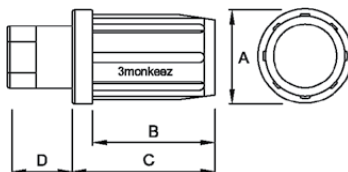

PRODUCT CODE	A	B	C	D	ADJ. HEIGHT
FH-31	38 *	43	51	24	33
FH-32	50 *	46	56	28	35

\* This represents tube size. To fit tube of 1.2mm or 1.6mm wall thickness. All measurements in mm.

# Storage & Hardware

## Plastic Tube Closures



- FH-33
- FH-34
- FH-35
- FH-36
- FH-37

Plastic Tube Closure - Square Tube

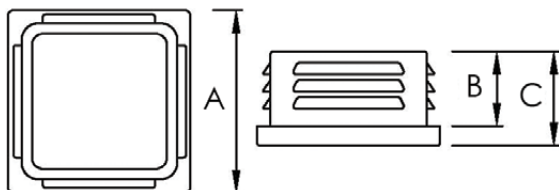

PRODUCT CODE	A	B	C
FH-33	19	13	16.5
FH-34	25	13	16.5
FH-35	32	13	16.5
FH-36	38	13	16.5
FH-37	50	13	16.5

- FH-38
- FH-39
- FH-40
- FH-37R

Plastic Tube Closure - Round Tube

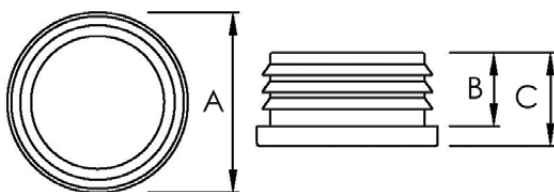

PRODUCT CODE	A	B	C
FH-38	25	13	16.5
FH-39	32	13	16.5
FH-40	38	13	16.5
FH-37R	50	13	16.5

To fit tube of 1.2mm or 1.6mm wall thickness.  
All measurements in mm.

# Storage & Hardware



## Drawer Handles & Pulls



FH-41



Flush Mount Type (Weld In)

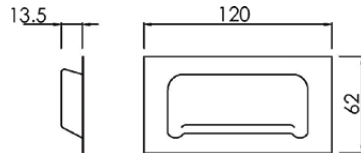

FH-43



Bevelled Edge With Fixing Studs

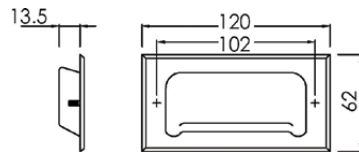

FH-44



With Grip Flush Mount Type (Weld In)

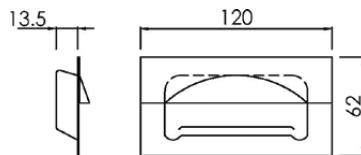

FH-45



120mm Diameter With Grip and Fixing Studs

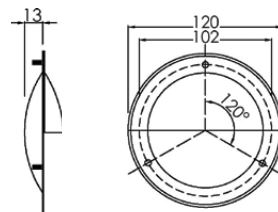

All products are made from 0.6mm Stainless Steel. No. 4 Brush Finish.



# Storage & Hardware

## Stainless Steel Adjustable Leg & Mounting Plate



### FH-46-S/S

(O/A Height 124mm - 153mm)

### FH-46-Z/P

(O/A Height 124mm - 153mm)

### FH-47-S/S

(O/A Height 150mm - 177mm)

### FH-47-Z/P

(O/A Height 150mm - 177mm)

### FH-48-S/S

(O/A Height 198mm - 227mm)

### FH-48-Z/P

(O/A Height 198mm - 227mm)

### FH-49-S/S

(O/A Height 249mm - 277mm)

### FH-49-Z/P

(O/A Height 249mm - 277mm)



FH-50 (Stainless Steel)

FH-51 (Zinc Plated)



### Adjustable Leg - Round Tube

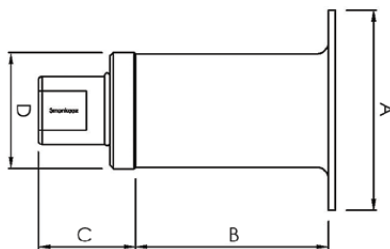

PRODUCT CODE	A	B	C	D	MOUNTING PLATE
FH-46-S/S	88	85	36	50	FH-50
FH-46-Z/P	88	85	36	50	FH-51
FH-47-S/S	88	110	36	50	FH-50
FH-47-Z/P	88	110	36	50	FH-51
FH-48-S/S	88	160	36	50	FH-50
FH-48-Z/P	88	160	36	50	FH-51
FH-49-S/S	88	210	36	50	FH-50
FH-49-Z/P	88	210	36	50	FH-51

### Mounting Plate

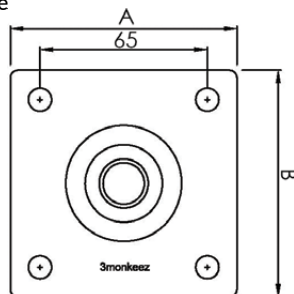

PRODUCT CODE	A	B	THICKNESS	HOLE	# OF HOLES
FH-50	88	88	3	9	4
FH-51	88	88	3	9	4

S/S = Stainless Steel Z/P = Zinc Plated

All measurements in mm.

# Storage & Hardware



## Stainless Steel Hinges



FH-55  
FH-56-LH  
FH-57-RH



304 Grade Stainless Steel Flag Hinge

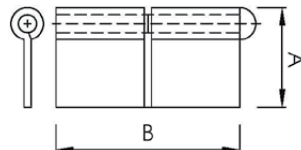

PRODUCT CODE	A	B	THICKNESS	PIN
FH-55	28	52	2	4.8
FH-56-LH	50	75	2	4.8
FH-57-RH	50	75	2	4.8

FH-58-LH      FH-59-RH  
FH-60-LH      FH-61-RH



304 Grade Stainless Steel Lift Off Hinge

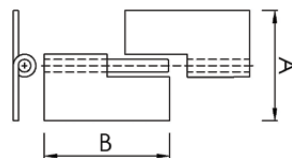

PRODUCT CODE	A	B	THICKNESS	PIN
FH-58-LH	44	50	2	4
FH-59-RH	44	50	2	4
FH-60-LH	50	76	2	4
FH-61-RH	50	76	2	4

FH-62      FH-63  
FH-64      FH-65  
FH-66      FH-67  
FH-68      FH-69



304 Grade Stainless Steel Continuous Hinge

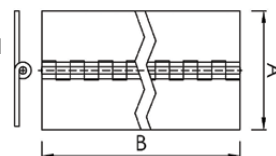

PRODUCT CODE	A	B	THICKNESS	PIN
FH-62	27	1800	0.9	3
FH-63	32	1800	1.2	3
FH-64	38	1800	1.2	3
FH-65	50	1800	1.2	3
FH-66	57	1800	1.5	4.5
FH-67	63	1800	1.5	4.5
FH-68	76	2160	1.5	4.5
FH-69	127	2000	1.5	4.5

All measurements in mm.

# Storage & Hardware

## Utility Lock



FH-71



Polished Chrome Utility Lock

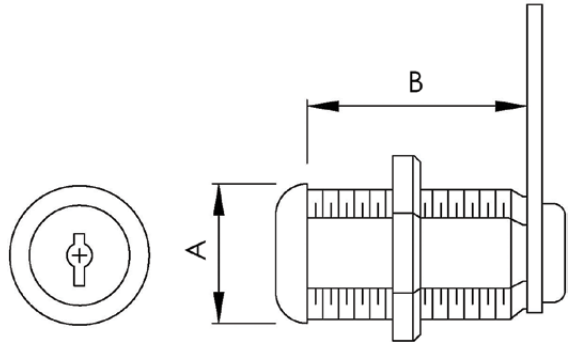

FH-72



PRODUCT CODE	A (mm)	B (mm)
FH-71	22	22
FH-72	22	28
FH-73	22	35

FH-73





NSW 02 9627 6111

VIC 03 9357 6562

QLD 07 3881 0322

WA 08 6305 0681

SA 0408 299 443

ACT 0408 446 961

TAS 03 6344 7060

NT 0447 382 658

FNQ 07 4775 6956

**3monkeez**

[www.3monkeez.com.au](http://www.3monkeez.com.au)

[sales@3monkeez.com.au](mailto:sales@3monkeez.com.au)