

Elephant Plasterboard
QuickBrace Systems Manual
July 2015



Elephant
QUICKBRACE
SYSTEMS

www.elephantplasterboard.co.nz



Elephant
Plasterboard

STRENGTH WITH STYLE

Elephant Plasterboard Bracing Systems Publications

These publications are continuously being updated and superseded. It is important to check to ensure you have the latest publication. Call Free Helpline 0800 ELEPHANT (353742).

Elephant Plasterboard Product System Warrantee

Elephant Plasterboard wall and ceiling linings are supported by Elephant Plasterboard's Quality Guarantee. Elephant Plasterboard supplies products which are warranted to be free from defects. Any products found to be defective before or after installation will be replaced and/or repaired, provided installation has been in accordance with Elephant Plasterboard's technical literature.

Elephant Plasterboard QuickBrace Systems

Liability for systems that are not designed and installed in accordance with this publication will not be accepted by Elephant Plasterboard (NZ) Limited.

Substitution

If Elephant Plasterboard QuickBrace™ systems have been selected at design stage, it is important to note that these systems may not be substitutable by other plasterboard systems. All components, framing design, fixing layout and fasteners details must be strictly adhered to in order to ensure the performance of the systems originally specified.

Copyright

All the material in this document including text, diagrams, figures, patterns, drawings and tables are protected by Copyright. This includes the Elephant Quickbrace Numbering System and the sub-components thereof.

Elephant Plasterboard (NZ) Limited Trademarks:

Elephant Plasterboard, Elephant Gypsum Board,
Elephant Board, Elephant Standard Plasterboard,
Elephant Superboard, Elephant Multiboard,
Elephant Fireboard, Elephant Braceboard,
Elephant Aquaboard, Elephant Smartboard,
Elephant Standard-Plus, Elephant Noiseboard,
Elephant Impactboard, Elephant Ultraboard

Free Helpline

0800 ELEPHANT (353-742).

Email

info@elephantpb.co.nz

Website

www.elephantplasterboard.co.nz

Telephone

(09) 818-7706

Facsimile

(09) 818-7702

Elephant Plasterboard (NZ) Limited
P.O. Box 21-436, Waitakere 0650
New Zealand



This document was printed in New Zealand using soy based ink and Elemental-Chlorine-Free recycled paper from a mill that is ISO 9002 certified.



Contents

4	Introduction
	Recent Changes
	Elephant Plasterboard Bracing Design Solutions
	Compliance to NZS 3604:2011
5-11	Design Instructions
13	Design Solutions
	QuickBrace™ Numbering System
	QuickBrace™ Systems & Performance Table
14-17	Manual Solution Method
14	Wall Bracing Design Sheet One
15	Wall Bracing Design Sheet Two
16	Wall Bracing Solution Sheet: Along
17	Wall Bracing Solution Sheet: Across
18-22	Wall and Ceiling Construction Details
18	Framing
18	Fastening Bracing Elements to Floors
18	Top Plate Connections
18-19	Panel End Hold Down Details
19	Intersecting Walls
19	Parapets gable end walls or drop suspended ceilings
20-21	Ceiling Diaphragms
22	Wall Bracing Construction Details
22	Fastening the Plasterboard Linings
22	Fastener Layout
22	Minimum Sheet Size
22	Butt Joints
22	Horizontal Fixing
22	Wet Areas
22	Openings in Bracing Elements
22	Plywood Fixing
23-25	Bracing System Specification Sheets
23	Plasterboard One Side
24	Plasterboard Both Sides
25	Plasterboard One Side, Plywood the Other
27	Product Range Table and Specification Guide



Introduction

Elephant Plasterboard QuickBrace™ Systems

Extensive bracing tests have been conducted on Elephant Plasterboard. The Bracing ratings published in this document have been obtained by independent testing and opinions sourced from New Zealand organizations with accredited quality assurance. Detailed in this document are some unique design solutions now available to the New Zealand Building Industry to satisfy the bracing requirements of the New Zealand Standard NZS 3604:2011 Timber framed buildings.

Recent changes

We have made changes and improvements to the QuickBrace™ Systems.

• Revised Specification Numbering System

The numbering system has changed slightly to make it easier for the builder or building official to know which systems require Panel End Hold-downs (H) or not (N). The code "H" and the code "N" have been moved to the end of the numbering system. For example, the code ENSS has been changed to ESSN.

Furthermore a "-" has been incorporated into some codes to indicate single-sided systems. For example, the code ESN would now be ES-N.

• Enhanced QuickBrace™ Software

There have been a number of significant changes and enhancements to the QuickBrace™ Software.

In particular, the software now allows designers and engineers to calculate the demands and complete the bracing design in either kilonewtons (kN) or Bracing units (BU).

A number of other enhanced features will further assist designers and engineers, to not only comply to the rules of NZS 3604:2011 but also assist in good design and construction.

The new software can be downloaded from www.elephantplasterboard.co.nz or by emailing info@elephantpb.co.nz to request a copy.

• Revised Performances

Further on going testing using the new BRANZ P21 (2010) Test Methodology have provided revised performances.

• Bottom Plate Anchor Placements

Bottom plate anchor placements have been reduced from 100mm to 80mm from the end of the bracing element. This is to be consistent with the bolt location when using bracing anchor brackets and represents industry best practise. This does not affect previous bracing designs or installations or performances.

• Changed Corner Pattern

In order to reduce the number of different bracing corner patterns we have replaced our "Typical" Bracing Corner Pattern to our "Condensed" Bracing Corner Pattern. This replaced pattern applies to all QuickBrace™ Systems including the ES-N and the ESSN. This does not affect previous bracing designs or installations or performances.

• Independently Appraised

All tests, opinions and re-evaluated performances have been fully Appraised by Independent Consulting Engineers.

Elephant Plasterboard Bracing Design Solutions

System Number	Lining Requirement	Additional Bottom Plate Fixing	Bracing Corner Pattern
Plasterboard on One side			
ES-N	Elephant Standard-Plus on one side	None	Condensed
ES-H	Elephant Standard-Plus on one side	Panel End Hold-downs	
EM-H	Elephant Multiboard on one side		
Plasterboard on Both Sides			
ESSN	Elephant Standard-Plus on both sides	None	Condensed
ESSH	Elephant Standard-Plus on both sides	Panel End Hold-downs	
EMSH	Elephant Multiboard on one side, Standard-Plus on the other		
Plasterboard One side, Plywood the Other			
ESPH	Elephant Standard-Plus on one side, Plywood on the other	Panel End Hold-downs	Condensed
EMPH	Elephant Multiboard on one side, Plywood on the other		

Compliance to NZS 3604:2011

The Elephant QuickBrace™ Systems detailed in this document and the Elephant QuickBrace™ Software are fully compliant to the requirements of NZS 3604:2011 Timber-framed buildings. Design and installation must be in accordance with this document.



Design Instructions

DESIGN STEPS

- One: Determine and Record the Project Specifications**
- Two: Determine and Record the Wind and Earthquake Zones**
- Three: Calculate the Bracing Demand for Wind and Earthquake**
- Four: Distribute Bracing Lines and Bracing Elements as evenly as possible**
- Five: Ensure Individual Bracing Line Totals exceed the Individual Bracing Line Demand**
- Six: Ensure Total Bracing Achieved exceeds Total Bracing Demand for both Wind & Earthquake**

Electronic Method

We recommend the use of the Elephant Quickbrace Software. This can be downloaded from www.elephantplasterboard.co.nz or requested by emailing info@elephantpb.co.nz.

This powerful tool will perform a number of important functions.

1. The determining and recording of the Project Specifications. It will provide numerous warnings and comments to assist with entering correct parameters.
2. The determining of the Wind and the Earthquake Zone and other Earthquake requirements.
3. Once Project specifications have been entered and Wind and Earthquake Zones determined then the software will automatically calculate the Wind Along and Wind Across Demand and the Earthquake Demand.
4. The placing of selected proprietary bracing systems on bracing lines on the plan must be done manually and in conjunction with the recording on the individual solution sheets for the Along and Across direction for each level of the project.
5. Provide warnings if minimum line demand requirements are not met for both External and Internal bracing lines.
6. Provide warnings if total bracing demand has not been achieved for either Wind or Earthquake.

The tool provides many other helpful warnings and suggestions in order to ensure good design and reduce the likelihood of non-compliance with the requirements of NZS 3604:2011.

Manual Method

Complete pages 14-17 using design step guidelines below.

Design Step One: Determine and Record the Project Specifications

Wall Heights

Electronic Method: To assist in determining wall heights and project dimensions refer to the figures on page 6.

Manual Method: When referring to the tables 5.5, 5.6 and 5.7 in NZS 3604:2011 It is important to consider the following.

Subfloors:	Height to apex is the average ground level to the apex
Lower Level of two Storeys:	Height to apex is the lower floor level to the apex
Upper Level or Single Level:	Height to apex is the upper or single floor level to the apex

Building Widths and Lengths

Electronic Method: Use actual building width and building length regardless of roof pitch.

Manual Method: If the roof pitch is greater than 25 degrees use roof length and width instead of building length and width when calculating total bracing demands.

External Cladding and Roof Cladding Weights

Electronic Method: Specific Cladding Weights can also be entered.

Wall and Subfloor Cladding Weights			
Wall Cladding Class	Light	Medium	Heavy
Weight (Kg/m ²)	≤30	>30 to 80	>80 to 220

Roof Cladding Weights		
Roof Cladding Class	Light	Heavy
Weight (Kg/m ²)	≤20	>20 to 60



Design Instructions

Guides to Heights and Dimensions

Manual Method: Use Wall Heights from individual floor levels to apex when using the tables in Section 5 of NZS 3604:2011. Also consider the rules regarding the use of the building length and width once the roof pitch is over 25 degrees. (See notes on previous page).

Electronic and Manual Method: All other height and dimension guides set out below can be used.

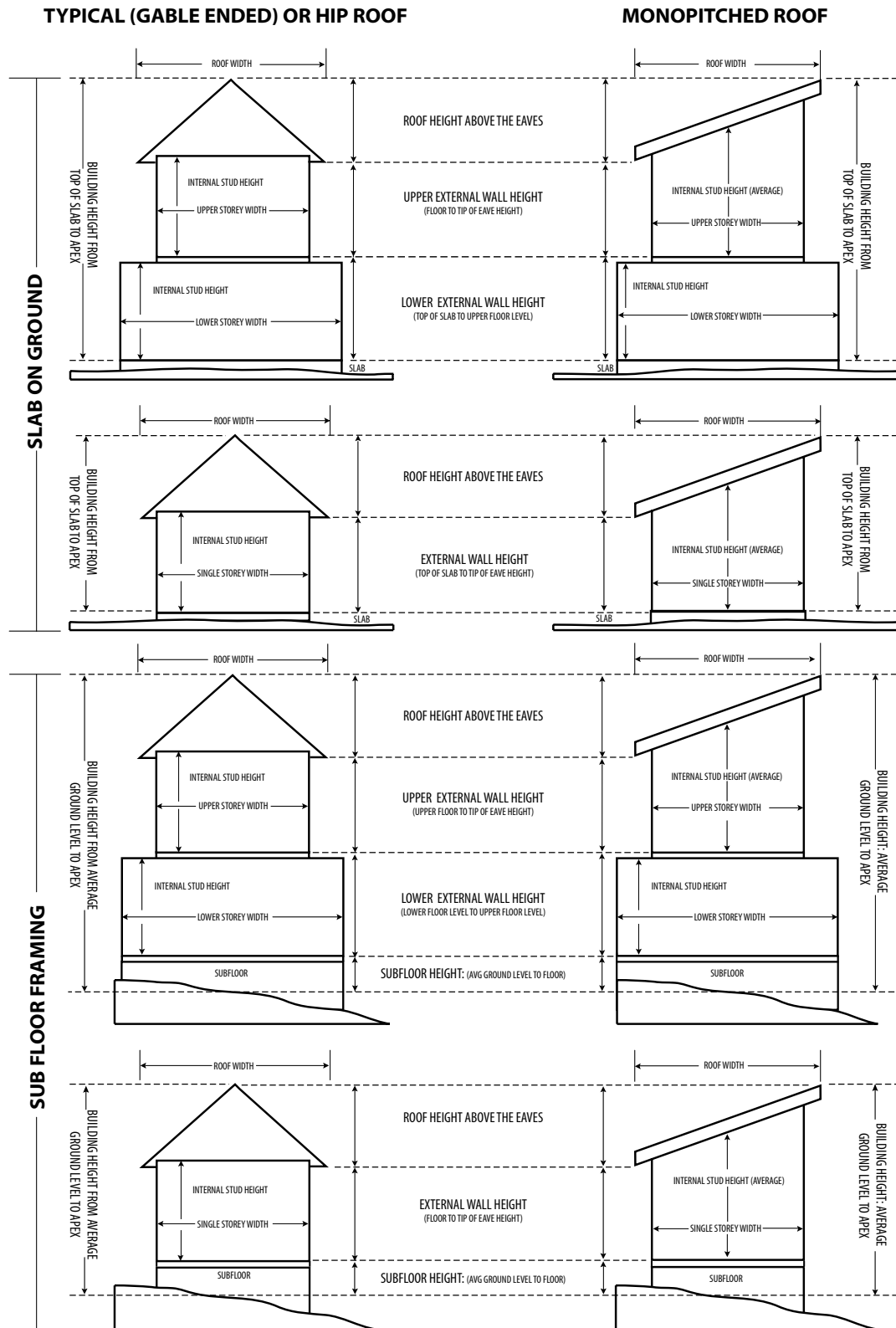

Design Instructions

Design Step Two: Determine and Record The Wind and Earthquake Zones

For detailed information consult NZS 3604:2011. Section 5

Determine Wind Zone

Consult your local Building Consent Authority as they may have prepared Wind Zone Maps. These should be used as a guide only. For a more accurate determination of Wind Zone follow the steps in NZS 3604:2011 Table 5.1 and the guidelines detailed below.

Wind Steps	Determine	Select One of the following	NZS 3604:2011 Guide
1	Topographic Class	T1, T2, T3 or T4	Section 5.2.5 and Page 7 of this Manual
2	Site Exposure	Sheltered or Exposed	Section 5.2.4 and Page 8 of this Manual
3	Ground Roughness	Urban or Open	Section 5.2.3 and Page 8 of this Manual
4	Wind Region	A or W	Figure 5.1
5	Lee Zone	Yes or No	Figure 5.1
6	Wind Zone	Low, Medium, High, Very High, Extra High or SD	Table 5.4

Wind Step 1: Determine Topographic Class:

To determine the topographic class for the site. Refer to clause 5.2.5 in NZS 3604:2011 and the following guide notes and tables.

Topo Steps	Determine	Select from the following	Reference
1	Determine Topography	Hill or Escarpment	Refer Topography figure below
2	Hill Height	H	Refer Topography figure below
3	Smoothed gradient value and slope	Gentle, Low, Mild, Moderate or Steep	Refer Topography figure below
4	Topographic Zone	Crest Zone, Outer Zone or Outside the Zone	Refer Topographic figure below
5	Topographic Class	T1, T2, T3 or T4	Refer Topographic Class table below

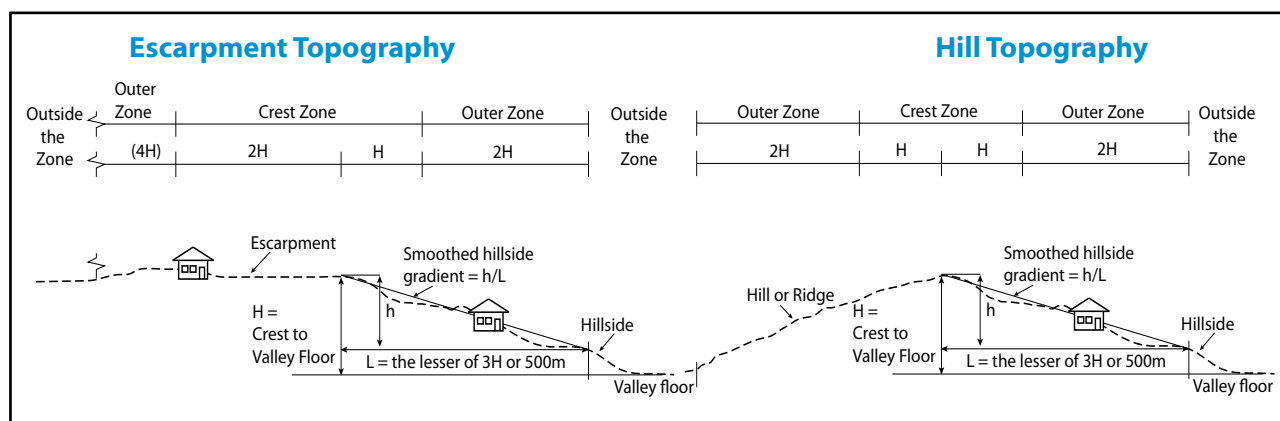

Topographic Class Table:

	Gentle	Low	Mild	Moderate	Steep	Undulations Under 10m on any Slope (Gradient)
Smoothed Hillside Gradient (h/L)=	≤ 0.05	> 0.05 to 0.1	> 0.1 to 0.15	>0.15 to 0.2	>0.2	
Slope =	≤1:20	>1:20 to 1:10	>1:10 to 1:6.7	>1:6.7 to 1:5	>1:5	
TOPOGRAPHY						
Outside the Zones	T1	T1	T1	T1	T1	T1
Outer Zone	T1	T1	T2	T2	T3	T1
Crest Zone	T1	T2	T3	T4	T4	T1
Known Accelerated Wind Flow	T4	T4	T4	T4	T4	T4



Design Instructions

Wind Step 2: Determine Site Exposure

When determining the site exposure, consider the wind shielding effects of objects around the site.

- Exposed:** Sites are deemed Exposed if they have **any** of the following conditions:
- Steep sites as defined in table 5.2 and Section 5.2.3 in NZS 3604:2011
 - Sites adjacent to open spaces. For example, beach fronts, motorways, large rivers, or playing fields etc
 - Sites adjacent to wind channels whose width is greater than 100m
 - Sites that do not have at least 2 rows of permanent structures (of similar size) all around and at the same ground level

- Sheltered:** Sites can only be deemed Sheltered if they have **both** of the following conditions:
- The site does not have any of the conditions described above
 - The site has at least 2 rows of permanent structures (of similar size) all around & at the same ground level

Wind Step 3: Determine Ground Roughness

If the building site is on Open Terrain (as described below) or within 500m in any direction of an area determined to be Open Terrain, then the Ground Roughness is determined to be OPEN.

If the building site is on Urban terrain (as described below) or NOT within 500m in any direction of an area determined as Open Terrain, then the Ground Roughness is determined to be URBAN.

- Open Terrain:** Terrain is deemed "Open" if it has **any** of the following conditions;
- Areas that are open farmland (grazed pastures or croplands).
 - Areas with isolated trees or shelter.
 - Areas Adjacent to Coastlines or Large Lakes.
 - Areas Adjacent to Airfields etc.

- Urban Terrain:** Terrain is deemed "Urban" if it has **both** of the following conditions;
- It has more than 10 obstructions, houses, trees etc (3m high) per hectare.
 - AND NOT Adjacent to Coastlines Large Lakes or Airfields etc.

Wind Step 4 and 5: Determine Wind Region & Lee Zones

Figure 5.1 from NZS 3601:2011 gives the wind region. Lee zones are shaded and attract higher wind speeds resulting in a higher design wind zone as given in Table 5.4.

Wind Step 6: Determination of Wind Zone

Electronic Method: The Elephant QuickBrace™ software determines the Wind Zone automatically once these parameters have been entered. Furthermore a specific wind speed can be entered if known.

Manual Method: Once Wind Steps 1 to 5 have been completed, the Wind Zone can be determined from referring to table below.

Wind Zone Table		TOPOGRAPHIC CLASS							
		T1 (Gentle)		T2 (Moderate)		T3 (Significant)		T4 (Extreme)	
Wind Region	Ground Roughness	-----SITE EXPOSURE-----							
		Sheltered	Exposed	Sheltered	Exposed	Sheltered	Exposed	Sheltered	Exposed
A	Urban	L	M	M	H	H	H	H	VH
	Open	M	H	H	VH	H	VH	VH	EH
W	Urban	M	H	H	VH	H	VH	EH	EH
	Open	H	VH	VH	EH	VH	EH	SD	SD

Note: Projects in Lee Zones shall have their Wind Zones increased as follows:

- Low wind becomes High,
- Medium wind becomes Very High
- High wind or above becomes Specific Design

Wind Zone	L=Low	M=Medium	H=High	VH=Very High	EH=Extra High	SD=Specific Engineering Design
Maximum ultimate limit state Wind Speed	≤32 m/s	≤37 m/s	≤44 m/s	≤50 m/s	≤55 m/s	Speeds > 55 m/s are not covered by NZS 3604:2011



Design Instructions

Design Step Two continued.....

Determine Earthquake Zones and other additional Earthquake multipliers

Earthquake Steps	Determine	Select one of the following	NZS 3604:2011 guide or reference
1	Earthquake Zone	1,2,3 or 4	Figure 5.4
2	Site Subsoil Classification	A,B,C,D or E	Territorial Authorities or SED
3	Floor Loads	2 kPa, 3 kPa or other	
4	Room in Roof space	Yes or No	Building Plan
5	Annual Exceedance Probability	1/500 yrs, 1/1000 yrs or 1/2500 yrs	

Earthquake Step 1: Determine Earthquake Zone

Earthquake Zones are 1, 2, 3 or 4. Refer to figure 5.4 NZS 3604:2011 section 5.

Earthquake Step 2: Determine Site Subsoil Classification

Site subsoil classifications can be obtained from your local territorial authority or GNS science QMAPS available from their GNS website and can be one of the following:

- Class A -Strong Rock
- Class B- Rock
- Class C- Shallow soil
- Class D- Deep or soft soil
- Class E- Very soft soil

If subsoil information is not available then determine the subsoil class as Class E (very soft soil) unless specific engineering design is conducted.

Earthquake Step 3: Determine Floor Loads

These are commonly either 2 kPa or 3 kPa. (NB. Specific floor loads can be entered in the QuickBrace™ Software.)

Earthquake Step 4: Determine if Room in Roof Space

Refer to building plan.

Bracing demands for Earthquake increase as a factor of the room area in the roof space. If the floor area of the room in roof space exceeds 50% of the floor area of the storey below it, then it should be regarded as another storey.

Earthquake Step 5: Determine Annual Exceedance Probability

The NZS 3604:2011 default annual exceedance probability for Earthquake is 1 in 500 years (factor 1.0) however designers may wish to increase the annual exceedance probability to 1 in 1000 years (factor 1.3) or 1 in 2500 years (factor 1.8) depending on building use or client requirements.

Design Step Three: Calculate the Bracing Demand for Wind and Earthquake

Calculating Wind Demand Across and Wind Demand Along

Electronic Method: The Elephant QuickBrace™ software will automatically calculate the Wind Demand for the Along and Across direction for each level of the project.

Manual Method: Refer to tables 5.5, 5.6 and 5.7 of NZS 3604:2011 section 5 to obtain the Wind Across values and Wind Along values (demands per lineal meter of wall length). The table is based on projects in a High Wind Zone. These values will need to have a factor applied to them for projects in other Wind Zones as follows;

Wind Zone	Factor
Low	0.5
Medium	0.7
High	1.0
Very High	1.3
Extra High	1.6

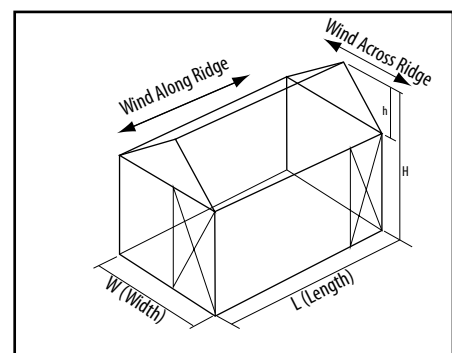

Once the Wind Across values and the Wind Along values have been obtained from the relevant tables in NZS 3604:2011 for each floor level;

- The Wind Demand Across is calculated by multiplying the Wind Across values by the building Length (BL) of that floor level.
- The Wind Demand Along is calculated by multiplying the Wind Along values by the building Width (BW) of that floor level.
- For projects with Monopitched roofs use the higher of the Wind Across value or the Wind Along value (from the tables) when multiplying by the building Length or building Width (as is appropriate).
- For projects with a Hip roof use only the Wind Across values from the table when calculating the Wind Demand Across and Wind Demand Along.



Design Instructions

Calculate Earthquake Demand

Electronic Method:

The Elephant QuickBrace™ software will automatically calculate the Earthquake Demand for each level of the Project.

Manual Method:

Refer to NZS 3604:2011 tables 5.8, 5.9, 5.10, section 5. (If floor load 3kPa refer to tables 14.1, 14.2, 14.3 section 14)

Once the Earthquake values (per square meter of floor area) has been obtained from the relevant tables for each floor level;

- The Earthquake Demand is calculated by multiplying that value (from the relevant table) by the Gross Plan Area (GPA) of that floor level.
- For structures with a Room in the roof space, add 4 BUs to the Earthquake value (from the relevant table) before multiplying that value by the GPA of that floor level.

Design Step Four: Distribute Bracing Lines and Bracing Elements as evenly as possible.

Bracing Lines should be distributed as evenly possible throughout the building.

Individual bracing lines shall be no closer than 1m apart and no more than 6m apart. Bracing lines may be 7.5m apart where dragon ties are used as per figure 8.1 in NZS 3601:2011.

Walls more than 2m apart must be on separate bracing lines.

Locate Bracing Elements as close as possible to the corners of external walls and as evenly as possible throughout the building. It is also important to distribute bracing elements on each individual bracing line as evenly as possible.

Wings extending more than 6m from the main building shall have their bracing requirements calculated and designed separately.

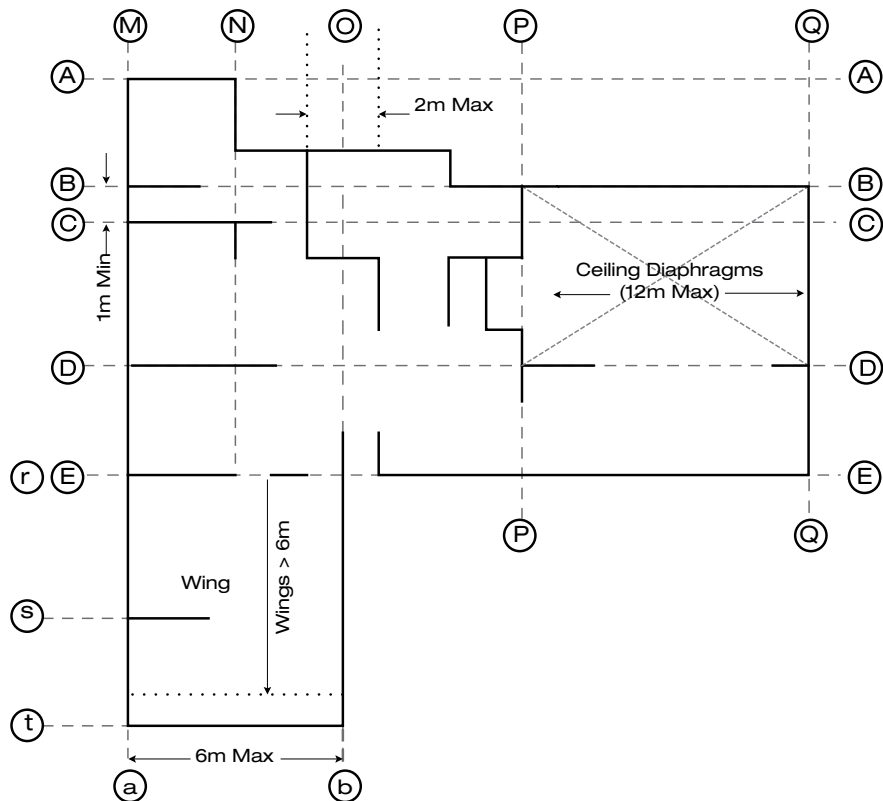

Design Step Five: Ensure Individual Bracing Line Totals exceed the Individual Bracing Line Demand

Choose the QuickBrace™ systems from the QuickBrace™ performance table (Page 13) in order to achieve the number of bracing units required in total and per External and Internal Line demand.

Note- It is important to complete both Wind and Earthquake columns because the Minimum Bracing Units required in each individual line label must be met by both the Wind and Earthquake performance totals achieved for that line label.

Brace units achieved on any line, shall not have a rating less than the greater of:

- Either 50% of the total bracing demand, divided by the number of bracing lines;
- Or 100 BUs.

For example, if the demand for bracing for the project is 900 BUs (Wind) and 600 BUs (Earthquake) in the Along direction and there are three bracing lines (A, B and C) then each line minimum is $50\% \times 900 / 3 = 150$ BUs (Wind) and $50\% \times 600 / 3 = 100$ BUs (Earthquake).

Additionally all External Walls must have at least a bracing capacity of 15 BUs per metre of external wall length or 100 BUs which ever is the greater.



Design Instructions

Design Step Five Continued:

Manual Method Continued...

For each selected bracing element multiply the System Performance by the element length which will give the total bracing provided by that element for both Wind and Earthquake Performance.

E.g. 1.8m x ES-N = Wind 1.8m x 85 = 153 BUs
 Earthquake 1.8m x 70 = 126 BUs

Adjustment for wall height:

For wall heights greater than 2.4m, multiply the System Performance by 2.4 / Internal Stud Height.

E.g. If the published wind bracing rating is 100 BUs/m and the wall height is either 2.4, 2.7 or 3.0 m, then the adjusted wall rating is;
 100 x 2.4/2.4 = 100, 100 x 2.4/2.7 = 89, or 100 x 2.4/3.0 = 80 BUs/m respectively.

For wall heights lower than 2.4, use ratings at the 2.4m height.

Adjustment for wall angle:

For wall angles other than 0 Degrees multiply the System Performance by the Cosine of the Wall Angle to the bracing line direction

E.g. Cos 30° = 0.87, Cos 45° = 0.71, Cos 60° = 0.50

Note- For Wall Angles greater than 45 degrees, consider placing bracing elements on perpendicular line labels.

Design Step Six:

Ensure Total Bracing Achieved exceeds Total Bracing Demand for both Wind & Earthquake.

Once all individual bracing element performances have been calculated on each individual bracing line, add up the total Wind and Earthquake achieved (for both the Along and Across directions) and ensure they exceed the total bracing demand for both Wind and Earthquake for each relevant level.

Ceiling Diaphragms

Diaphragms are used to distribute horizontal loads.

Ceiling diaphragms are required to comply with Section 5.6 and 13.5 of NZS 3604:2011. Ceiling diaphragms are required when distances between bracing lines exceed 6m (when dragon ties not used) or 7.5m if dragon ties used as per figure 8.1 in NZS 3604:2011.

Refer also to page 20 of this document.

Ceiling diaphragms shall not exceed 12m in length and the length shall not exceed twice the width (both length and width being measured between supporting walls). The ceiling lining shall cover the entire area of the ceiling diaphragm.

Each Wall surrounding the Ceiling Diaphragm shall have a minimum bracing capacity of 15 BUs /Lm of wall length or 100 BUs whichever is the greater. Refer to the figure on the right.

Limitations for Ceiling Diaphragm Systems

Ceiling diaphragm requirements are dependent on the length of the room and/or the roof pitch.

- C1: Not steeper than 15 degrees and not longer than 7.5m
- C2: Not steeper than 25 degrees and not longer than 12m
 or Not steeper than 45 degrees and not longer than 7.5m

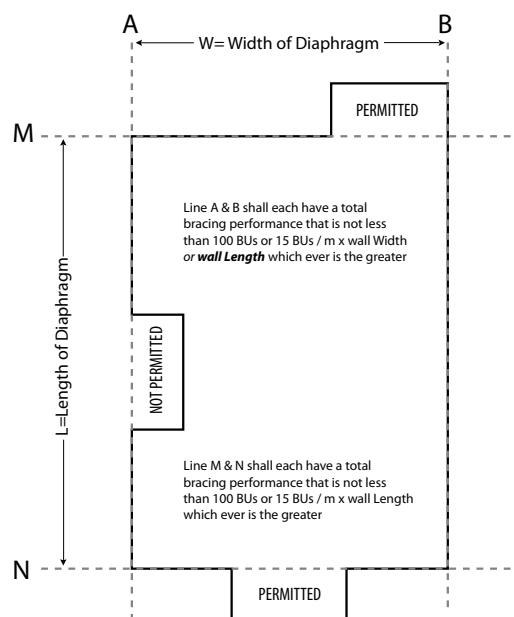

Quickbrace™ Design Solutions

Quickbrace™ Numbering System

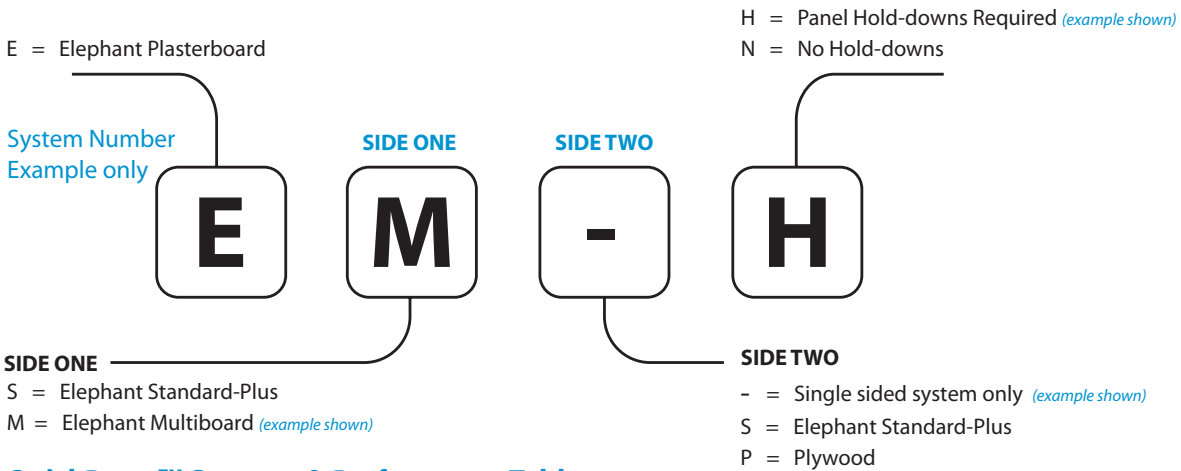

QuickBrace™ Systems & Performance Table

System Number	Lining Requirement	Min. Length (m)	BU/m		Panel Hold-downs	Bracing Corner Pattern
			Wind	Earthquake		
Plasterboard on One Side						
ES-N	Elephant Standard-Plus on One Side	0.4	65	60	No	Condensed
		1.2	70	65		
		1.8	80	65		
ES-H	Elephant Standard-Plus on One Side	0.4	80	75	Yes	
		0.8	100	85		
		1.8	115	85		
EM-H	Elephant Multiboard on One Side	0.4	95	100	Yes	
		0.8	120	110		
		1.2	140	115		
Plasterboard on Both Sides						
ESSN	Elephant Standard-Plus on Both Sides	0.4	80	75	No	
		0.8	90	80		
		1.2	95	85		
ESSH	Elephant Standard-Plus on Both Sides	0.4	95	110	Yes	
		0.8	140	130		
		1.2	150	140		
EMSH	Elephant Multiboard on One Side Elephant Standard-Plus on the Other	0.4	110	115	Yes	
		0.8	140	135		
		1.2	150	145		
Plasterboard One Side, Plywood the Other						
ESPH	Elephant Standard-Plus on One Side Plywood on the Other	0.4	100	115	Yes	
		0.8	140	140		
		1.2	150	150		
EMPH	Elephant Multiboard on One Side Plywood on the Other	0.4	120	135	Yes	
		0.8	140	145		
		1.2	150	150		

* Timber Floors - It is required by NZS 3604:2011 to limit BU ratings to 120 BU/m for timber floors. For a higher floor frame uplift, a specifically engineered design will be required.

Note- The QuickBrace™ Numbering System and the sub components thereof are protected by copyright.



Wall Bracing Design Sheet One

Manual Method

Design Step One: Determine and Record the Project Specifications

Please photocopy

Project Name	_____	Project Specifications	(tick where appropriate)
Street & Number	_____	Storey:	Single <input type="checkbox"/> Double <input type="checkbox"/>
Lot & DP Number	_____	Foundation Type:	Subfloor <input type="checkbox"/> Slab <input type="checkbox"/>
City/Town/District	_____	Single or Upper Floor Level to Apex	<input type="text"/> m
Designer Name	_____	Lower Floor Level to Apex (If Double storey)	<input type="text"/> m
Company Name	_____	Average Ground Level to Apex (If on Subfloor)	<input type="text"/> m
Engineers Name	_____	This Bracing Calculation completed by:	_____

Roof Details		Wall Details	Single/Upper Storey	Lower Storey	Subfloor
Height above Eaves (h)	<input type="text"/> m	Average Internal Stud Height	<input type="text"/> m	<input type="text"/> m	<input type="text"/> m
Roof Cladding	Light/Heavy	Wall Cladding	Light/Medium/Heavy	Light/Medium/Heavy	Light/Medium/Heavy
Average Roof Pitch (deg.)	<input type="text"/>	Building length (BL)	<input type="text"/> m	<input type="text"/> m	<input type="text"/> m
Part Storey in Roof Space	Yes or No	Building width (BW)	<input type="text"/> m	<input type="text"/> m	<input type="text"/> m
		Gross Plan Area (GPA)	<input type="text"/> m ²	<input type="text"/> m ²	<input type="text"/> m ²

NB. If the average roof pitch is over 25 degrees, use roof length and width to determine BL and BW

Design Step Two : Determine the Wind and Earthquake Zone

Wind Steps	Determine	Circle One of the following						Reference
1	Topographic Class	T1	T2	T3	T4		Page 7	
2	Site Exposure	Sheltered	Exposed					Page 8
3	Ground Roughness	Urban	Open					Page 8
4	Wind Region	A	W					Figure 5.1, NZS 3604:2011
5	Lee Zone	Yes	No					Figure 5.1, NZS 3604:2011
6	Wind Zone	Low	Medium	High	Very High	Extra High	SED	Table Below

Wind Zone Table

Wind Region	Ground Roughness	TOPOGRAPHIC CLASS							
		T1 (Gentle)		T2 (Moderate)		T3 (Significant)		T4 (Extreme)	
		-----SITE EXPOSURE-----							
		Sheltered	Exposed	Sheltered	Exposed	Sheltered	Exposed	Sheltered	Exposed
A	Urban	L	M	M	H	H	H	H	VH
	Open	M	H	H	VH	H	VH	VH	EH
W	Urban	M	H	H	VH	H	VH	EH	EH
	Open	H	VH	VH	EH	VH	EH	SD	SD

Projects in Lee Zones shall have their Wind Zones increased as follows: Low wind becomes High, Medium wind becomes Very High, High wind or above becomes Specific Design

Earthquake Zone

EQ Steps	Determine	Circle one of the following				Reference
1	Earthquake Zone	1	2	3	4	Figure 5.4, NZS 3604:2011
2	Site Subsoil classification	A or B	C	D	E	Territorial Authorities or SED
3	Floor Load	2 kPa	3 kPa			
4	Room in roof space	Yes	No			
5	Annual Exceedance probability	1/500 yrs (factor 1.0)	1/1000 yrs (factor 1.3)	1/2500 yrs (factor 1.8)		



Wall Bracing Design Sheet Two

Manual Method

Please photocopy

Design Step Three: Calculate the Bracing Demand for Wind and Earthquake

Once the Project Specifications and Wind Zone and Earthquake Zone have been determined from Steps One and Two, refer to Wind and Earthquake tables in NZS 3604:2011. Section 5 (and Section 14 if floor load is 3kPa), to complete Design Sheet Two.

Wind Tables (refer NZS 3604:2011 Section 5)		Earthquake Tables (refer NZS 3604:2011 Section 5)			
Level	Table	Floor Load =	2kPa		3kPa
Single or Upper Storey	5.6	Storeys =	Single	Double	Single Double
Lower Storey	5.7	Foundation Type	Table		Table
Sub Floor Structure	5.5	Subfloor Framing	5.8	5.9	14.1 14.2
		Slab on Ground	5.10	5.10	14.3 14.3

Single or Upper Level Wind Demand					
Refer Table 5.6					
Single or Upper Level Wind Along =				=	BU/s/m
Single or Upper Level Wind Across =				=	BU/s/m
WIND ALONG					
	BW		W ALONG		
Single or Upper Level		X		=	BU/s
WIND ACROSS					
	BL		W ACROSS		
Single or Upper Level		X		=	BU/s

Single Or Upper Level Earthquake Demand					
If Subfloor refer Table 5.8 If Slab refer table 5.10					
Single or Upper Level Earthquake (E) =				=	BU/s/sqm
Note: For part storey in roof space add E + 4					
EQ ALONG and EQ ACROSS:					
	GPA		E		
Single or Upper Level		X		=	BU/s

Lower Level Wind Demand					
Refer Table 5.7					
Lower Level Wind Along =				=	BU/s/m
Lower Level Wind Across =				=	BU/s/m
WIND ALONG					
	BW		W ALONG		
Lower Level		X		=	BU/s
WIND ACROSS					
	BL		W ACROSS		
Lower Level		X		=	BU/s

Lower Level Earthquake Demand					
If Subfloor refer Table 5.9 If Slab refer table 5.10					
Lower Level Earthquake (E) =				=	BU/s/sqm
Note: For part storey in roof space add E + 4					
EQ ALONG and EQ ACROSS:					
	GPA		E		
Lower Level		X		=	BU/s

Sub Floor Level Wind Demand					
Refer Table 5.5					
Sub Floor Level Wind Along =				=	BU/s/m
Sub Floor Level Wind Across =				=	BU/s/m
WIND ALONG					
	BW		W ALONG		
Sub Floor Level		X		=	BU/s
WIND ACROSS					
	BL		W ACROSS		
Sub Floor Level		X		=	BU/s

Sub Floor Level Earthquake Demand					
If Single Storey refer Table 5.8 If Double Storey refer table 5.9					
Sub Floor Level Earthquake (E) =				=	BU/s/sqm
Note: For part storey in roof space add E + 4					
EQ ALONG and EQ ACROSS:					
	GPA		E		
Sub Floor Level		X		=	BU/s

Transfer Results to appropriate Solution Sheets overleaf

Design Step Four: Distribute Bracing Lines and Bracing Elements as evenly as possible.

Design Step Five: Ensure Individual Bracing Line Totals exceed the Individual Bracing Line Demand. (See Sheet Overleaf)

Design Step Six: Ensure Total Bracing Achieved exceeds Bracing Demand for both Wind & Earthquake. (See Sheet Overleaf)



Wall Bracing Solution Sheet: Along

Manual Method

Please photocopy for each level

Project Name <input style="width: 250px;" type="text"/>							Storey Level <input style="width: 100px;" type="text"/>				
Along							(Single, Upper, Lower or Sub-Floor)				
Wall Bracing Line							Wind		Earthquake		
1	2	3	4	5	6	7	W8	W9	E8	E9	
Line Label	Bracing Element No.	Supplier	System Number	Element Length	Stud Height	Wall Angle	Rating BU/m	Achieved BUs	Rating BU/m	Achieved BUs	
A											
Minimum BUs Required for Line =							Line Sub-Total =				
B											
Minimum BUs Required for Line =							Line Sub-Total =				
C											
Minimum BUs Required for Line =							Line Sub-Total =				
D											
Minimum BUs Required for Line =							Line Sub-Total =				
E											
Minimum BUs Required for Line =							Line Sub-Total =				
F											
Minimum BUs Required for Line =							Line Sub-Total =				
G											
Minimum BUs Required for Line =							Line Sub-Total =				
							Wind	Earthquake			
							Along BUs Achieved =	<input style="width: 50px;" type="text"/>	OK?		
									OK?		
							From Sheet Two Along BUs Required =	<input style="width: 50px;" type="text"/>			



Wall Bracing Solution Sheet: Across

Manual Method

Please photocopy for each level

Project Name <input style="width: 250px;" type="text"/>							Storey Level <input style="width: 100px;" type="text"/>			
Across (Single, Upper, Lower or Sub-Floor)										
Wall Bracing Line							Wind		Earthquake	
1	2	3	4	5	6	7	W8	W9	E8	E9
Line Label	Bracing Element No.	Supplier	System Number	Element Length	Stud Height	Wall Angle	Rating BU/m	Achieved BUs	Rating BU/m	Achieved BUs
M										
		Minimum BUs Required for Line =				Line Sub-Total =				
N										
		Minimum BUs Required for Line =				Line Sub-Total =				
O										
		Minimum BUs Required for Line =				Line Sub-Total =				
P										
		Minimum BUs Required for Line =				Line Sub-Total =				
Q										
		Minimum BUs Required for Line =				Line Sub-Total =				
R										
		Minimum BUs Required for Line =				Line Sub-Total =				
S										
		Minimum BUs Required for Line =				Line Sub-Total =				
							Wind		Earthquake	
							Across BUs Achieved =		Across BUs Achieved =	
							OK?		OK?	
							From Sheet Two Across BUs Required =		From Sheet Two Across BUs Required =	



Wall & Ceiling Construction Details

Wall Framing

Framing is to comply to NZS 3604:2011 and must be a minimum of 70 x 45mm for internal walls and 90 x 35mm for external walls. Nogs or dwangs are not a requirement in order to achieve the bracing ratings published in this document.

Fastening Bracing Elements to Floors

Quick-Brace™ System Number	Bottom Plate Fixing Requirements			Additional Requirements
	Concrete Floors		Timber Floors	Concrete or Timber
	External Walls	Internal Walls	External or Internal Walls	External or Internal
ES-N	Fix as per NZS 3604:2011	Fix as per NZS 3604:2011. Alternatively see Note 1 below		None
ESSN	Not applicable			
ESSH	Not applicable	Fix as per NZS 3604:2011	Pairs of 100 x 3.75mm hand driven flat head nails or three 90 x 3.15mm power driven nails at 600mm centres all in accordance to NZS 3604:2011	Panel End Hold downs at each end of the bracing element.
EMSH				
ES-H	Fix as per NZS 3604:2011			
EM-H				
ESPH				
EMPH				

Note 1:

Min 75 x 3.8mm shot-fired fasteners with 16mm discs at 150mm & 300mm from end studs and thereafter at 600mm centres. Ensure a minimum penetration of 30mm into the concrete foundation.

Top Plate Connections

Top plate connections detailed on the right meet the requirements of NZS 3604:2011 clause 8.7.3 Joints in Plates. The joints must be over a stud or solid blocking.

A 6kN connection is required if any bracing element in the wall exceeds 100 bracing units. Otherwise a 3kN connection is adequate.

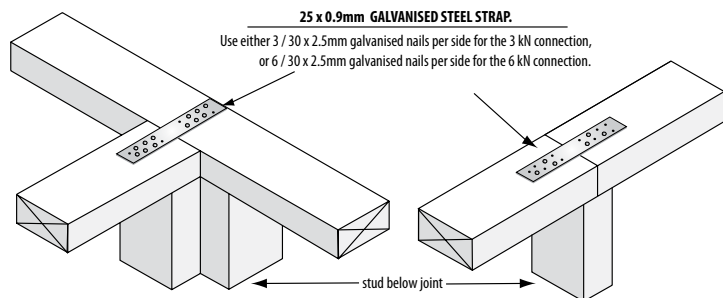

Panel End Hold down Details - Bracing Anchor Brackets

Either Pryda® Bracing Anchor or any other proprietary panel end hold down bracket with a minimum performance of 15kN.

Concrete Floors		Timber Floors	
M12 galvanised anchor bolt or proprietary equivalent with minimum characteristic strength of 15kN . Set no less than 75mm into the concrete.		M12 x 150mm galvanised coach screw or proprietary equivalent with minimum characteristic strength of 12kN.	
External	Internal	External	Internal
Locate the bracket flush with the inside face of the framing in order to maximise concrete edge distance.	Locate the bracket centrally on the bottom plate.	Locate the bracing anchor bracket so that the coach screw is centred over the timber below.	Full depth solid blocking centrally positioned beneath the coach screw.

Panel End Hold down Details - Bracing Strap & Bolt Detail

N.B. Bottom plate anchor placements have been reduced to 80mm from the end of the bracing element. This is to be consistent with the bolt location when using bracing anchor brackets and represents industry best practise. This does not affect previous designs or installations.

Bracing Strap:

400 x 25 x 0.9mm galvanised strap passing under the bottom plate. Six 30 x 2.5mm galvanised flat head nails to each side of the stud and three 30 x 2.5mm galvanised flat head nails to each side of the bottom plate.

The bracing strap should be checked into the framing in order to make the substrate flush when receiving the plasterboard lining. Position it in such a way that the important corner fastenings of the bracing element are not affected by it. Keeping the strap to the edge of the end stud as shown below will ensure the important corner fastenings won't penetrate the bracing strap.

Extra thickness and/or corrosion protection may be required on exposed and unexposed sites as per requirements of NZS 3604:2011

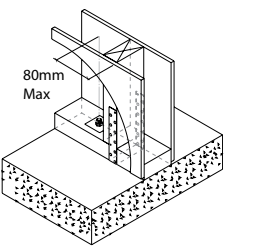
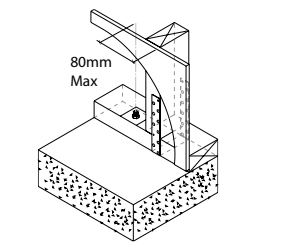
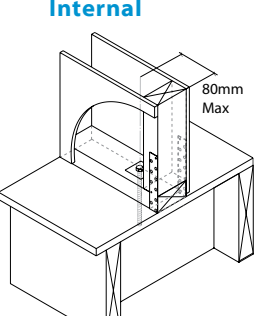
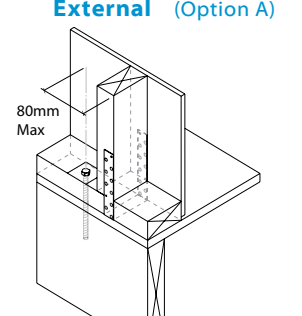
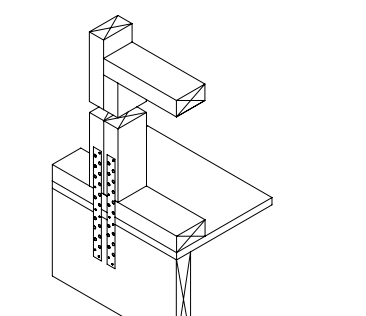
<p>Concrete Floors</p> <p>M12 x 150mm galvanised bolt or proprietary equivalent with minimum characteristic strength of 15kN. Set no less than 75mm into the concrete.</p> <p>Allow for a 3 x 50 x 50mm galvanised washer within 105mm of the ends of the bracing element.</p>	<p>Internal</p> 	<p>External</p> 	<p>Timber Floor: External</p> <p>(Option B)</p> <p>Block up to the first nog to allow for double strapping using three 100 x 3.75mm nails. Two 300 x 25 x 0.9mm galvanised straps pass down onto the floor joist. Six 30 x 2.5mm galvanised flat head nails to each stud and the floor joist and three to the bottom plate.</p>
<p>Timber Floors</p> <p>M12 x 150mm galvanised coach screw or proprietary equivalent with minimum characteristic strength of 12kN.</p> <p>Allow for a 3 x 50 x 50mm galvanised washer within 105mm of the ends of the bracing element.</p>	<p>Internal</p> 	<p>External (Option A)</p> 	<p>External (Option B)</p> 

Intersecting Walls

Provided the minimum wall lengths are complied with and walls are constructed as described in this manual, bracing elements may be interrupted by intersecting walls as detailed below. Fasteners layout at the corners and around the perimeter of the bracing elements are as per The Fastener Layout figures on page 22. Joints between sheets shall be paper taped and stopped in accordance with the Elephant Plasterboard Installation Guide. Panel end hold-downs must also comply except that the location of bottom plate anchors is modified for L and T intersections as defined below.

The minimum bracing element length is 900mm for single sided bracing systems (ES-N, ES-H and EM-H) and 600mm for double sided bracing systems, (ESSN, ESSH, ESPH, EMSH and EMPH.)

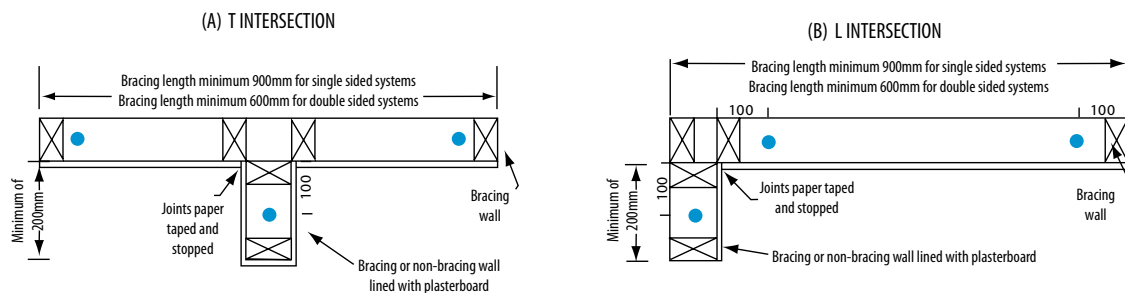

● Bottom plate fixing as required for bracing element or NZS 3604:2011 (as appropriate)

Parapets, Gable End Walls or Dropped or Suspended Ceilings

Sheeting material used in bracing elements must connect to both the top and bottom plates. Where the top plate is not accessible, fixing to a row of nogs is not an acceptable solution. Detail below are two possible solutions.

A continuous length of timber or ribbon plate, with the same minimum size as the bottom plate, fixed across the face of the studs just above the row of nogs and at the ceiling line.

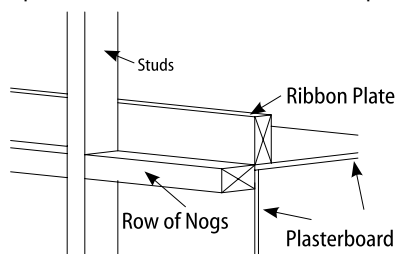

A metal angle of minimum of 50 x 50 x 0.55mm fixed to the row of nogs at the ceiling line. Use minimum 30 x 2.5mm FH galv nails at 300mm centres.

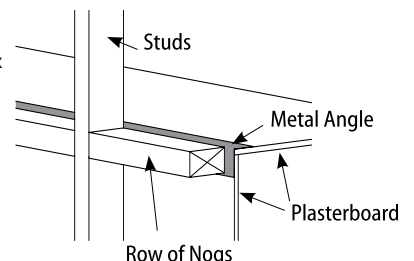

Ceiling Diaphragms

Ceiling diaphragms are required to comply with Section 5.6 and 13.5 of NZS 3604:2011. Ceiling diaphragms are required when distances between bracing lines exceed 6m (when Dragon ties not used) or 7.5m if Dragon ties are used as per figure 8.1 in NZS 3604:2011.

Ceiling diaphragms shall not exceed 12m in length and the length shall not exceed twice the width (both length and width being measured between supporting walls). The ceiling lining shall cover the entire area of the ceiling diaphragm.

Limitations for Ceiling Diaphragm Systems

Ceiling diaphragm requirements are dependent on the length of the room and/or the roof pitch.

- C1:** Not steeper than 15 degrees and not longer than 7.5m
- C2:** Not steeper than 25 degrees and not longer than 12m or Not steeper than 45 degrees and not longer than 7.5m

Plasterboard Lining Requirement:

Minimum 10mm Elephant Standard-Plus Plasterboard

Framing Members:

Ceiling battens shall be spaced at maximum;

- 600mm centres for 10mm Elephant Standard-Plus or 13mm Elephant Standard-Plus Plasterboard.

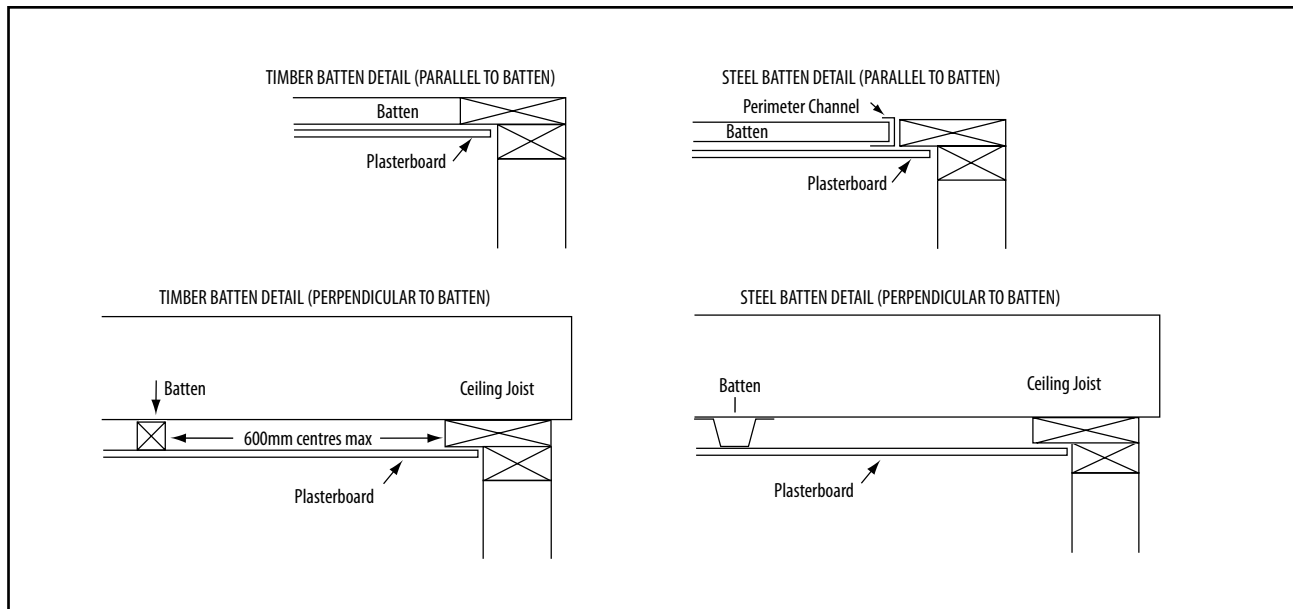
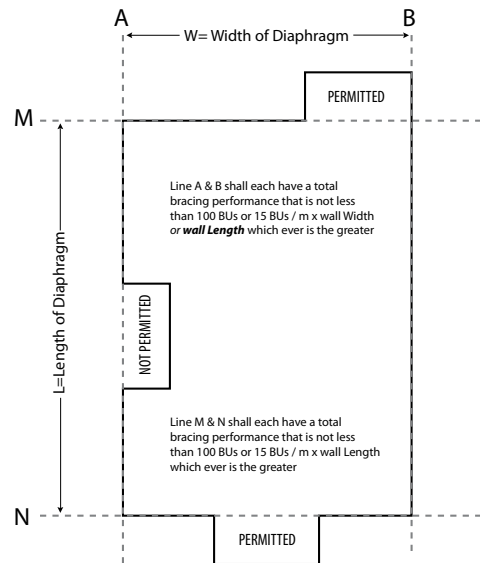

Timber or Steel Battens

Timber battens: Must be fixed according to NZS 3604:2011.

Steel battens: Minimum 0.55 BMT thickness with flanges not less than 8mm in order to allow the direct screwing, using 2/32mm x 8g wafer head self tapping screws, to the ceiling framing members. If a clip system is used then a solid timber block or continuous timber member must be fixed to the framing member.

A steel perimeter channel or metal angle is required to receive the ends of the steel battens.

The linings must be fastened to solid continuous timber member at the perimeter of the ceiling diaphragms. This is achieved with either at 140mm double top plate or by fixing continuous timber member to the original top plate using fixing requirements for built up members and nailed together according to NZS 3604:2011 clause 2.4.4.7

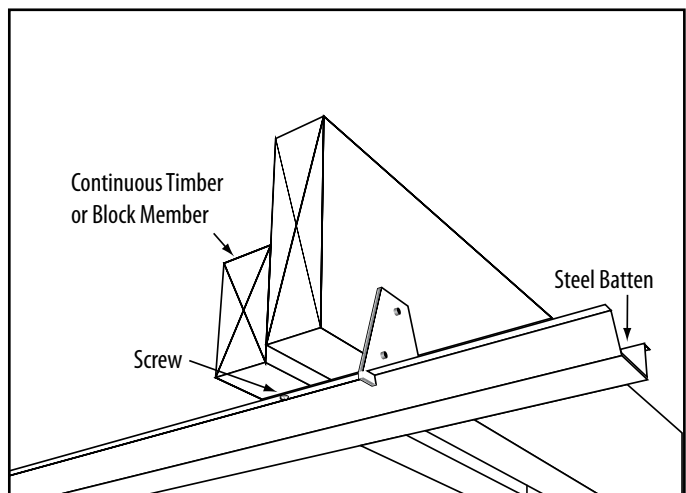

Ceiling Diaphragms continued ...

Coved Ceilings

Ceilings diaphragms with more than one gradient are allowable, by using metal folded angles with a minimum gauge of 0.55 BMT at the junctions.

Use 32mm x 6g course thread drywall screws when fixing to timber battens and use 32mm x 8g drywall self tapping screws or similar when fixing to metal battens.

The plasterboard is fixed to these folded metal angles at 75mm or 100mm or 150mm centres depending on conditions detailed below.

Use 25mm x 6g drywall self tapping screws.

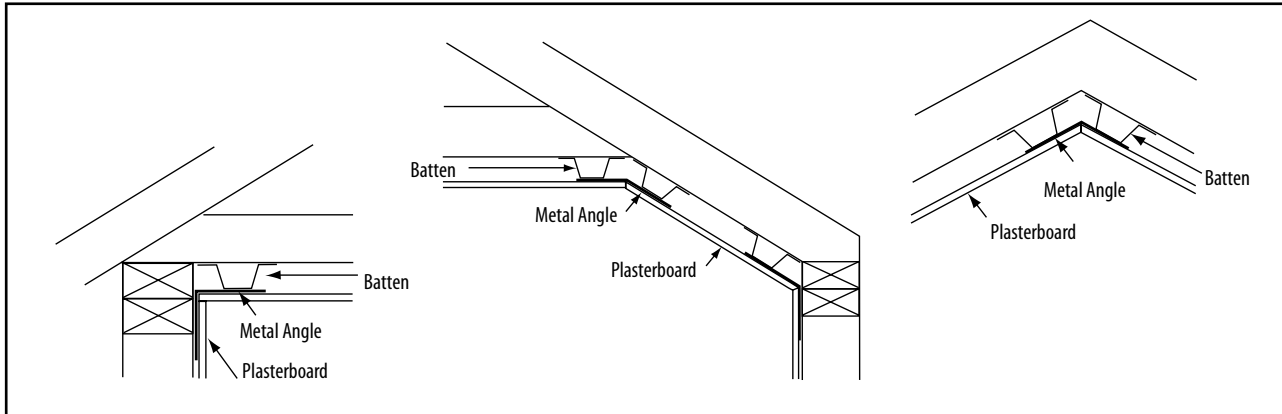

Minimum sheet size requirements:

Minimum sheet size shall be 900mm wide by 1800mm long where possible except where building dimensions prevent their use.

Sheets between 600mm wide and 900mm wide by between 1200mm long and 1800mm long can be used provided they are back blocked with adjacent sheets.

Openings in Ceiling Diaphragms:

Openings are allowable and must be within the middle third of the diaphragms length and width and no opening dimension shall be greater than the ceiling diaphragm width. Fix sheets at 150mm centres minimum to opening trimmers. Refer to **Openings in Bracing Elements** on page 22.

Fasteners:

Timber battens & Timber perimeters: 32mm x 6g High thread Drywall screws

Steel battens and Steel perimeter: 25mm x 6g Self Tapping Drywall screws

Fastener Brands Allowable

Fortress®, Grabber® or Senco®.

(Other fastener brands need to demonstrate equal or better performance).

Fastening Centres:

The corner pattern fastening centres are as follows;

For ceiling diaphragms not steeper than 15 degrees and not longer than 7.5m

Place fasteners 50mm, 50mm, 50mm, 75mm, 75mm from all corners of the diaphragm.

Then place fasteners at maximum 150mm centres to the boundary members and around the perimeter of the diaphragm as per ceiling diaphragm pattern **C1** on the right.

For ceiling diaphragms that are:

either not steeper than 25 degrees and not longer than 12.0m

or not steeper than 45 degrees and not longer than 7.5m

Place fasteners 50mm, 50mm, 50mm, 75mm, 75mm from all corners of the diaphragm.

Then place fasteners at maximum 100mm centres to the boundary members and around the perimeter of the diaphragm as per ceiling diaphragm pattern **C2** on the right.

Fix all fasteners at no less than 12mm from paper bound sheet edges and 18mm from sheet ends or cut edges.

Fastening requirements within the ceiling diaphragm are conventional. All in accordance with the Elephant Plasterboard Installation Guide.

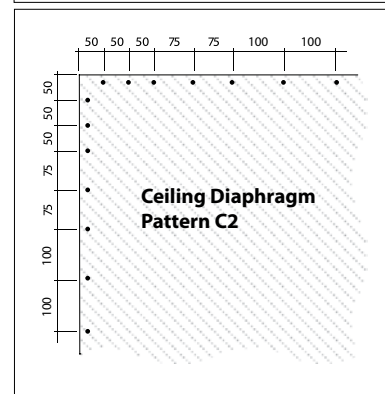
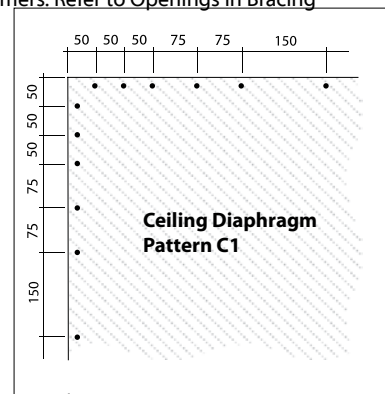

Jointing:

All joints shall be paper tape reinforced and stopped. Sheet end butt joints should be between the battens and back blocked.

All in accordance with the Elephant Plasterboard Installation Guide.



Wall Bracing Construction Details

Fastening the Plasterboard Linings

Elephant Plasterboard designated as a bracing element must be constructed with specified fasteners and fastener patterns. Specialised panel end hold downs may also be required as they are essential for obtaining the bracing unit ratings. The corner detail for plasterboard bracing elements require specific increased fastening. See figures below.

Fasteners:

Timber battens & Timber perimeters: 32mm x 6g High thread Drywall screws

Steel battens and Steel perimeter: 25mm x 6g self tapping screws

Fastener Brands Allowable

Fortress®, Grabber® or Senco®. (Other fastener brands need to demonstrate equal or better performance).

Fastener Layout

Refer Condensed Bracing Corner Pattern on the right. Place all fasteners 12mm from paper bound sheet edges and 18mm from sheet ends or cut edges. Fastening the middle of the bracing element is as per the recommended screw and glue methods. Refer to Elephant Plasterboard Installation Guide.

Minimum Sheet Size

Sheets less than 300mm wide are allowable provided that the joints form over solid framing or the sheet is back blocked. All joints must be paper taped and stopped.

Butt Joints

All butt joints should be either fitted over nogs or studs and fastened at 200mm centres or back-blocked. All joints must be paper taped and stopped. Refer to Elephant Plasterboard Installation Guide.

Horizontal Fixing

QuickBrace™ systems may be fixed horizontally. The specialised corner and perimeter bracing pattern need only to be placed over the length and width of the bracing element. Fastening in the field of the bracing element is as per the recommended glue and screw method. Note- Care should be taken during the installation of the plasterboard, as often the studs that require the special mechanical fixing pattern are in the field of the sheet. It is important to insure that the adhesives are not placed on or near the studs that require these special perimeter fasteners as this can be a cause of screw popping.

Alternative Corner Fastener Layout

If the installer has used the 50, 50, 50, 75, 75, 150 corner screw pattern then this can easily be remedied by simply placing an extra screw between the first 150mm (where possible).

Refer to the Alternative Condensed Bracing Corner Pattern on the right.

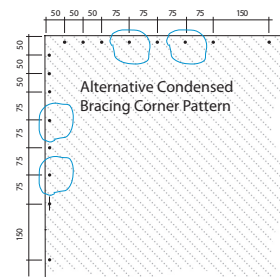
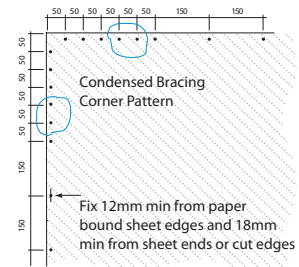

Wet Areas

Do not place bracing elements in areas such as behind showers and baths. Placing bracing elements in water splash areas is acceptable provided that these areas are maintained impervious for the life of the building. Bracing elements require a 50 year durability.

Allowable Substitutions

Elephant Aquaboard can be substituted for the Elephant Standard-Plus in QuickBrace™ systems ES-N, ESSN, ES-H, ESSH, ESPH and EMSH. Elephant Aquaboard can be substituted for the Elephant Multiboard in Quick-Brace™ systems EM-H, EMSH and EMPH provided that the element is 600mm or longer and the perimeter screw pattern is reduced to 100mm centres. Ensure that all other relevant bracing system requirements including the important corner patterns are met.

Openings in Bracing Elements

Large openings can only be placed in the middle 1/3 of the bracing element. Neither the opening height nor length can be more than 1/3 of the bracing element height. Fix the wall linings around the opening trimmers at 150mm centres. Smaller openings of 90 x 90mm or less are allowable but cannot be placed closer than 90mm from the edge of the bracing element.

Plywood

For systems ESPH and EMPH plywood is required. This can be Grade D-D 7mm construction plywood at a minimum. The plywood must be manufactured as per Australian/New Zealand Standard AS/NZS 2269:2004. The nailing pattern is at 150mm centres around the perimeter of the bracing element or each plywood sheet, whichever is the lesser width, using 50 x 2.8mm Flat head galvanised or stainless steel nails.

Sheet edges must be supported by framing or blocking. The corner pattern fastening is conventional and there is no need for the specialised corner patterns as is required on the plasterboard side of the brace.

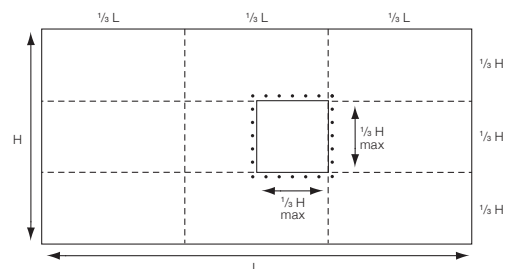
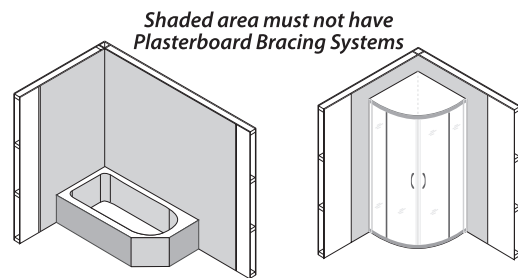

PLASTERBOARD ON ONE SIDE

System Number	Lining Requirement	Min Length (m)	BU/m		Panel Hold-downs	Bracing Corner Pattern
			Wind	Earth-quake		
ES-N	Elephant Standard-Plus on one side	0.4	65	60	No	
		1.2	70	65		
		1.8	80	65		
ES-H	Elephant Standard-Plus on one side	0.4	80	75	Yes	
		0.8	100	85		
		1.8	115	85		
EM-H	Elephant Multiboard on one side	0.4	95	100		Yes
		0.8	120	110		
		1.2	140	115		

FRAMING

Framing heights and dimensions to comply with NZS 3604:2011 and must be a minimum of 70 x 45mm for internal walls and 90 x 35mm for external walls. Nogs and Dwargs are not a requirement in order to achieve the bracing ratings in this document.

Refer to relevant sections and clauses of

NZBC B1: Structure; AS1 Clause 3 Timber -NZS 3604

NZBC B2: Durability; AS1 Clause 3.2 Timber -NZS 3602

FASTENING BRACING ELEMENTS TO FLOOR

Timber Floor:

Fastening within the bracing element must be done in accordance with NZS 3604:2011.

i.e. Either pairs of 100 x 3.75mm hand driven nails or three 90 x 3.15mm power driven nails at 600mm centres.

For **ES-H** and **EM-H**: Use the panel hold downs at each end of the bracing element.

Concrete Floors:

External or Internal walls: Within the bracing element fix the bottom plate as per NZS 3604:2011.

For **ES-N**: On Internal Walls alternatively use 75 x 3.8mm shot-fired fasteners with 16mm discs at 150mm & 300mm from end studs and thereafter at 600mm centres. Ensure a minimum penetration of 30mm into the concrete foundation.

For **ES-H** and **EM-H**: Use the panel hold downs at each end of the bracing element.

WALL LINING (As per Specified System Above)

One layer of Plasterboard lining type as per specified system above to ONE side of frame.

The Plasterboard sheets can be fixed vertically or horizontally. Use full height or full length sheets when fixing vertically or horizontally where possible. All sheet end butt joints must be fixed over solid timber framing and fastened at 200mm centres. Alternatively the sheet end butt joints may be back blocked. Sheets shall be touch fitted.

FIXING OF PLASTERBOARD LININGS

Fastening: (Corners and Perimeters of the bracing element)

32mm x 6g High thread Drywall screws (Fortress® or Grabber® or Senco®)

Fastening Centres: (Corners and Perimeters of the bracing element)

Corner Pattern: Refer to the bracing corner pattern above.

(See Page 22 for alternative allowable corner pattern.)

Perimeter Pattern: Place fasteners at 150mm centres around perimeter of bracing element.

Place all fasteners 12mm from paper bound sheet edges and 18mm from sheet ends or cut edges.

Fasteners and Fastening Centres in the Field of the bracing element

For vertically fixed sheets place fasteners at 300mm centres to the intermediate sheet joints. For Horizontally fixed sheets place fasteners at the sheet edge that crosses the studs. Place daubs of Drywall adhesives at 300mm centres to intermediate studs. Take extra care to ensure that screws or clouts are not placed closer than 200mm from any daubs of adhesive.

JOINTING

All fasteners stopped and all sheet joints reinforced with paper jointing tape.

All in accordance with the Elephant Plasterboard Installation Guide.

Horizontal Fixing

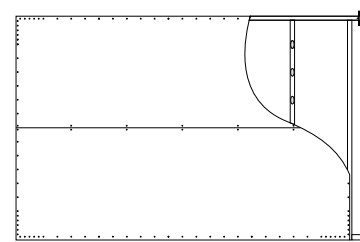

Vertical Fixing

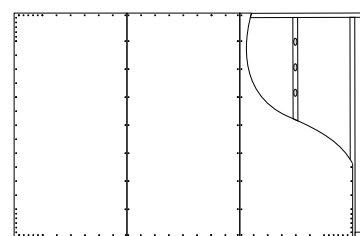

PLASTERBOARD ON BOTH SIDES

System Number	Lining Requirement	Min Length (m)	BU/m		Panel Hold-downs	Bracing Corner Pattern
			Wind	Earth-quake		
ESSN	Elephant Standard-Plus on Both sides	0.4	80	75	No	
		0.8	90	80		
		1.2	95	85		
ESSH	Elephant Standard-Plus on Both sides	0.4	95	110	Yes	
		0.8	140	130		
		1.2	150	140		
EMSH	Elephant Multiboard on one side, Elephant Standard plus on the other	0.4	110	115		Yes
		0.8	140	135		
		1.2	150	145		

FRAMING

Framing heights and dimensions to comply with NZS 3604:2011 and must be a minimum of 70 x 45mm for internal walls and 90 x 35mm for external walls. Nogs and Dwargs are not a requirement in order to achieve the bracing ratings in this document.

Refer to relevant sections and clauses of

NZBC B1: Structure; AS1 Clause 3 Timber -NZS 3604

NZBC B2: Durability; AS1 Clause 3.2 Timber -NZS 3602

FASTENING BRACING ELEMENTS TO FLOOR

Timber Floor:

Fastening within the bracing element must be done in accordance with NZS 3604:2011.

i.e. Either pairs of 100 x 3.75mm hand driven nails Or three 90 x 3.15mm power driven nails at 600mm centres.

For **ESSH** and **EMSH**: Use the panel hold downs at each end of the bracing element.

Concrete Floors:

Within the bracing element fix the bottom plate as per NZS 3604:2011.

For **ESSN**: For Internal Walls alternatively use 75 x 3.8mm shot-fired fasteners with 16mm discs at 150mm & 300mm from end studs and thereafter at 600mm centres. Ensure a minimum penetration of 30mm into the concrete foundation.

For **ESSH** and **EMSH**: Use the panel hold downs at each end of the bracing element.

WALL LINING (As per Specified System Above)

One layer of Plasterboard lining type as per specified system above to BOTH sides of frame. The Plasterboard sheets can be fixed vertically or horizontally. Use full height or full length sheets when fixing vertically or horizontally where possible. All sheet end butt joints must be fixed over solid timber framing and fastened at 200mm centres. Alternatively the sheet end butt joints may be back blocked. Sheets shall be touch fitted.

FIXING OF PLASTERBOARD LININGS

Fastening: (Corners and Perimeters of the bracing element)

32mm x 6g High thread Drywall screws (Fortress® or Grabber® or Senco®)

Fastening Centres: (Corners and Perimeters of the bracing element)

Corner Pattern: Refer to the bracing corner pattern above.

(See Page 22 for alternative allowable corner pattern).

Perimeter Pattern: Place fasteners at 150mm centres around perimeter of bracing element.

Place all fasteners 12mm from paper bound sheet edges and 18mm from sheet ends or cut edges.

Fasteners and Fastening Centres in the Field of the bracing element

For vertically fixed sheets place fasteners at 300mm centres to the intermediate sheet joints.

For Horizontally fixed sheets place fasteners at the sheet edge that crosses the studs. Place daubs of Drywall adhesives at 300mm centres to intermediate studs. Take extra care to ensure that screws or clouts are not placed closer than 200mm from any daubs of adhesive.

JOINTING

All fasteners stopped and all sheet joints reinforced with paper jointing tape.

All in accordance with the Elephant Plasterboard Installation Guide.

Horizontal Fixing

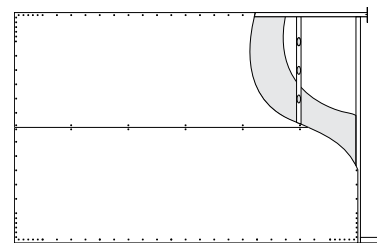

Vertical Fixing

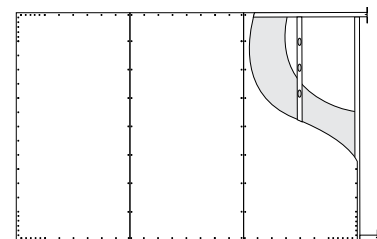

PLASTERBOARD ON ONE SIDE, PLYWOOD THE OTHER

System Number	Lining Requirement	Min Length (m)	BU/m		Panel Hold-downs	Bracing Corner Pattern
			Wind	Earth-quake		
ESPH	Elephant Standard-Plus on One Side Plywood on the Other Side	0.4	100	115	Yes	
		0.8	140	140		
		1.2	150	150		
EMPH	Elephant Multiboard on One Side Plywood on the Other Side	0.4	120	135		
		0.8	140	145		
		1.2	150	150		

FRAMING

Framing heights and dimensions to comply with NZS 3604:2011 and must be a minimum of 70 x 45mm for internal walls and 90 x 35 mm for external walls. Nogs and Dwargs are not a requirement in order to achieve the bracing ratings in this document.

Refer to relevant sections and clauses of

NZBC B1: Structure; AS1 Clause 3 Timber -NZS 3604

NZBC B2: Durability; AS1 Clause 3.2 Timber -NZS 3602

FASTENING BRACING ELEMENTS TO FLOOR

Timber Floor:

Fastening within the bracing element must be done in accordance with NZS 3604:2011.

i.e. Either pairs of 100 x 3.75mm hand driven nails or three 90 x 3.15 power driven nails at 600mm centres.

For **ESPH** and **EMPH**: Use the panel hold downs at each end of the bracing element.

Concrete Floors:

Within the bracing element fix the bottom plate as per NZS 3604:2011.

For **ESPH** and **EMPH**: Use the panel hold downs at each end of the bracing element

WALL LINING (As per Specified System Above)

One layer of Plasterboard lining type as per specified system above to ONE side of frame.

One layer of 7mm D-D Plywood as per specified system above to OTHER side of frame.

The Plasterboard sheets can be fixed vertically or horizontally. Use full height or full length sheets when fixing vertically or horizontally where possible. All sheet end butt joints must be fixed over solid timber framing and fastened at 200mm centres.

Alternatively the sheet end butt joints may be back blocked.

Plywood sheets must be fixed vertically with edges supported by framing or blocking. Sheets shall be touch fitted.

FIXING OF PLASTERBOARD LININGS

Fasteners: (Corners and Perimeters of the bracing element)

32mm x 6g High thread Drywall screws (Fortress® or Grabber® or Senco®)

Fastening Centres: (Corners and Perimeters of the bracing element)

Corner Pattern: Refer to the bracing corner pattern above.

(See Page 22 for alternative allowable corner pattern).

Perimeter Pattern: Place fasteners at 150mm centres around perimeter of bracing element.

Place all fasteners 12mm from paper bound sheet edges and 18mm from sheet ends or cut edges.

Fasteners and Fastening Centres in the Field of the bracing element

For vertically fixed sheets place fasteners at 300mm centres to the intermediate sheet joints. For horizontally fixed sheets place fasteners at the sheet edge that crosses the studs. Place daubs of Drywall adhesives at 300mm centres to intermediate studs. Take extra care to ensure that screws or clouts are not placed closer than 200mm from any daubs of adhesive.

FIXING OF PLYWOOD LININGS

Fasteners: (Corners and Perimeters of the bracing element)

50 x 2.8mm Flat head Galvanized or Stainless Steel Nails.

Fix at 150mm centres around perimeter of the bracing element and the perimeter of each sheet.

Fix at 300mm centres to intermediate studs that are not at the end of a bracing element.

The corner pattern fastening is conventional and there is no need for the specialized corner pattern as is required on the plasterboard side of the brace.

JOINTING

All fasteners stopped and all sheet joints reinforced with paper jointing tape.

All in accordance with the Elephant Plasterboard Installation Guide.

Horizontal Fixing

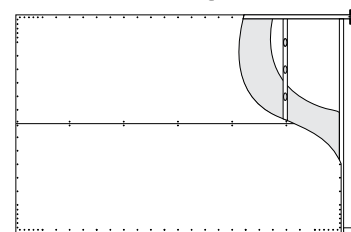

Plasterboard side shown

Vertical Fixing

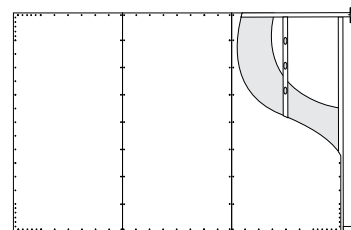

Notes:



Product Range

TE/TE = Tapered Both Edges

TE/SE = Tapered One Edge, Square the Other

Product Weights and available Lengths

PRODUCT	THICK-NESS	EDGE TYPE	WIDTH	WEIGHT	LENGTH									
					mm	mm	Kg per m ²	2.4m	2.7m	3.0m	3.3m	3.6m	4.2m	4.8m
Standard-Plus	10	TE/TE	1200	7.4	✓	✓	✓	✓	✓	✓	✓	✓	✓	✓
Standard-Plus	13	TE/TE	1200	9.2	✓	✓	✓	✓	✓	✓	✓	✓	✓	✓
Horizontal Standard-Plus	10	TE/SE	1200	7.4	✓		✓		✓	✓	✓	✓	✓	✓
Wide Horizontal Standard-Plus	10	TE/SE	1350	7.4					✓		✓	✓	✓	✓
Multiboard	10	TE/TE	1200	9.0	✓	✓	✓		✓					
Multiboard	13	TE/TE	1200	12.0	✓	✓	✓		✓					
Multiboard	16	TE/TE	1200	13.8	✓	✓	✓							
Aquaboard	10	TE/TE	1200	8.5	✓	✓	✓		✓					
Aquaboard	13	TE/TE	1200	11.5	✓	✓	✓		✓					

Product Primary Functions

PRODUCT	THICK-NESS	EDGE TYPE	WIDTH	Primary Functions								
				mm	mm	Superior Finish	Horizontal Fixing	Span 600* Centres on Ceilings	Bracing	Fire Resistant	Noise Control	Impact Resistant
Standard-Plus	10	TE/TE	1200	•		•	•	•				
Standard-Plus	13	TE/TE	1200	•		•	•	•				
Horizontal Standard-Plus	10	TE/SE	1200	•	•		•	•				
Wide Horizontal Standard-Plus	10	TE/SE	1350	•	•		•	•				
Multiboard	10	TE/TE	1200	•		•	•	•	•			
Multiboard	13	TE/TE	1200	•		•	•	•	•	•		
Multiboard	16	TE/TE	1200	•		•	•	•	•	•		
Aquaboard	10	TE/TE	1200	•			•	•	•			•
Aquaboard	13	TE/TE	1200	•		•	•	•	•	•	•	•

* In areas with significant temperature or humidity variations e.g. bathrooms, it is recommended to place battens at max 450mm centres when using 10mm Standard-Plus or 10mm Aquaboard



Elephant Plasterboard QuickBrace Systems Manual

July 2015

Elephant Plasterboard (NZ) Limited

FOR MORE INFORMATION VISIT

www.elephantplasterboard.co.nz

email info@elephantpb.co.nz

call 0800 ELEPHANT (353 742)



Elephant
Plasterboard

STRENGTH WITH STYLE